

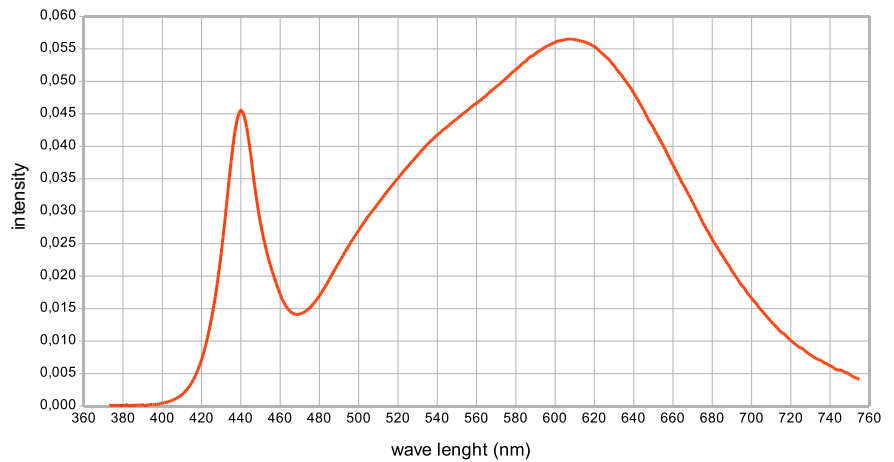

Spectral characteristics of the emitted light (MultiWhite LED diodes)



Product description

PxArt 12 is a professional LED lamp designed to illuminate museum exhibitions or other exhibitions.

Using the latest solid-state LED light source and advanced control electronics this high-class illuminator meets very high requirements for museum lighting. Its main advantages are: a complete lack of ultraviolet radiation, trace amounts of infrared radiation, very high color rendering index (CRI), adjustable color temperature of the emitted light, high brightness and low energy consumption.

The device has built-in an adapter that allows to assembly onto the GLOBALtrac Control busbar equipped with an additional three control lines. Individual two addresses assigned to each lamp allow to adjust settings, the brightness and color temperature, independently for other products.

Using buttons located on the lamp housing you can also control it manually (e.g. when the PX261 is connected to the busbar without the control line).

The lamp uses high-performance Osram Oslon LEDs and efficient control system so that the lamp produces as little heat as it is possible.

Lamp housing allows you to change the setup position of light in two axes.

Technical data

catalog number	Px261
power supply:	230 V AC
number of LEDs:	12
power consumption:	20 W
max. temperature rise housing:	+ 30° C
luminous flux:	1200 lumens
LEDs lifespan:	50 000 h
beam angles of lenses:	10°, 20°, 30°, 40°
color temperature adjustment range:	2700-5000 K
range of brightness adjustment:	0-100%
color rendering index CRI:	min. 90
control protocol:	DMX-512 / RDM
available housing colors:	white, black or silver
weight:	2,2 kg
dimensions:	width: 159 mm height: 230 mm reflector diameter: 121.5 mm

Manual control buttons and socket for programming parameters of the lamp

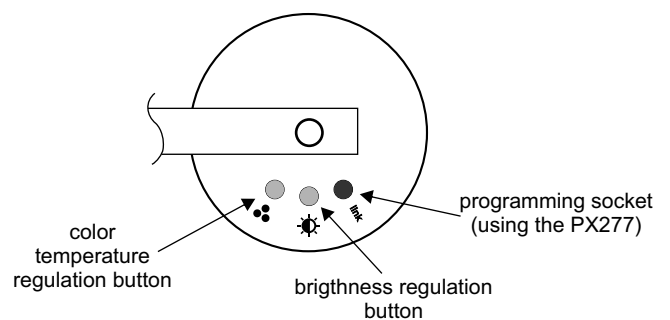

programmable scenes:	1
number of control channels:	2 (brightness and color temperature)
mounting:	GLOBALtrac Control bus-bar
manual control:	YES
DMX-512 signal indicator:	YES
individual channels addressing feature:	YES

On request the RGB lamp version is also available.

Dimensions - technical drawing

Connection scheme

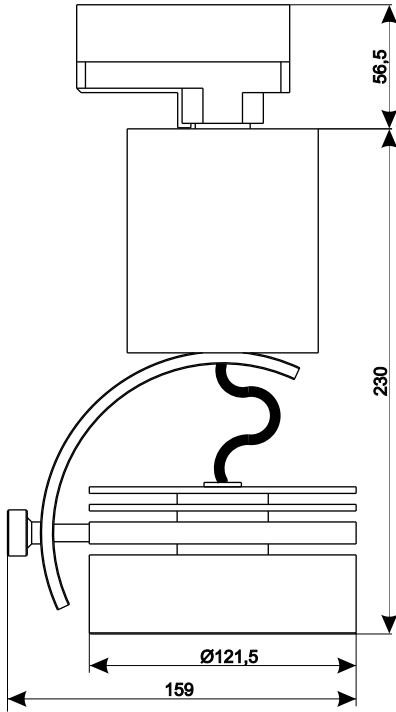

Dimensions in millimeters

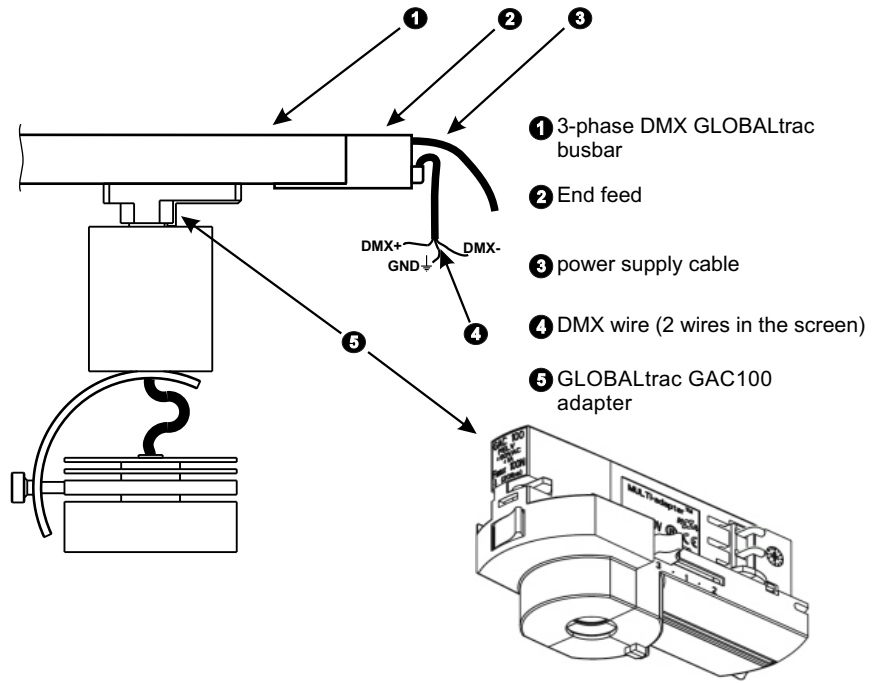

Distribution of luminous flux

Distribution of light - a side view

Beam angle

