

PY517

Receiver 4ch P

GORKE (RSU-K04/H2)

User manual



Table of Contents

1 Description.....	3
2 Safety conditions.....	4
3 Connectors and control elements.....	5
4 Adding transmitter to memory.....	6
5 Modes of operation.....	7
5.1 Changing channel mode.....	9
6 Setting the activation time in monostable mode.....	10
7 Deleting the stored keys.....	11
8 Connection scheme.....	12
9 Technical data.....	15

Manufacturer reserves the right to make modifications in order to improve device operation.

PXM Marek Źupnik sp.k.
Podłęże 654
32-003 Podłęże
BDO register number 000005972

tel. +48 12 385 83 06
mail: info@pxm.pl
www.pxm.pl

Rev.1-0
01.12.2020

1 Description

PY517 is a 4-channel radio receiver designed for installation in closed rooms. The receiver uses the H2 heterodyne receiver module, which guarantees twice the range than its basic version (PY511 – RSU-K04). Each channel, which works as a relay, can work in one of four modes. To work properly with PXM devices each channel should be set to monostable or momentary mode.

Receiver 4ch P works with transmitters from the sA series. The working range depends on the type of transmitter and can be from 200 to 1000 meters. The transmission is coded and is based on a variable code, which ensures high security when using wireless systems. Each transmitter has an individual code, and the receiver only reacts to signals that are received from the transmitters stored in its memory (up to 40 buttons).

The receiver is powered by 12V DC safe voltage, and its plastic housing has been designed in such a way that it can be mounted on the wall.

2 Safety conditions

PY517 is a device powered with safe voltage 12V DC; however, during its installation and use the following rules must be strictly observed:

1. The device may only be connected to 12V DC with current-carrying capacity compatible with technical data.
2. All the conductors should be protected against mechanical and thermal damage.
3. In the event of damaging any conductor, it should be replaced with a conductor of the same technical data.
4. All repairs and wiring connections may only be carried out with the power supply disconnected.
5. PY517 should be strictly protected against contact with water and other liquids.
6. All sudden shocks, particularly dropping, should be avoided.
7. The device cannot be turned on in places with humidity exceeding $93\pm 3\%$.
8. The device cannot be used in places with temperature lower than -10°C or higher than $+55^{\circ}\text{C}$.
9. Clean with damp duster only.

3 Connectors and control elements

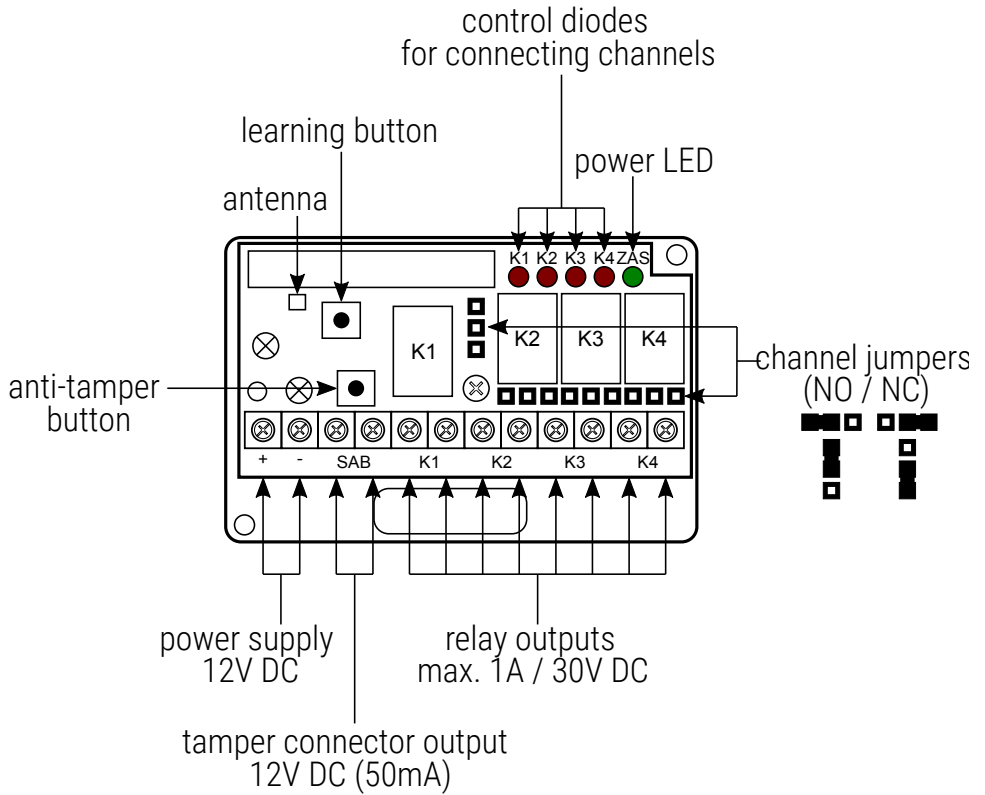

4 Adding transmitter to memory

1. Press and hold the *learning* button for 1 – 3s.

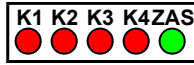

2. All LEDs will light up – release the *learning* button.
3. Select the channel to which the transmitter is to be assigned with the *learning* button.

Channel 1

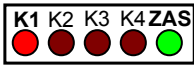

Channel 2

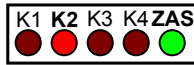

Channel 3

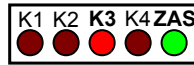

Channel 4

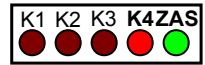

4. After selecting the channel on the receiver, you need to press the key on the transmitter to be responsible for the selected channel.
5. Pressing the button on the transmitter will blink the channel LED to which the selected key will be assigned.
6. Press the same key again to save the selection to the receiver's memory.
7. The receiver will blink all **red** LEDs and turn them off – it means that the procedure of assigning the key to the selected channel was successful.

NOTE! If the receiver does not blink all **red** LEDs, it means that the selected key has not been entered into the receiver's memory, the reason may be:

- the key has already been stored in the receiver's memory
- the waiting time for the signal from the transmitter has been exceeded (~8s)

NOTE! A maximum of 40 keys can be assigned to the receiver. Adding key number 41 will delete the key saved in the memory as 1, etc. One key can be assigned to many channels in the receiver – this allows you to control several channels with one key.

5 Modes of operation

Each channel can work independently in one of four operating modes. In the case of cooperation with PXM controllers, it is recommended to use the monostable or momentary mode.

- **bi-stable** – each time you press the key, the status changes to the opposite
- **monostable** – pressing the key activates the relay for a programmed time in the range of 1 – 255s (for more information see section 6. Setting the activation time in monostable mode)
- **momentary** – the relay remains on all the time when the key in the transmitter is pressed, releasing the key will turn off the relay. For this mode, the function is available consisting in temporarily holding the relay in the switched on state, even if the signal from the transmitter is

interrupted or disturbed. The hold time on the channel is 10% of the time set for the monostable mode on this channel. In order for the relay to operate always for ~1s from the moment the button is released, set the time in monostable mode to ~10s (information on setting the time is available in section 6. Setting the activation time in monostable mode).

- **two-key** – the relay is switched on with the odd-numbered key (1, 3, 5, 7 etc.) assigned to the channel, while it is switched off by the even-numbered key (2, 4, 6, 8 etc.). To use this mode, you must assign two keys to one channel – even and odd. Typing only the odd key will cause that the channel can be turned on, but it will not be possible to turn it off (no even key assigned).

In case if only an even key is assigned to a given channel and the receiver does not respond, it may mean that the channel is set in two-key mode.

5.1 Changing channel mode

To change the operating mode of the selected channel, you need a transmitter with a key stored in the PY517 memory. To do this:

1. Press and hold the *learning* button for 3 – 5s.
2. All the LEDs will start blinking – release the *learning* button.
3. The LEDs will light up permanently.
4. Select the mode with the *learning* button.

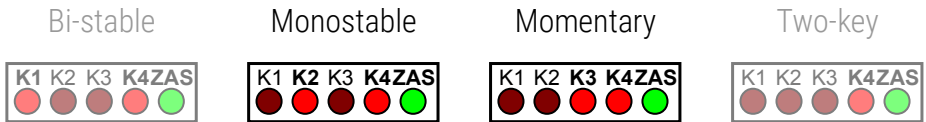

5. After selecting the mode, press the key on the transmitter responsible for the channel in which the selected mode is to be set.
6. Saving the mode change on the selected channel will be confirmed by three blinks of all **red** LEDs.

NOTE! If a key that is assigned to several channels is used, the mode change will be applied to all channels that are assigned to this key.

6 Setting the activation time in monostable mode

In monostable mode, it is possible to program the relay on time in the range of $\sim 1 - 255\text{s}$ ($\sim 4\text{min } 15\text{s}$). To program the time you need a transmitter with a key assigned to the channel in which the change is to take place. To do this:

1. Press and hold the *learning* button for 5 – 8s.
2. All the LEDs will start blinking, and after a while they will start blinking much faster – release the *learning* button.
3. Releasing the *learning* button will cause all **red** LEDs to flash. One blink corresponds to $\sim 1\text{s}$.
4. After the required time has elapsed, press in the transmitter the key corresponding to the channel to which the new relay activation time should be assigned in the monostable mode.
5. Successful saving will be confirmed by blinking of all **red** LEDs three times.
6. Leaving the receiver in the countdown mode will lead to the countdown of 255s, and then all the LEDs will be lit for $\sim 4\text{ min}$ – pressing the key during this time will program the maximum time (255s) to the channel assigned to the key. If no key is pressed before the end of $\sim 4\text{ minutes}$, the receiver will exit the time programming mode without making any changes.

NOTE! If the key has been programmed to several channels, then the relay activation time will be changed in all channels that were assigned to it.

7 Deleting the stored keys

The deletion of all memorized keys has no effect on the operating modes of individual channels and the switching times of relays in monostable mode.

To delete all stored keys:

1. Press and hold the *learning* button for more than 8s.
2. All the LEDs will start blinking, then they will blink significantly faster, when they light up permanently, you can release the *learning* button.
3. All **red** LEDs will turn off.
4. The procedure has been successfully completed, please check the deletion.

NOTE! Deleting deletes all stored keys. If the user wants to delete only one key, then after the deleting process, the ones to be saved must be re-entered. Disconnecting the power supply does not cause any loss of information about the stored keys and receiver operating modes.

8 Connection scheme

Connection PY517 with PX340 / PX345 / PX710 controller to digital inputs
(sink in) – “joint plus”

power supply
12V DC

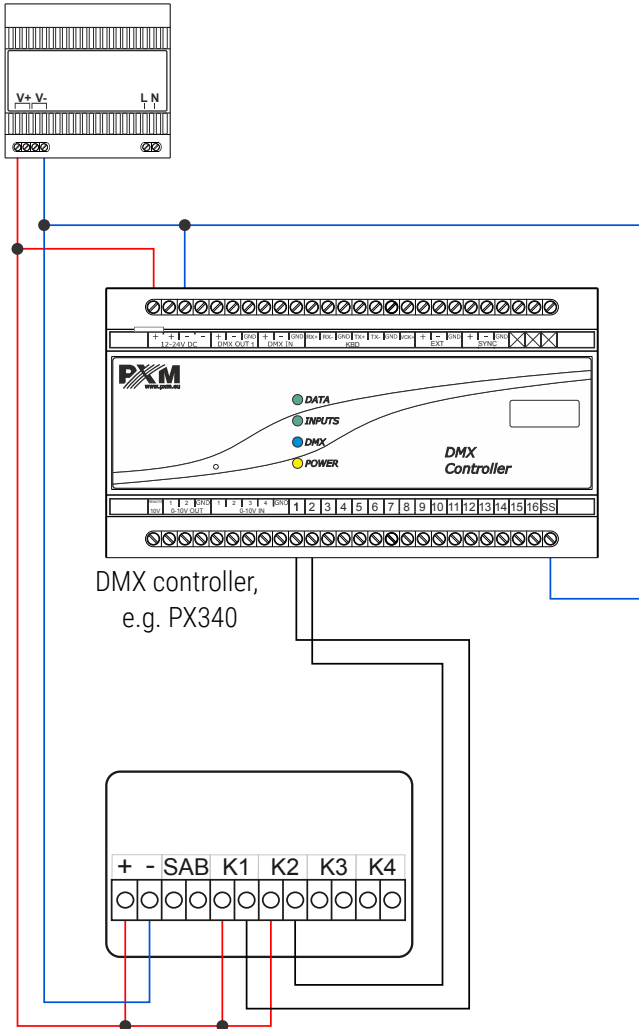

Connection PY517 with PX340 / PX345 / PX710 controller to digital inputs
(source in) – “joint mass”
power supply
12V DC

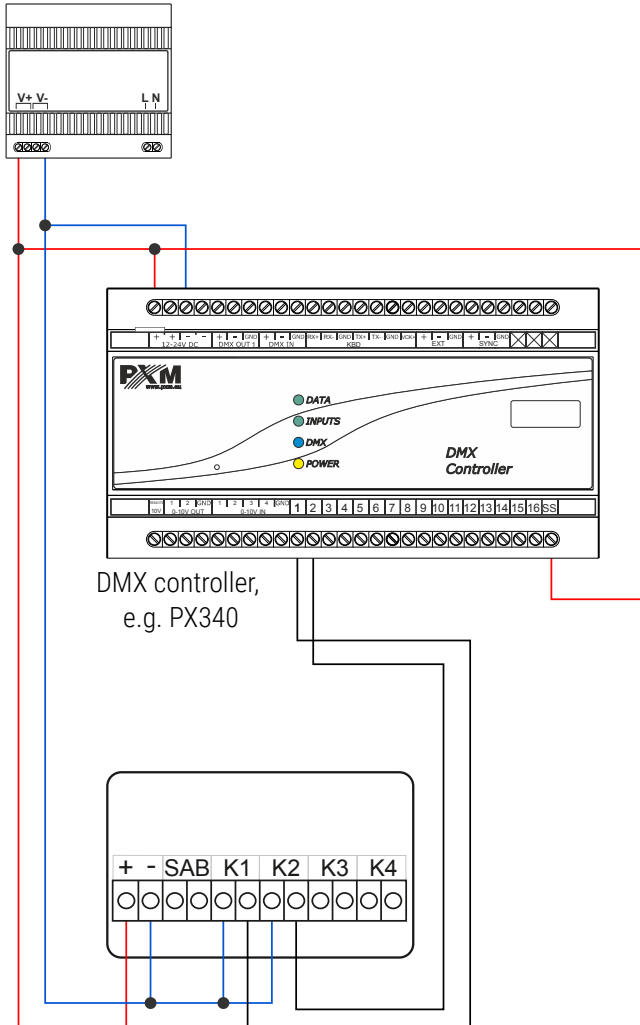

Connection PY517 with PX333 controller

power supply
12V DC

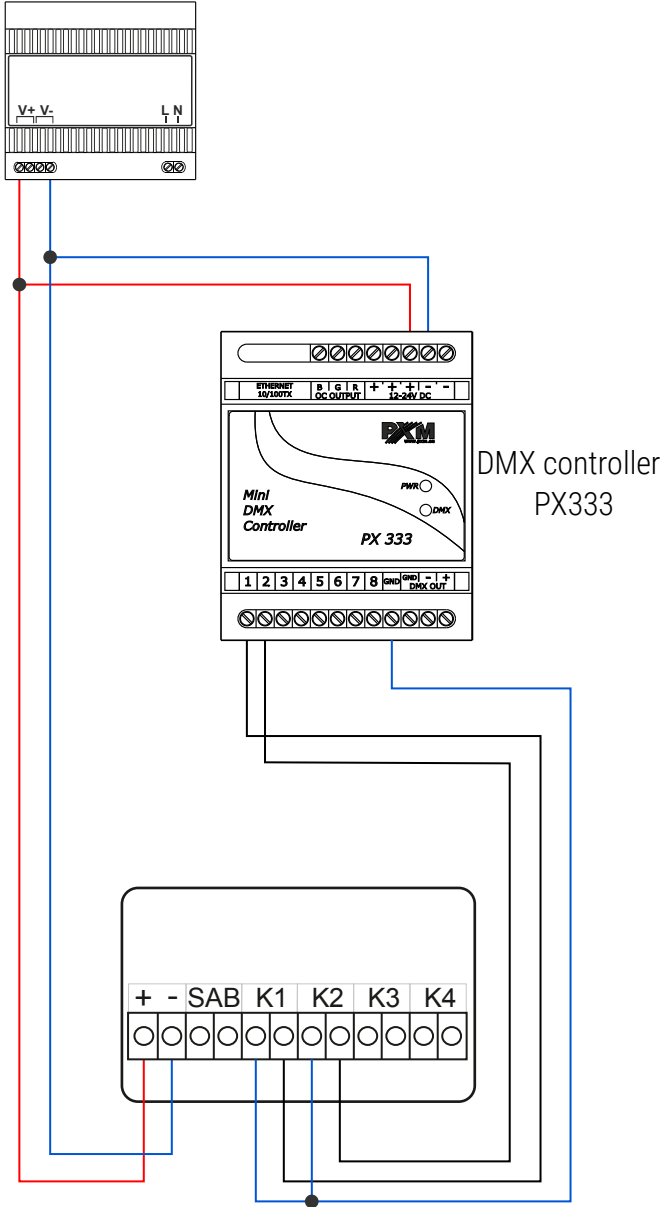

9 Technical data

type	PY517
memory capacity	40 buttons
frequency	433,92MHz
receiving module	H2 (sensitivity -114dBm)
coding	variable code
cooperation	any sA series transmitter
mounting	surface
number of relays	4
modes of operation	4
monostable time range	~1s – 4min 15s
relay output	max. 1A / 30V DC
tamper output	50mA / 12V DC
current consumption	max. 104mA
power supply	12V DC
weight	0.04kg
dimensions	width: 68mm height: 48mm depth: 26mm