

PX816-T

PxArt+ XL

Mono DALI Track

User manual



Table of Contents

| | |
|---|----|
| 1 Description..... | 3 |
| 2 Safety conditions..... | 4 |
| 3 Information on version..... | 6 |
| 4 Lamp connection..... | 7 |
| 4.1 The cross-section of the GT® Pulse Control..... | 7 |
| 5 Connection scheme..... | 8 |
| 6 Dimensions..... | 9 |
| 7 Technical data..... | 10 |

Manufacturer reserves the right to make modifications in order to improve device operation.

PXM Marek Żupnik sp.k.
Podłęże 654
32-003 Podłęże
BDO register number 000005972

tel. +48 12 385 83 06
mail: info@pxm.pl
www.pxm.pl

Rev.1-0
15.03.2021

1 Description

PX816-T is a professional LED illuminator control via DALI protocol.

By using semiconductor light sources SSL LED COB type and advanced control electronics, a high-class illuminator has been created. Its most advantages include the total lack of ultraviolet radiation, trace amounts of infrared radiation, very high CRI color rendering index, high brightness and low energy consumption.

The device has a handle that allows it to be mounted to GLOBAL Trac® Pulse Control bus-bars with an integrated power supply and DALI signal receiver.

The lamp uses a highly efficient LED diode, thanks to which the lamp emits a small amount of heat.

The lamp housing allows to change the lighting direction in two axes.

It is possible to buy a honeycomb separately, in addition, the user can replace the reflector on his own.

2 Safety conditions

Caution! Before installing, connecting and using the lamp you have to absolutely read this document.

The following symbols are used to underline important information on security on the product and in this manual.



Danger!
Risk of loss of life and health



Warning!
Fire hazard



Warning!
LED light emission, the risk of eye damage



Warning!
The risk of burns



Warning!
Read the instruction manual

Caution!

Do not look at the LEDs, LEDs can cause damage or eye irritation. Do not look at the light source with any optical devices that focus the light rays.



Light is harmful to unprotected eyes, can cause irritation, eye damage or even loss of eyesight.



While working outdoors in normal conditions, the housing unit can heat up to +65°C. Make sure that accidental contact with the device during use is impossible.



In case of improper usage of the product it may cause a risk of serious injury or death because of the threat of fire.

The PX816-T device is powered directly from 230V power grid. Failure to comply with the safety rules may result in electric shock and may endanger the user's life. Therefore it is necessary to observe the following:

1. Installation should be performed by a person holding the appropriate qualifications, according to the instruction manual.
2. The electrical installation to which the lamp is to be connected must meet the safety requirements (the installation must be 3-wire and equipped with a residual current device).
3. All the conductors should be protected against mechanical and thermal damage.
4. In the event of damaging any conductor, it should be replaced with a conductor of the same technical data.
5. All repairs, should be made with cut off power supply.
6. Do not connect to the power supply to device with visible damage.
7. All sudden shocks, particularly dropping, should be avoided.
8. The device cannot be used in places with temperature lower than $+2^{\circ}\text{C}$ or higher than $+40^{\circ}\text{C}$.
9. Clear with damp cloth only.

3 Information on version

The PX816-T lamp is available in several versions that differ.

Below is a description of the PX816-T markings and their explanation:

PX816-T – BB – XX – YYY – Z

BB – version:

XL – large COB

XX – reflector angle:

15 – 15°

36 – 36°

51 – 51°

YYY – CRI and color temperature:

X30 – CRI 95, temp. 3000K

930 – CRI 90, temp. 3000K

950 – CRI 90, temp. 5000K

830 – CRI 80, temp. 3000K

850 – CRI 80, temp. 5000K

Z – housing color:

3 – white

4 Lamp connection

The PX816-T is a device attached to the GLOBAL Trac® Pulse Control rail using an adapter with a built-in power supply included in the set.

4.1 The cross-section of the GT® Pulse Control

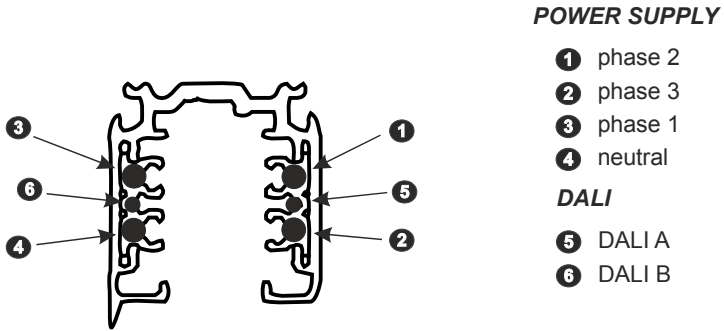

5 Connection scheme

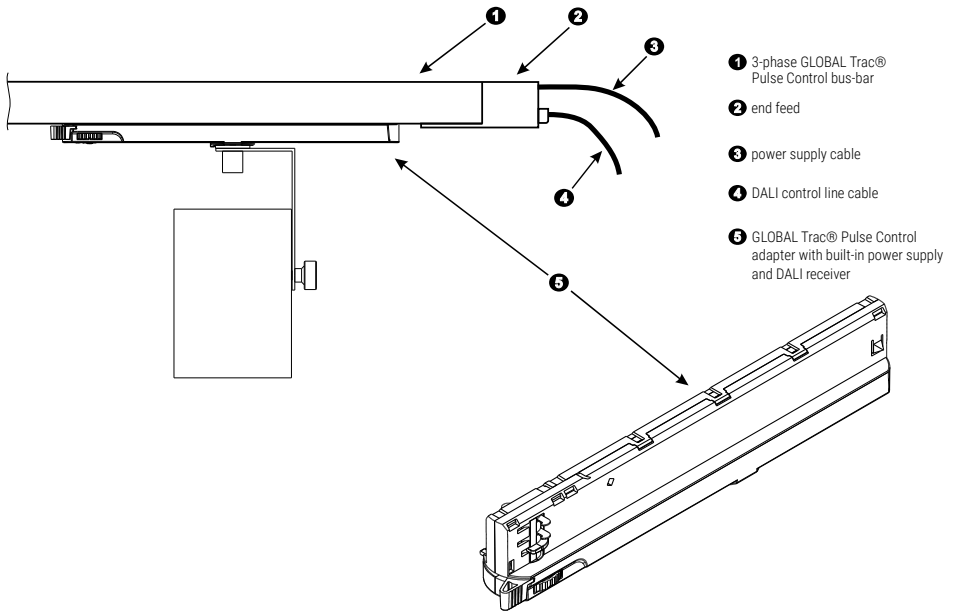

6 Dimensions

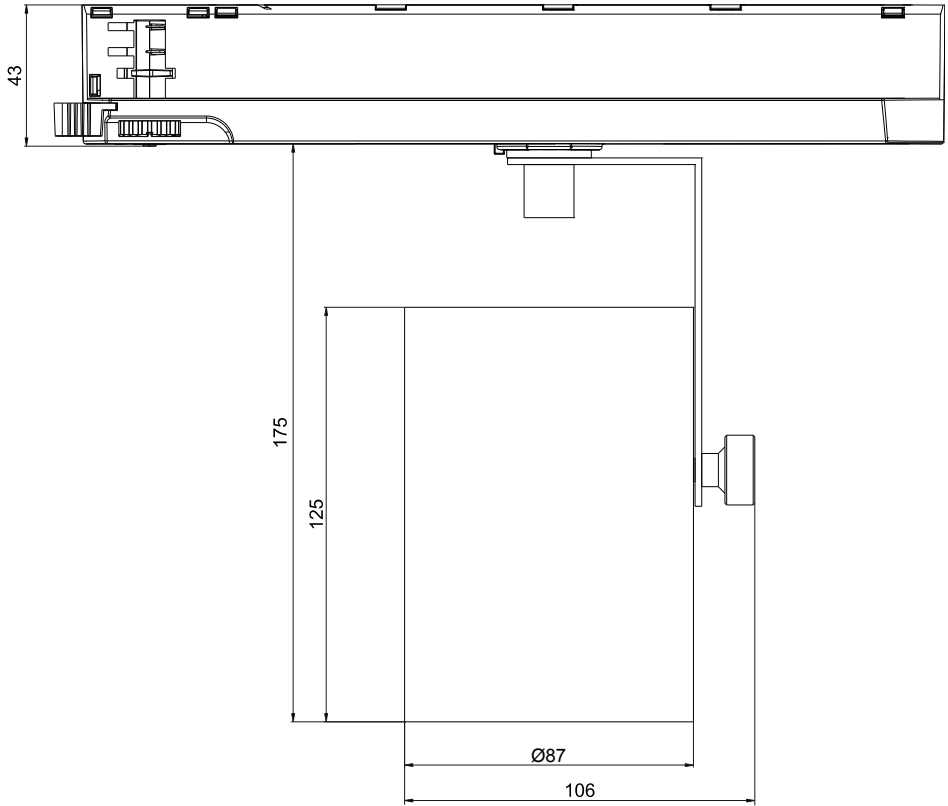

7 Technical data

| | |
|--|--|
| type | PX816-T |
| power supply | 230V AC |
| number of LEDs | 1 (COB) |
| power | 26W |
| total luminous flux | PX816-T-XL-15-930: 2463lm |
| | PX816-T-XL-36-930: 2348lm |
| | PX816-T-XL-51-930: 2350lm |
| PF (power factor) | 0,94 |
| max. increase of the housing temperature | +50°C |
| color rendering index CRI | min. 80 |
| lifetime of diodes | 50000h |
| reflector angles | 15°, 36°, 51° |
| brightness adjustment range | 0.2 – 100% |
| control | DALI |
| mounting | GLOBAL Trac [®] Pulse Control |
| available housing colors | white |
| weight | 0.8kg |
| dimensions | width: 106mm |
| | height: 175mm |
| | diameter: 87mm |

DECLARATION OF CONFORMITY

PXM Marek Żupnik spółka komandytowa
Podłęże 654, 32-003 Podłęże

we declare that our product:

Product name: PxArt+ XS / XM / XL Mono DALI
Track

Product code: PX816-T

meets the requirements of the following standards, as well as harmonised standards:

| | |
|-----------------------------|-----------------------|
| PN-EN IEC 55015:2019-11 | EN IEC 55015:2019 |
| PN-EN IEC 61000-3-2:2019-04 | EN IEC 61000-3-2:2019 |
| PN-EN 62471:2010 | EN 62471:2008 |
| PN-EN 62386-101:2015-06 | EN 62386-101:2014 |
| PN-EN 62386-102:2015-06 | EN 62386-102:2014 |

and meets the essential requirements of the following directives:

2011/65/UE **DIRECTIVE OF THE EUROPEAN PARLIAMENT AND OF THE COUNCIL** of 8 June 2011 on the restriction of the use of certain hazardous substances in electrical and electronic equipment
Text with EEA relevance.

2014/35/UE **DIRECTIVE OF THE EUROPEAN PARLIAMENT AND OF THE COUNCIL** of 26 February 2014 on the harmonisation of the laws of the Member States relating to the making available on the market of electrical equipment designed for use within certain voltage limits

Marek Żupnik spółka komandytowa
32-003 Podłęże, Podłęże 654
NIP 677-002-54-53



mgr inż. Marek Żupnik.