

PX815-2 / -L0

PX815-3 / -L0

DMX/Relay Interface 2ch

DMX/Relay Interface 3ch

User manual



Table of Contents

1 Description.....	3
2 Safety conditions.....	4
3 Connectors and control elements.....	6
4 Designation of displayed messages.....	7
5 Device programming.....	8
5.1 Button features.....	8
5.2 Information parameters.....	8
5.3 DMX address.....	9
5.4 No DMX signal response.....	10
5.5 Hysteresis thresholds.....	11
5.6 Temperature limitation.....	12
5.7 Default settings and device errors.....	13
5.7.1 Restore default settings.....	14
6 Button control.....	15
7 Device update.....	15
8 DMX signal connecting.....	16
9 RDM – available parameters.....	17
10 Programming.....	19
11 Connection scheme.....	20
12 Dimensions.....	22
13 Technical data.....	23

Manufacturer reserves the right to make modifications in order to improve device operation.

PXM Marek Źupnik sp.k.
Podłęże 654
32-003 Podłęże
BDO register number 000005972

tel. +48 12 385 83 06
mail: info@pxm.pl
www.pxm.pl

Rev.1-1
15.02.2022

1 Description

DMX/Relay Interface is a relay controlled by DMX-512 signal available in two versions: 2 or 3 channels. In the version with two channels, the possible output load is 16A / channel, while in the version with three channels up to 13A / channel.

PX815 is a device used to switch architectural illuminators or stage effects via DMX-512 signal.

The module includes relays that control the on / off outputs. The device has a user-defined hysteresis system.

The device is equipped with a DMX signal input and output. It is produced in a housing adapted for mounting on a 35mm DIN rail. The PX815 is designed to operate when connecting different phases to the control connectors. What is more, the device has been equipped with RDM protocol support.

NOTE! User-defined hysteresis thresholds are available from firmware version 1.07.

2 Safety conditions

PX815 is a device powered by 12 – 24V DC safety voltage, however, during its installation and use 230V AC voltage may be used, which may result in electric shock if the safety rules are not followed. The following rules must be strictly observed:

1. The device may only be connected to 12 – 24V DC with current-carrying capacity compatible with technical data.
2. All the conductors should be protected against mechanical and thermal damage.
3. In the event of damaging any conductor, it should be replaced with a conductor of the same technical data.
4. Connection of DMX signal can only be made with shielded conductor.
5. All repairs and connections of outputs or DMX signal can only be made with cut off power supply.
6. The PX815 should be strictly protected against contact with water and other liquids.
7. To connect the control outputs, use only cables with a cross-section of at least 2.5mm².
8. All sudden shocks, particularly dropping, should be avoided.
9. Do not connect the device with a damaged (broken) housing to the power supply.
10. The device cannot be turned on in places with humidity exceeding 90%.





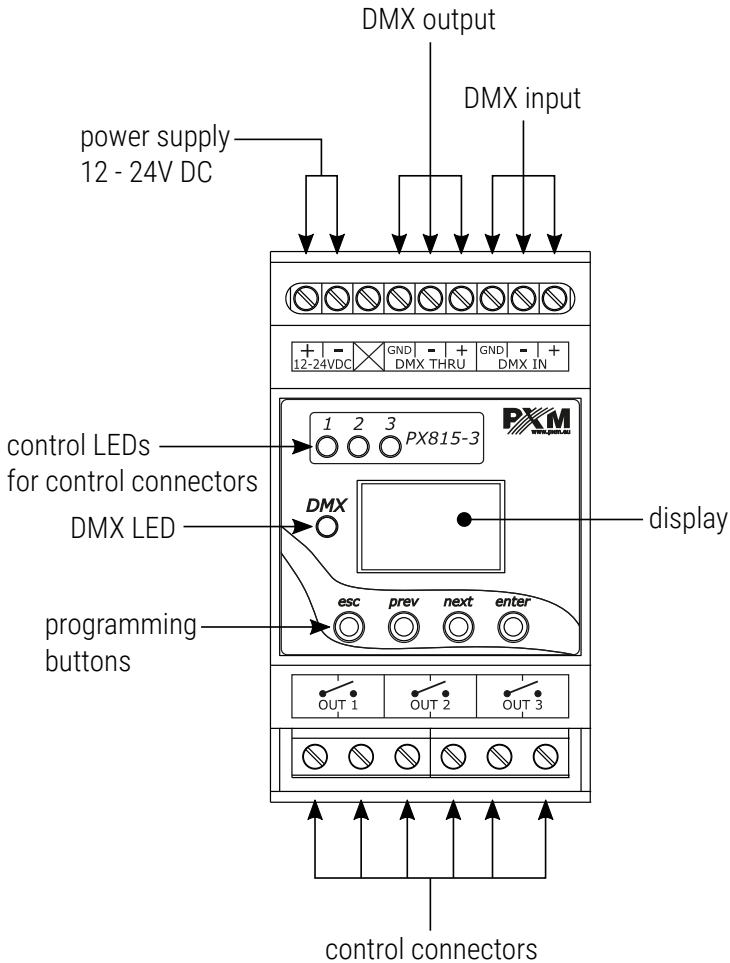











11. The device cannot be used in places with temperature lower than +2°C or higher than +40°C.
12. Clean with damp duster only – the PX815 must be completely disconnected from the power supply and control connectors at this time.
13. The relays must be protected by a (depending on version) max. 13A or max. 16A type C overcurrent fuses.

3 Connectors and control elements



NOTE! The layout of the connectors and LED signaling in the PX815-2 may differ from the version presented in the description of the connectors and control elements above (PX815-3).

4 Designation of displayed messages

	DMX address of a device – a basic item in the MENU
	information about the use of the L0 processor – appears when starting the device
	DMX address setting
	no DMX signal response method selection
	turning on the output
	turning off the output
	maintaining the last value before the disappearance of the DMX signal
	channel selection
	defining hysteresis thresholds
	device temperature
	the operating temperature has been exceeded
	thermistor shorted
	missing thermistor or thermistor open
	restore default settings on the device
	firmware version
	serial number

5 Device programming

After you switch on the module, its display shows the program version for a brief moment. To access the main menu, press **enter**, and the display will show **Adr**. Press **previous** or **next** to select the appropriate menu and press **enter** to confirm your selection.

5.1 Button features

- esc** – causes the exit from the currently programmed parameter without saving the changes or moving to the higher level in the menu
- prev** – scrolls backwards in the menu or reduces the values to be set
- next** – scrolls forwards in the menu or increases the values to be set
- enter** – causes entering the device programming and confirms the set values

5.2 Information parameters

PX815 allows to display information on the device's software version and serial number on the device screen.

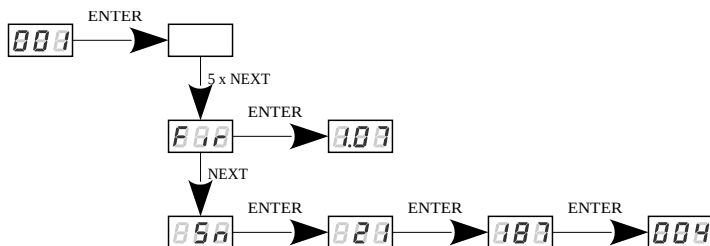

Example serial number: 21 187 004

5.3 DMX address

In the PX815 device menu, you can set the DMX address in groups for all output channels at once in the range 1 – 512.

NOTE! If, after setting the address, the channels go beyond the DMX addressing, they will be assigned to channel 512.

With the buttons *next* or *prev* you can set the DMX address by selecting a value from 1 to 512, and then confirm with the *enter* button. The set address will be assigned to the first channel, subsequent DMX addresses will be assigned to the next channels.

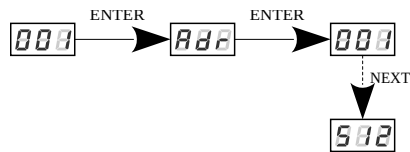

For example, for the PX815-3 version, setting the DMX 511 address will result in assigning the DMX 511 address to channel 1 and the address 512 to channels 2 and 3.

5.4 No DMX signal response

In the **ABB** menu you can set the reaction of the device to the disappearance of DMX signal for each channel individually. The possible options are:

- **OFF** – switching off the channel,
- **On** – switching on the channel,
- **HLD** – maintenance of the last DMX values.

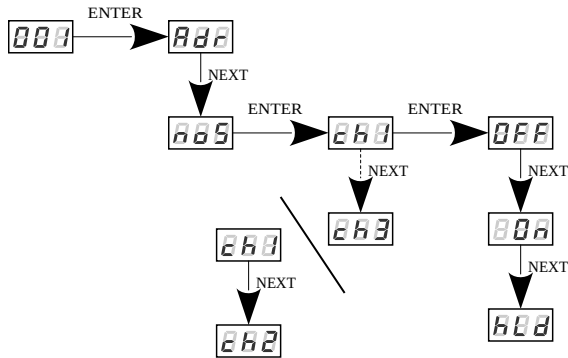

PX815-2 version

5.5 Hysteresis thresholds

The device can employ hysteresis which prevents relay contact vibration during switching on and off. Two hysteresis thresholds are applied, one for switching to the *On* position, the other – to the *OFF* position. If the *OFF* hysteresis threshold is below the *On*, a normal characteristic is obtained. If the *OFF* hysteresis threshold is above the *On*, a reversed control characteristic is obtained. If the thresholds are identical, the channel will be switched on at all times.

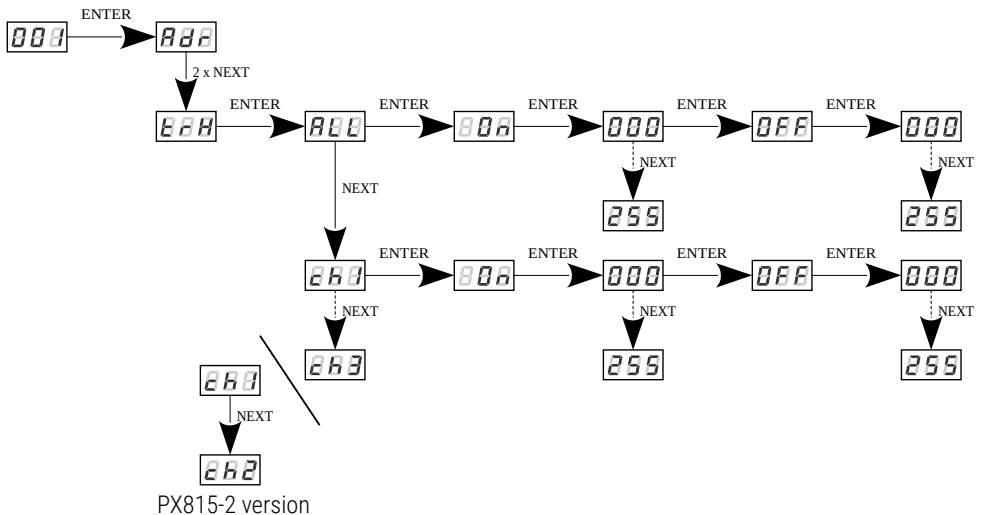

ALL – setting an *On* and *OFF* hysteresis threshold for 2 or 3 channels at the same time (in the range of 0 – 255)

ch1 – ch3 – setting an *On* and *OFF* hysteresis threshold for individual channels

NOTE! User-defined hysteresis thresholds are available from firmware version 1.07.

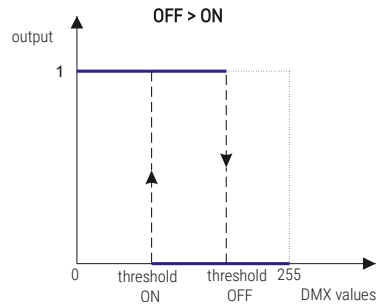
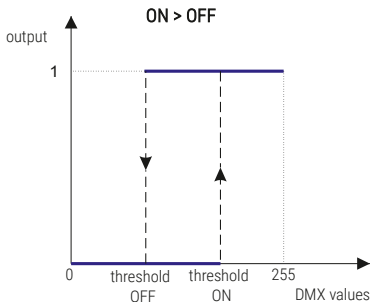

5.6 Temperature limitation

You can read the device temperature in the `ENTP` menu. The value is expressed in [°C].

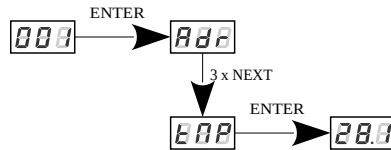

The device has implemented switching off the device after exceeding the temperature of +80°C. Reactivation will take place after the device cools down to the temperature of +70°C.

If the temperature is exceeded, the screen alternately displays the DMX address and the `H88E` message, and the LEDs of the control connectors blink.

The operation of this function is shown in the diagram below:

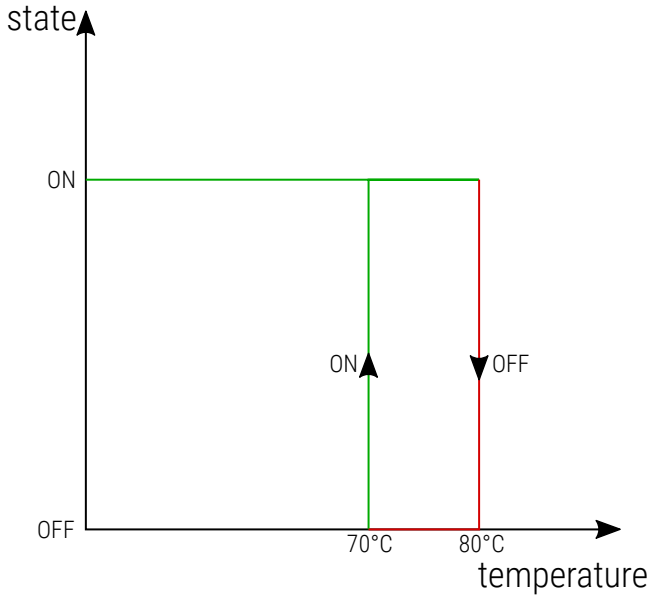

5.7 Default settings and device errors

If you have any difficulty accessing the device menu, e.g. it is not possible to enter a particular menu level or it is necessary to restore the device to its default settings, follow the instructions below.

In the first case, when a particular menu level cannot be accessed or menu items are displayed incorrectly, this may indicate that a saving-in-memory error has occurred. In such a case, try to restore the device to its default settings before sending the PX815 to the service center. If, after restoring to its default settings, the device still does not operate correctly, please send it to our service center.

Temperature measurement error messages:

- **SHE** – thermistor shorted
- **ORS** – missing thermistor or thermistor open

NOTE! The **SHE** and **ORS** messages appear in the **ERR** temperature readout menu. If the above messages are displayed, send the device to the service center.

5.7.1 Restore default settings

In order to restore the settings to default, go to the menu **DEF** and hold the **enter** button for about 2 seconds. Then a message will appear **YES** – pressing the **enter** button will restore the default settings, and pressing the **esc** button will cancel the factory reset.

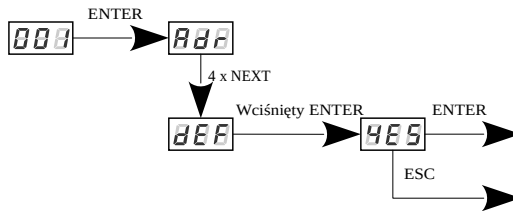

After restoring to default settings, the settings will be changed to:

- **DMX address:** 1
- **no signal mode:** off (all channels)
- **hysteresis thresholds:** On = 136 / OFF = 120

6 Button control

The combination of the **esc** (pressed) + **next / prev / enter** (1 x click) buttons allows to activate buttons or deactivate control channels.

esc + prev – enable or disable channel 1

esc + next – enable or disable channel 2

esc + enter – enable or disable channel 3

NOTE! In PX815-2, the **esc + enter** key combination is not used.

7 Device update

The update is possible using the [PX313 USB / RS485 In](#) device – details can be found in the manual for this module.



From the manufacturer's website, download the update file compatible with the version of the processor used in the device. If the **800** message appears when starting the device, it means that you need to download the firmware version adapted to *L0* processors (PX815-x-L0). If the message does not appear, download the version without *L0* in the name (PX815-x).

The device update was also presented in detail on our YouTube channel.



https://www.youtube.com/watch?v=ISIFGeXVR_k

8 DMX signal connecting

PX815 have to be connected to DMX line in serial mode, with no branches on DMX control cable. That means the DMX line, from the signal source, must be connected to **DMX IN** pins of PX815 and later, directly from **DMX THRU** pins to the next device in DMX chain.

If the PX815 is the last DMX chain receiver there should be terminator (resistor 120 Ohm) mounted between “+” and “-” pins of **DMX THRU** section.

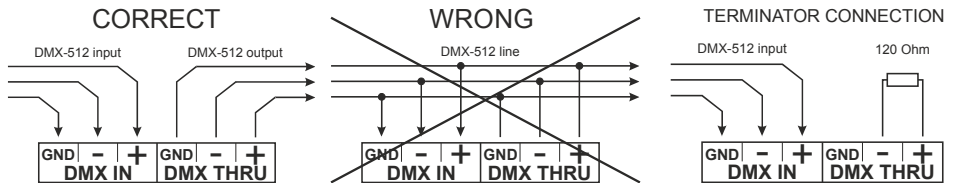

9 RDM – available parameters

The PX815 supports the DMX-RDM protocol. DMX protocol allows only of a one-way data transmission, while its extension the RDM protocol can transmit information in two directions. This makes possible to simultaneously send and receive information, and hence the possibility of monitoring activities of the compatible devices. Thanks to RDM some available settings of compatible devices may be programmed using this protocol.

List of RDM parameters supported by the PX815:

Parameter name	PiD	Description
SUPPORTED_PARAMETERS	0x0050	all supported parameters
PARAMETER_DESCRIPTION	0x0051	description of additional parameters
DEVICE_INFO	0x0060	information concerning the device
SOFTWARE_VERSION_LABEL	0x00C0	firmware version of the device
DMX_ADDRESS *	0x00F0	DMX starting address of the device; Range 1 – 512
IDENTIFY *	0x1000	device identification; Two states are possible: identification is off (0x00 value) and identification is on (0x01 value).
DEV_MODEL_DESC	0x0080	device description, e.g. name
MANUFACTURER_LABEL	0x0081	manufacturer description, e.g. name

Parameter name	PiD	Description
DEVICE_LABEL *	0x0082	additional device description; It is possible to enter an additional device description using up to 32 ASCII characters.
FACTORY_DEFAULTS	0x0090	device default settings
PERSONALITY	0x00E0	DMX operational mode
PERSONALITY_DESCRIPTION	0x00E1	description of individual operational modes
SENSOR_DEFINITION	0x0200	information on the selected temperature sensor
SENSOR_VALUE	0x0201	information on sensors
NOS1_OFF/ON/HLD *	0x801D	setting the reaction to the disappearance of DMX signal
NOS2_OFF/ON/HLD *	0x801E	setting the reaction to the disappearance of DMX signal (only in 2 and 3-channel version)
NOS3_OFF/ON/HLD *	0x801F	setting the reaction to the disappearance of DMX signal (only in 3-channel version)
SERIAL_NUMBER *	0x8030	device serial number

* - editable parameter

10 Programming

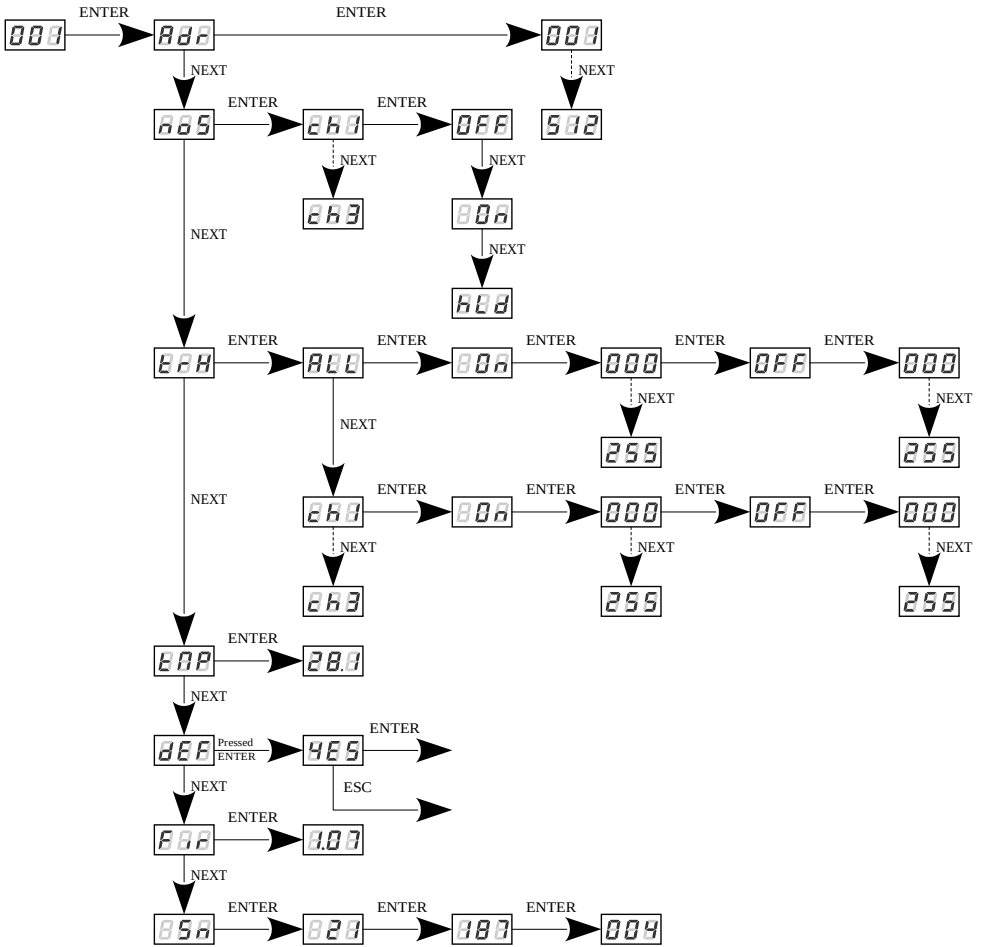

Example serial number: 21 187 004

11 Connection scheme

a) connecting device with power supply, DMX controller and outputs with different phases

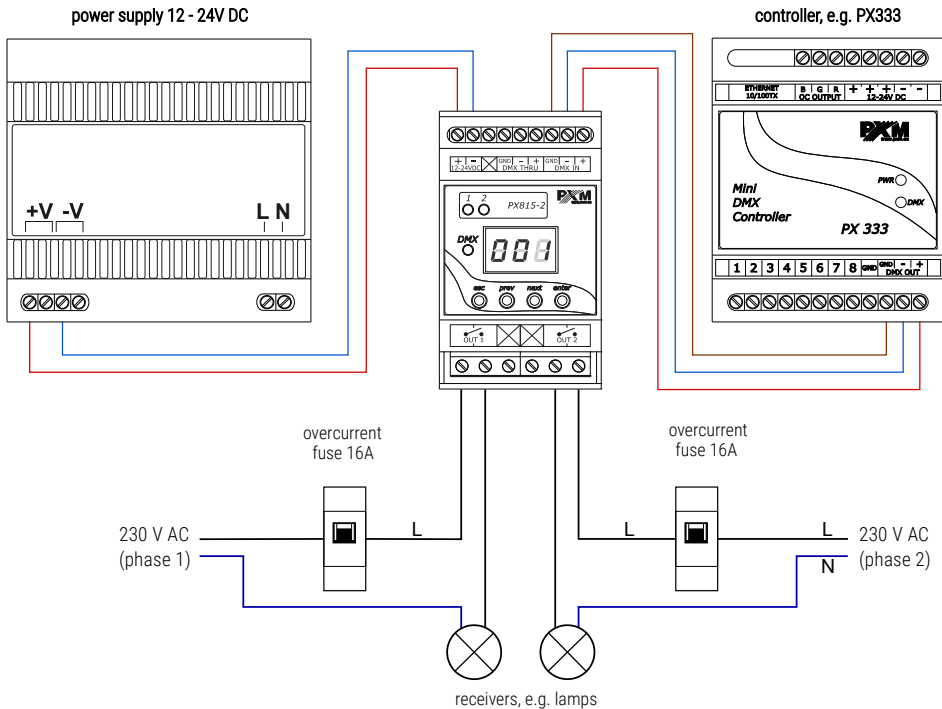

NOTE! The layout of the connectors and LED signaling in PX815-3 may differ from the version shown in the example connection diagram above (PX815-2).

b) connecting device with outputs with one phase

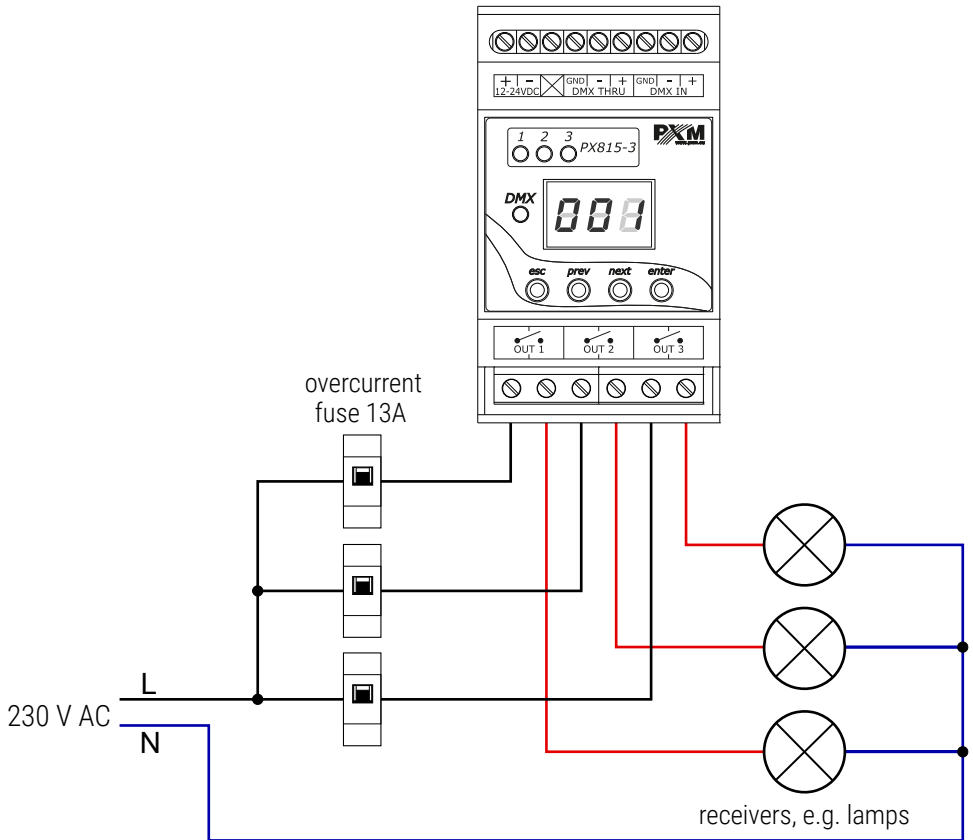

NOTE! The layout of the connectors and LED signaling in PX815-2 may differ from the version shown in the example connection diagram above (PX815-3).

NOTE! A time interval of ~100ms has been implemented between the switching on of successive outputs.

12 Dimensions

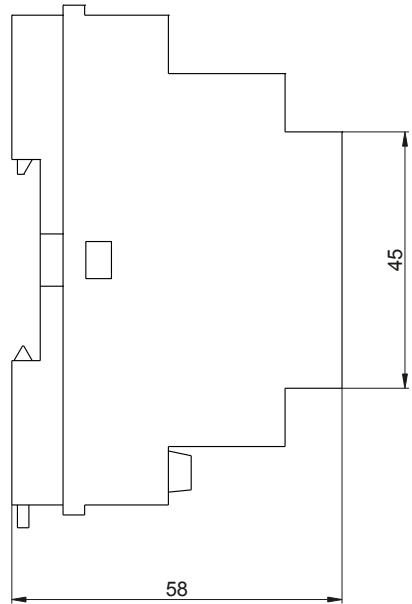
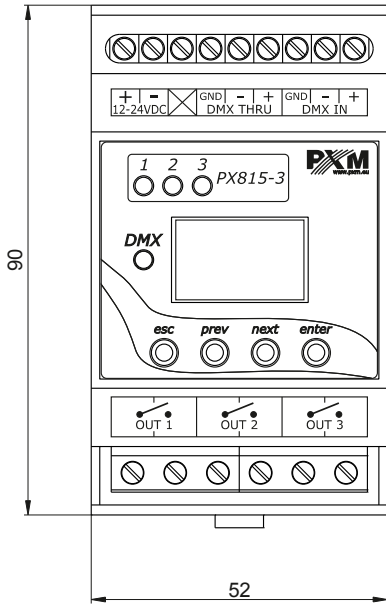

NOTE! The layout of the connectors and LED signaling in PX815-2 may differ from the version shown in the technical drawing above (PX815-3).

13 Technical data

	PX815-2
type	PX815-2-L0 PX815-3 PX815-3-L0
DMX channels	512
RDM protocol support	yes
power supply	12 – 24V DC
power consumption without load	max. 2W
number of output channels	PX815-2: 2 PX815-3: 3
output load	PX815-2: 16A / channel PX815-3: 13A / channel
relay voltage	max. 240V AC
loss of power	PX815-2: 0.5W / channel PX815-3: 0.8W / channel
maximum inrush current	500A / 2ms
output connections	screw terminal
weight	0.2kg
dimensions	width: 52mm height: 90mm depth: 58mm

DECLARATION OF CONFORMITY

PXM Marek Żupnik spółka komandytowa
Podłęże 654, 32-003 Podłęże

we declare that our product:

Product name: DMX/Relay Interface 2ch
DMX/Relay Interface 3ch

Product code: PX815-2
PX815-2-L0
PX815-3
PX815-3-L0

meets the requirements of the following standards, as well as harmonised standards:

PN-EN IEC 63000:2019-01	EN IEC 63000:2018
PN-EN 61000-4-2:2011	EN 61000-4-2:2009
PN-EN IEC 61000-6-1:2019-03	EN IEC 61000-6-1:2019
PN-EN 61000-6-3:2008	EN 61000-6-3:2007

and meets the essential requirements of the following directives:

2011/65/UE **DIRECTIVE OF THE EUROPEAN PARLIAMENT AND OF THE COUNCIL** of 8 June 2011 on the restriction of the use of certain hazardous substances in electrical and electronic equipment Text with EEA relevance.

2014/30/UE **DIRECTIVE OF THE EUROPEAN PARLIAMENT AND OF THE COUNCIL** of 26 February 2014 on the harmonisation of the laws of the Member States relating to electromagnetic compatibility (recast) Text with EEA relevance.

Marek Żupnik spółka komandytowa
32-003 Podłęże, Podłęże 654
NIP 677-002-54-53



mgr inż. Marek Żupnik.