

PX803-T

# PxArt+ XL Mono Track

User manual



# Table of Contents

1 Description.....	3
2 Safety conditions.....	4
3 Connectors and control elements.....	6
4 Information on version.....	6
5 DMX connection.....	8
5.1 GLOBAL Trac® GAC 600 adapter.....	8
5.2 The cross-section of the DMX GLOBAL Trac® Pulse Control.....	8
6 Control.....	9
6.1 Button.....	9
6.2 DMX signal.....	10
7 Cooperating with the PX277 configurator.....	10
7.1 Available parameters.....	11
7.2 The PX803-T menu diagram in PX277.....	13
8 RDM – available parameters.....	14
9 Connection scheme.....	16
10 Dimensions.....	17
11 Technical data.....	18

*Manufacturer reserves the right to make modifications in order to improve device operation.*

PXM Marek Żupnik sp.k.

Podłęże 654

32-003 Podłęże

BDO register number 000005972

tel. +48 12 385 83 06

mail: info@pxm.pl

www.pxm.pl

Rev.1-0

04.11.2020

# 1 Description

---

PX803-T is a professional LED illuminator designed to illuminate museum or exhibition displays.

By using semiconductor light sources SSL LED COB type and advanced control electronics, a high-class illuminator has been created that meets very high requirements concerning museum and exposition lighting. Its most advantages include the total lack of ultraviolet radiation, trace amounts of infrared radiation, very high CRI color rendering index, high brightness and low energy consumption. Modern electronics allowed to create a lamp that is devoid of the effect of "light vibration" (*flicker free* technology) in the full control range, which makes it useful in the television industry.

The device features a base which allows for mounting it in GLOBAL Trac® Pulse Control bus bars, provided with an additional control line.

An individual address assigned to each lamp allows to adjust its brightness independently of the settings of other lamps. Thanks to the button placed on the housing, it can also be manually controlled (e.g. in case of connecting the lamp to bus bars without a control line).

The lamp uses a highly efficient LED diode and an effective control system, thanks to which the lamp emits a small amount of heat.

The lamp housing allows to change the lighting direction in two axes.

It is possible to buy a honeycomb separately, in addition, the user can replace the reflector on his own.

## 2 Safety conditions

---

**Caution! Before installing, connecting and using the lamp you have to absolutely read this document.**

The following symbols are used to underline important information on security on the product and in this manual.



**Danger!**  
Risk of loss of life and health



**Warning!**  
Fire hazard



**Warning!**  
LED light emission, the risk of eye damage



**Warning!**  
The risk of burns



**Warning!**  
Read the instruction manual

### **Caution!**

Do not look at the LEDs, LEDs can cause damage or eye irritation. Do not look at the light source with any optical devices that focus the light rays.



Light is harmful to unprotected eyes, can cause irritation, eye damage or even loss of eyesight.



While working outdoors in normal conditions, the housing unit can heat up to +65°C. Make sure that accidental contact with the device during use is impossible.



In case of improper usage of the product it may cause a risk of serious injury or death because of the threat of fire.

The PX803-T device is powered directly from 230V power grid. Failure to comply with the safety rules may result in electric shock and may endanger the user's life. Therefore it is necessary to observe the following:

1. Installation should be performed by a person holding the appropriate qualifications, according to the instruction manual.
2. The electrical installation to which the lamp is to be connected must meet the safety requirements (the installation must be 3-wire and equipped with a residual current device).
3. All the conductors should be protected against mechanical and thermal damage.
4. In the event of damaging any conductor, it should be replaced with a conductor of the same technical data.
5. All repairs, should be made with cut off power supply.
6. Do not connect to the power supply to device with visible damage.
7. All sudden shocks, particularly dropping, should be avoided.
8. The device cannot be used in places with temperature lower than  $+2^{\circ}\text{C}$  or higher than  $+40^{\circ}\text{C}$ .
9. Clear with damp cloth only.

### 3 Connectors and control elements

---

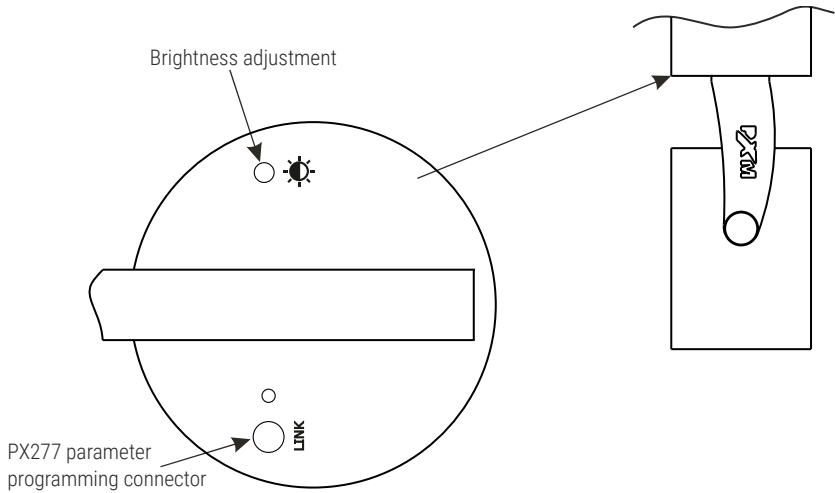

### 4 Information on version

---

The PX803-T lamp is available in several versions that differ, for example, in the angle of the lenses used.

Below is a description of the PX803-T markings and their explanation:

**PX803-T – BB – XX – YYY – Z**

**BB** – version:

XL – large COB

**XX** – reflector angle:

15 – 15°

36 – 36°

51 – 51°

**YYY** – CRI and color temperature:

X30 – CRI 95, temp. 3000K

930 – CRI 90, temp. 3000K

950 – CRI 90, temp. 5000K

830 – CRI 80, temp. 3000K

850 – CRI 80, temp. 5000K

**Z** – housing color:

1 – gray

2 – black

3 – white

# 5 DMX connection

PX803-T is a device attached to the GLOBAL Trac<sup>®</sup> Pulse Control rail by using the GAC 600 adapter included in the kit.

## 5.1 GLOBAL Trac<sup>®</sup> GAC 600 adapter

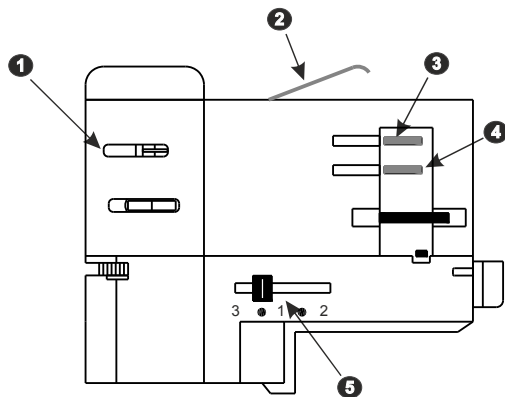

### DMX contacts

- 1 DMX - (on the opposite side DMX +)

### MAINS POWER SUPPLY

- 2 protective (⊕)
- 3 phase 1 (on the opposite side phase 2)
- 4 neutral (on the opposite side phase 3)
- 5 phase selection switch

## 5.2 The cross-section of the DMX GLOBAL Trac<sup>®</sup> Pulse Control

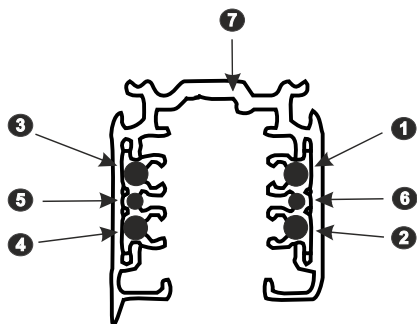

### POWER SUPPLY

- 1 phase 2
- 2 phase 3
- 3 phase 1
- 4 neutral

### DMX

- 5 DMX -
- 6 DMX +
- 7 mass (GND)



# 6 Control

---

## 6.1 Button

The lamp has been equipped with button which allow for changing the brightness level. The button have been placed at the bottom part of the junction box, above the lamp reflector.

Depending on a situation, the diode signal the following:

- start of the lamp – quick flickering of the diode for 2 seconds,
- DMX signal receiving – lighting of the brightness adjustment button in the first minute after receiving the DMX signal,
- after the start of the lamp in case of the loss of DMX signal – diode not lights,
- if the state of DMX signal changed (if there wan no DMX signal and it returned, or vice versa) – diode signals it for 1 minute,
- damage of the temperature sensor module – diode does not go out after 1 minute.

To change the brightness, press and hold down the control button. If during the brightness adjustment the button diode starts flickering, it means that the extreme value (minimum or maximum) has been reached. Then the direction of adjustment changes.

It is possible to change the adjustment direction without reaching extreme values. For example, while the lamp brightness is increased, release the control button for a moment. The diode will signal the change of

adjustment direction. The pressing of the adjustment button again will cause the dimming of the lamp (brightness decrease).

While the lamp operates, the diode stays switched off (excluding situations mentioned above).

## 6.2 DMX signal

The PX803-T lamp can be controlled via one DMX channel – lamp brightness.

Setting the lamp parameters:

	Value of the lamp parameter	Value of the DMX signal
<b>Brightness adjustment</b>	100%	255
	:	:
	50%	128
	:	:
	0%	0

## 7 Cooperating with the PX277 configurator

The PxArt+ Mono Track settings can be changed by connecting to the PX277 (PxArt+ Settings Controller) configurator. It allows in connection with PX803-T to define the following parameters: DMX addresses for brightness (in the range of 1 – 512) and device behavior in the absence of DMX signal (programmable scene).

When the lamp is connected to the configurator, the PX803-T will restart.

## 7.1 Available parameters

**DMX Addr.** – changing the DMX address of the color temperature and brightness channel in the range 1 – 512,

**No Signal** – behavior of the device when the DMX signal disappears:

- **Scene** – setting the scene displayed when the DMX signal disappears,
- **On** – switching the lamp on at 100%,
- **Off** – complete shutdown of the lamp,
- **Hold** – maintaining the last value of DMX signal,

**No Signal Time** – device reaction time after the disappearance of the DMX signal (0.0 – 10s),

**Smooth** – smooth changes in DMX signal value (*OFF / Level 1 – 4*),

**Control mode** – operating mode selection:

- **1ch MONO** – 1 DMX channel for brightness control,

**Driver temp.** – a list of the lowest, highest and current operating temperature of the power supply,

**Module temp.** – a list of the lowest, highest and current operating temperature of the module with LEDs,

**PWR time / ACT time** – total lamp operation time / total lamp lighting time,

**Factory Default** – factory reset in PX803-T:

- **DMX Addr:** 001
- **No Signal:** Scene
  - **Scene:** 128
- **No Signal Time:** 1.0 s
- **Smooth:** Level 3

- **Control Mode:** 1ch MONO

*Firmware version* – software version,

*Serial Number* – serial number.

## 7.2 The PX803-T menu diagram in PX277

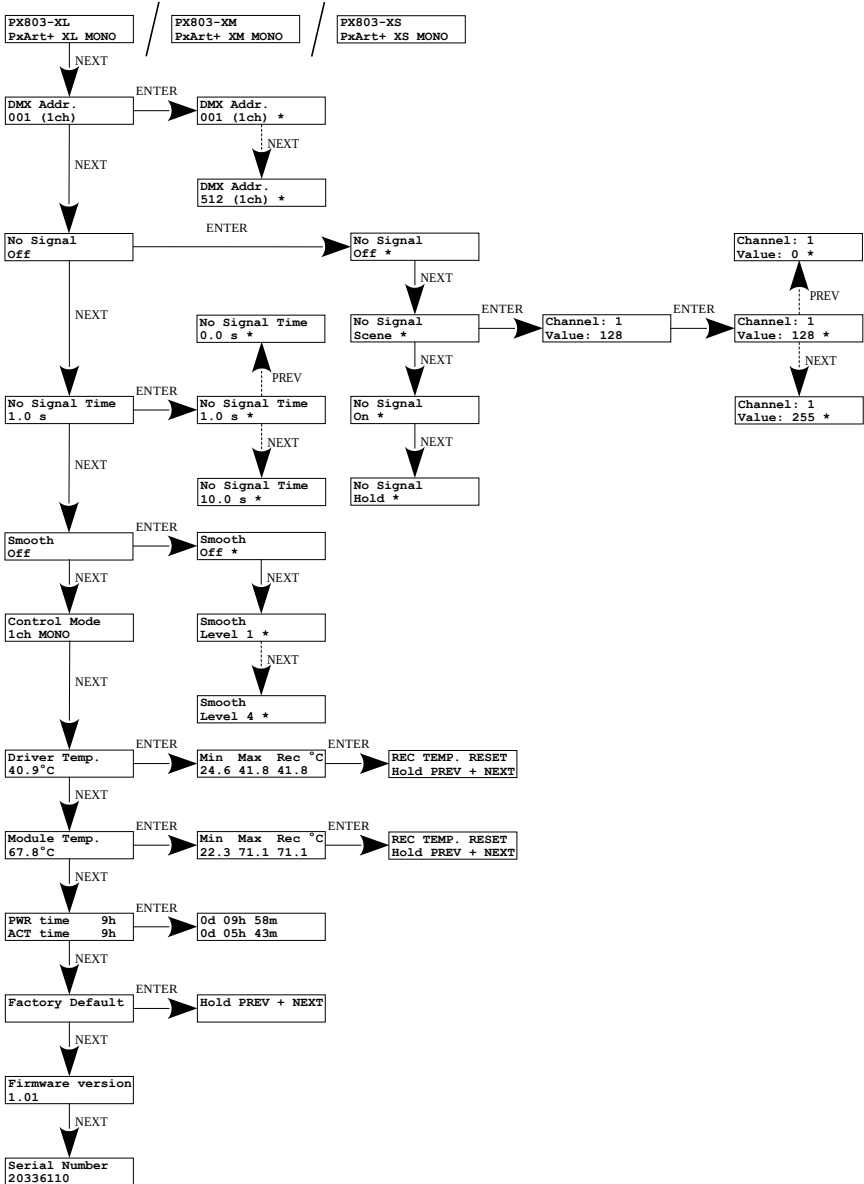

## 8 RDM – available parameters

---

The PX803-T supports the DMX-RDM protocol. DMX protocol allows only of a one-way data transmission, while extension the RDM protocol can transmit information in two directions. This makes possibility of monitoring activities of the compatible devices. Thanks to RDM some available settings of compatible devices may be programmed using this protocol.

### List of RDM parameters supported by the PX803-T:

Parameter name	PiD	Description
SUPPORTED_PARAMETERS	0x0050	all supported parameters
PARAMETER_DESCRIPTION	0x0051	description of additional parameters
DEVICE_INFO	0x0060	information concerning the device
SOFTWARE_VERSION_LABEL	0x00C0	firmware version of the device
DMX_ADDRESS *	0x00F0	DMX starting address of the device
IDENTIFY_DEVICE *	0x1000	device identification; Two states are possible: identification is off (0x00 value) and identification is on (0x01 value)
DEVICE_MODEL_DESCRIPTION	0x0080	device description, e.g. name
MANUFACTURER_LABEL	0x0081	manufacturer description, e.g. name
DEVICE_LABEL *	0x0082	additional device description; It is possible to enter an additional device description using up to 32 ASCII characters

Parameter name	PiD	Description
FACTORY_DEFAULTS	0x0090	device default settings
PERSONALITY *	0x00E0	DMX operational mode
PERSONALITY_DESCRIPTION	0x00E1	description of individual operational modes
SENSOR_DEFINITION	0x0200	information on the selected temperature sensor
SENSOR_VALUE	0x0201	information about sensors
SMOOTH_OFF/1/2/3/4 *	0x801A	selection of smoothing options
NO_SIGNAL_OFF/ON/HLD/S *	0x801C	behavior of the device when the DMX signal disappears
NOS_TIME *	0x804D	device reaction time when DMX signal disappears (0 – 10s)
NOS_SCENE_1 *	0x8021	setting channel 1 in the scene
SERIAL_NUMBER	0x8030	device serial number

\* - editable parameter

# 9 Connection scheme

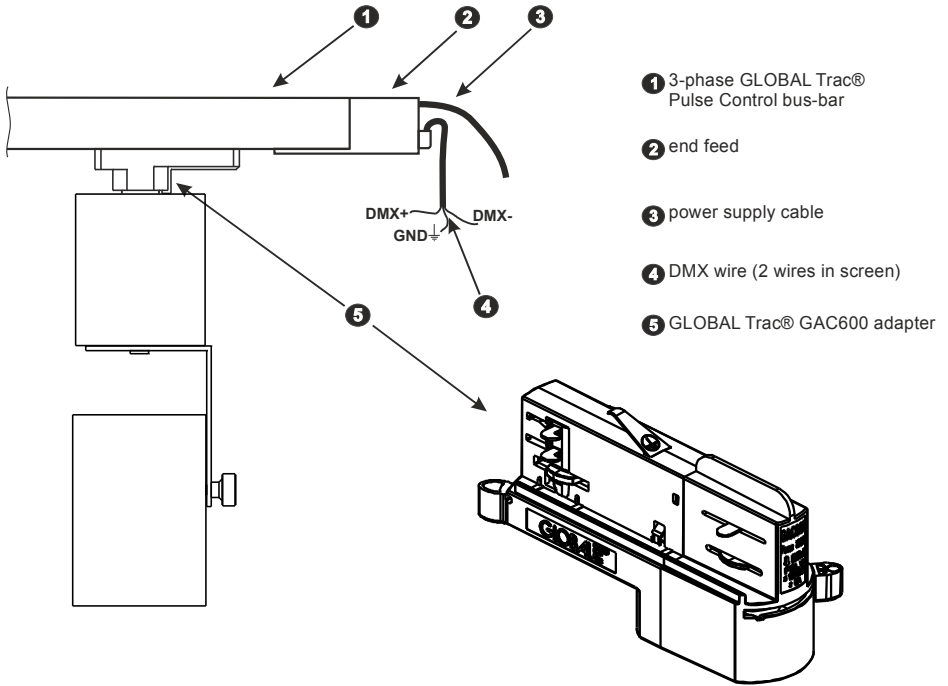



# 10 Dimensions

---

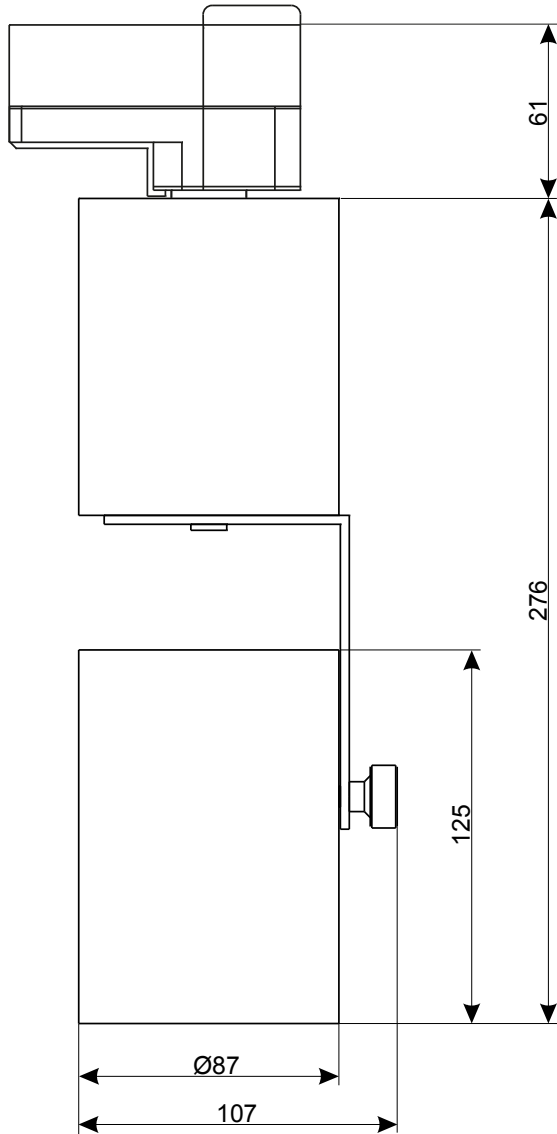

# 11 Technical data

---

type	PX803-T
power supply	230V AC
number of LEDs	1 (COB)
power	26W
total luminous flux	PX803-T-XL-15-930: 2443lm
	PX803-T-XL-36-930: 2435lm
	PX803-T-XL-51-930: 2417lm
PF (power factor)	0.94
max. increase of the housing temperature	+50°C
color rendering index CRI	min. 80
lifetime of diodes	50000h
reflector angles	15°, 36°, 51°
brightness adjustment range	0 – 100%
control	DMX / RDM
mounting	GLOBAL Trac <sup>®</sup> Pulse Control
available housing colors	gray, black, white
weight	1.3kg
dimensions	width: 107mm
	height: 276mm
	diameter: 87mm

## DECLARATION OF CONFORMITY

PXM Marek Żupnik spółka komandytowa  
Podłęże 654, 32-003 Podłęże

we declare that our product:

*Product name:* PxArt+ XS / XM / XL Mono Track

*Product code:* PX803-T

meets the requirements of the following standards, as well as harmonised standards:

PN-EN 60598-1:2015-04	EN 60598-1:2015
PN-EN 62471:2010	EN 62471:2008
PN-EN 61000-4-2:2011	EN 61000-4-2:2009
PN-EN IEC 61000-6-1:2019-03	EN IEC 61000-6-1:2019
PN-EN 61000-6-3:2008	EN 61000-6-3:2007

and meets the essential requirements of the following directives:

2011/65/UE **DIRECTIVE OF THE EUROPEAN PARLIAMENT AND OF THE COUNCIL** of 8 June 2011 on the restriction of the use of certain hazardous substances in electrical and electronic equipment  
Text with EEA relevance.

2014/30/UE **DIRECTIVE OF THE EUROPEAN PARLIAMENT AND OF THE COUNCIL** of 26 February 2014 on the harmonisation of the laws of the Member States relating to electromagnetic compatibility (recast)  
Text with EEA relevance.

2014/35/UE **DIRECTIVE OF THE EUROPEAN PARLIAMENT AND OF THE COUNCIL** of 26 February 2014 on the harmonisation of the laws of the Member States relating to the making available on the market of electrical equipment designed for use within certain voltage limits

  
**Marek Żupnik** spółka komandytowa  
32-003 Podłęże, Podłęże 654  
NIP 677-002-54-53



mgr inż. Marek Żupnik.