

PX800-W

PxArt+ 06 Wall

PxArt+ 12 Wall

PxArt+ 18 Wall

User manual



Table of Contents

1 Description.....	3
2 Safety conditions.....	4
3 Connectors and control elements.....	6
4 Information on version.....	6
5 Control.....	7
5.1 Buttons.....	7
5.2 DMX signal.....	8
6 Cooperating with the PX277 configurator.....	9
6.1 Available parameters.....	9
6.2 Scheme of the PX800-W menu in PX277.....	11
7 RDM – available parameters.....	12
8 DMX signal connecting.....	14
9 Mounting.....	14
10 Connection scheme.....	15
11 Dimensions.....	16
12 Technical data.....	17

Manufacturer reserves the right to make modifications in order to improve device operation.

PXM Marek Źupnik sp.k.
Podłęże 654
32-003 Podłęże
BDO register number 000005972

tel. +48 12 385 83 06
mail: info@pxm.pl
www.pxm.pl

Rev.1-0
08.10.2020

1 Description

PX800-W is a professional LED illuminator designed for illumination of museum exhibitions or displays. Thanks to the application of the most modern semiconductor SSL LED light sources and advanced control electronics, a high class illuminator was created which meets very high requirements for museum and exhibition lighting. Its most important advantages include a complete lack of ultraviolet radiation emission, trace amounts of infrared radiation, a very high factor of CRI color capturing, smooth adjustment of color temperature of emitted light, large brightness and small energy consumption. Modern electronics allowed to create a lamp that is devoid of the effect of "light vibration" (*flicker free* technology) in the full control range, which makes it useful in the television industry.

The device has a handle that allows it to be mounted directly to the wall.

Two individual addresses allocated to each lamp allow for independent adjustment of its brightness and color temperature, regardless of the settings of other lamps. Through push buttons located on the lamp casing it is possible to operate it manually.

Highly-effective LEDs made by Osram Oslon® are used in the lamp with an efficient control system, through which the lamp emits small amounts heat.

The lamp casing renders it possible to change the direction of its beacon in two axes.

2 Safety conditions

Caution! Before installing, connecting and using the lamp you have to absolutely read this document.

The following symbols are used to underline important information on security on the product and in this manual.



Danger!
Risk of loss of life and health



Warning!
Fire hazard



Warning!
LED light emission, the risk of eye damage



Warning!
The risk of burns



Warning!
Read the instruction manual

Caution!

Do not look at the LEDs, LEDs can cause damage or eye irritation. Do not look at the light source with any optical devices that focus the light rays.



Light is harmful to unprotected eyes, can cause irritation, eye damage or even loss of eyesight.



While working outdoors in normal conditions, the housing unit can heat up to +65°C. Make sure that accidental contact with the device during use is impossible.



In case of improper usage of the product it may cause a risk of serious injury or death because of the threat of fire.

The PX800-W device is powered directly from 230V power grid. Failure to comply with the safety rules may result in electric shock and may endanger the user's life. Therefore it is necessary to observe the following:

1. Installation should be performed by a person holding the appropriate qualifications, according to the instruction manual.
2. The electrical installation to which the lamp is to be connected must meet the safety requirements (the installation must be 3-wire and equipped with a residual current device).
3. All the conductors should be protected against mechanical and thermal damage.
4. In the event of damaging any conductor, it should be replaced with a conductor of the same technical data.
5. All repairs, should be made with cut off power supply.
6. Do not connect to the power supply to device with visible damage.
7. All sudden shocks, particularly dropping, should be avoided.
8. The device cannot be used in places with temperature lower than +2°C or higher than +40°C.
9. Clear with damp cloth only.

3 Connectors and control elements

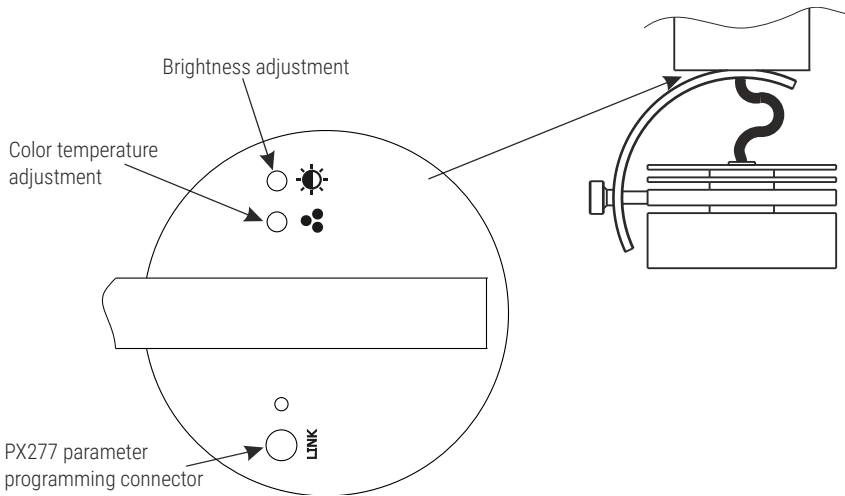

4 Information on version

Below is a description of the PX800-W model designations with their explanation

PX800-W – AA – XX – Z

AA – version:

- 06 – 6 LEDs
- 12 – 12 LEDs
- 18 – 18 LEDs

XX – beam angle:

- 10 – 10°
- 20 – 20°
- 30 – 30°
- 40 – 40°
- EL* – elliptical lenses
- WW** – Wall Washer

Z – housing colors:

- 1 – gray
- 2 – black
- 3 – white

* - not available for the PX800-W_06 lamp

** - not available for the PX800-W_06 and PX800-W_12 lamp

5 Control

5.1 Buttons

The lamp has been equipped with buttons which allow for changing the brightness level and color temperature of light. The buttons have been placed at the bottom part of the junction box, above the lamp reflector. One button is responsible for one parameter.

Depending on a situation, the diode signals the following:

- start of the lamp – quick flickering of the diode for 2 seconds
- DMX signal receiving – lighting of the brightness adjustment button in the first minute after receiving the DMX signal
- after the start of the lamp in case of the loss of DMX signal – diode not lights
- if the state of DMX signal changed (if there was no DMX signal and it returned, or vice versa) – diode signals it for 1 minute
- damage of the temperature sensor module – diode does not go out after 1 minute

To change the brightness or temperature color, press and hold down the appropriate control button. If during the brightness or color temperature adjustment the button diode starts flickering, it means that the extreme value (minimum or maximum) has been reached.

It is possible to change the adjustment direction without reaching extreme values. For example, while the lamp brightness is increased, release

the control button for a moment. The diode will signal the change of adjustment direction. The pressing of the adjustment button again will cause the dimming of the lamp (brightness decrease).

While the lamp operates, the diode stays switched off (excluding situations mentioned above).

5.2 DMX signal

The PX800-W lamp can be controlled via two DMX channels:

- Channel 1 – color
- Channel 2 – brightness

Setting the lamp parameters:

	Value of the lamp parameter	Value of the DMX signal
Adjusting the color temperature	4500K	255
	:	:
	3600K	128
	:	:
	2700K	0
Brightness adjustment	100%	255
	:	:
	50%	128
	:	:
	0%	0

6 Cooperating with the PX277 configurator

Lamp settings can be changed by connecting the PX277 configurator (PxArt+ Settings Controller) to it. It allows in connection with PX800-W to define the following parameters: DMX addresses for color and brightness separately (in the range of 1 – 512) and device behavior in the absence of DMX signal (programmable scene).

When the lamp is connected to the configurator, the PX800-W will restart.

6.1 Available parameters

DMX Addr. – changing the DMX address of the color temperature and brightness channel in the range 1 – 512,

No Signal – behavior of the device when the DMX signal disappears:

- **Scene** – setting the scene displayed when the DMX signal disappears,
- **On** – switching the lamp on at 100%,
- **Off** – complete shutdown of the lamp,
- **Hold** – maintaining the last value of DMX signal,

No Signal Time – device reaction time after the disappearance of the DMX signal (0.0 – 10s),

Smooth – smooth changes in DMX signal value (*OFF / Level 1 – 4*),

Control mode – operating mode selection:

- **2ch DW Basic** – in **DMX Addr.** One DMX address is set and the other is set automatically next,
- **2ch DW Adv.** – in **DMX Addr.** separate DMX addresses for color and brightness are set,

Driver temp. – a list of the lowest, highest and current operating temperature of the power supply,

Module temp. – a list of the lowest, highest and current operating temperature of the module with LEDs,

PWR time / ACT time – total lamp operation time / total lamp lighting time,

Factory Default – factory reset in PX800-W:

- **DMX Addr:** 001
- **No Signal:** Scene
 - **Channel 1 value:** 128
 - **Channel 2 value:** 128
- **No Signal Time:** 1.0 s
- **Smooth:** Level 3
- **Control Mode:** 2ch DW Basic

Firmware version – software version,

Serial Number – serial number.

6.2 Scheme of the PX800-W menu in PX277

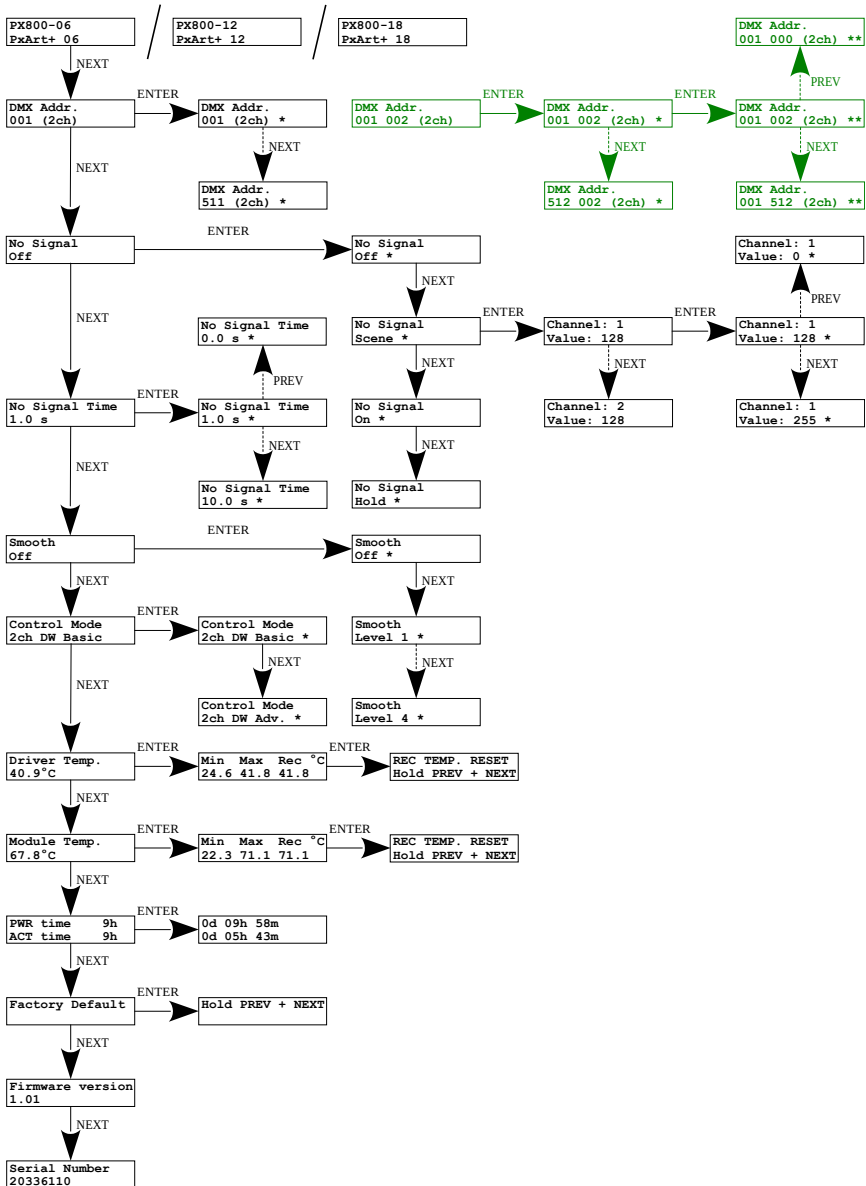

NOTE! The green color shows the DMX address setting in the *2ch DW Adv.* operating mode.

7 RDM – available parameters

The PX800-W supports the DMX-RDM protocol. DMX protocol allows only of a one-way data transmission, while extension the RDM protocol can transmit information in two directions. This makes possibility of monitoring activities of the compatible devices. Thanks to RDM some available settings of compatible devices may be programmed using this protocol.

List of RDM parameters supported by the PX800-W:

Parameter name	PiD	Description
SUPPORTED_PARAMETERS	0x0050	all supported parameters
PARAMETER_DESCRIPTION	0x0051	description of additional parameters
DEVICE_INFO	0x0060	information concerning the device
SOFTWARE_VERSION_LABEL	0x00C0	firmware version of the device
DMX_ADDRESS *	0x00F0	DMX starting address of the device
IDENTIFY *	0x1000	device identification; Two states are possible: identification is off (0x00 value) and identification is on (0x01 value)
DEV_MODEL_DESC	0x0080	device description, e.g. name
MANUFACTURER_LABEL	0x0081	manufacturer description, e.g. name
DEVICE_LABEL *	0x0082	additional device description; It is possible to enter an additional device description using up to 32 ASCII characters

Parameter name	PiD	Description
FACTORY_DEFAULTS	0x0090	device default settings
PERSONALITY *	0x00E0	DMX operational mode
PERSONALITY_DESCRIPTION	0x00E1	description of individual operational modes
SENSOR_DEFINITION	0x0200	information on the selected temperature sensor
SENSOR_VALUE	0x0201	information about sensors
SMOOTH_OFF/1/2/3/4 *	0x801A	selection of smoothing options
NO_SIGNAL_OFF/ON/HLD/S *	0x801C	behavior of the device when the DMX signal disappears
NOS_TIME *	0x804D	device reaction time when DMX signal disappears (0 – 10s)
NOS_SCENE_1 *	0x8021	setting channel 1 in the scene
NOS_SCENE_2 *	0x8022	setting channel 2 in the scene
SERIAL_NUMBER	0x8030	device serial number

* - editable parameter

8 DMX signal connecting

PX800-W must be connected to the DMX line in series, without branching on the control cable. This means that the control cable should be connected to the **DMX** pins in the PX800-W, and then from the **DMX** pins to the next DMX receivers (diagram below).

If the PX800-W is the last device in the DMX line, then a terminator – 120 Ohm resistor should be connected to the "**DMX +**" and "**DMX -**" terminals.

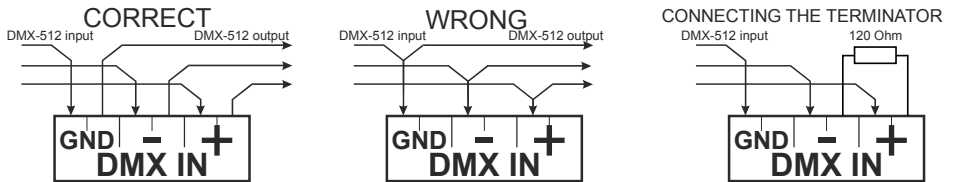

9 Mounting

To install the lamp, first attach the metal plate (hook) to the wall. Then it is possible to mount the body of the entire lamp to the wall.

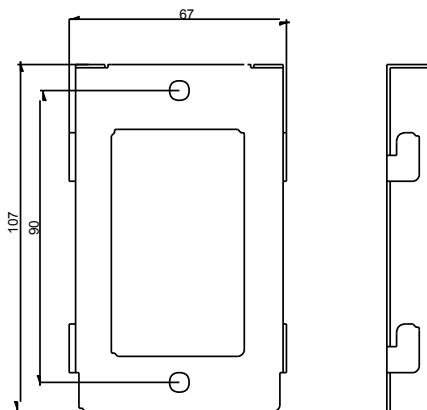

10 Connection scheme

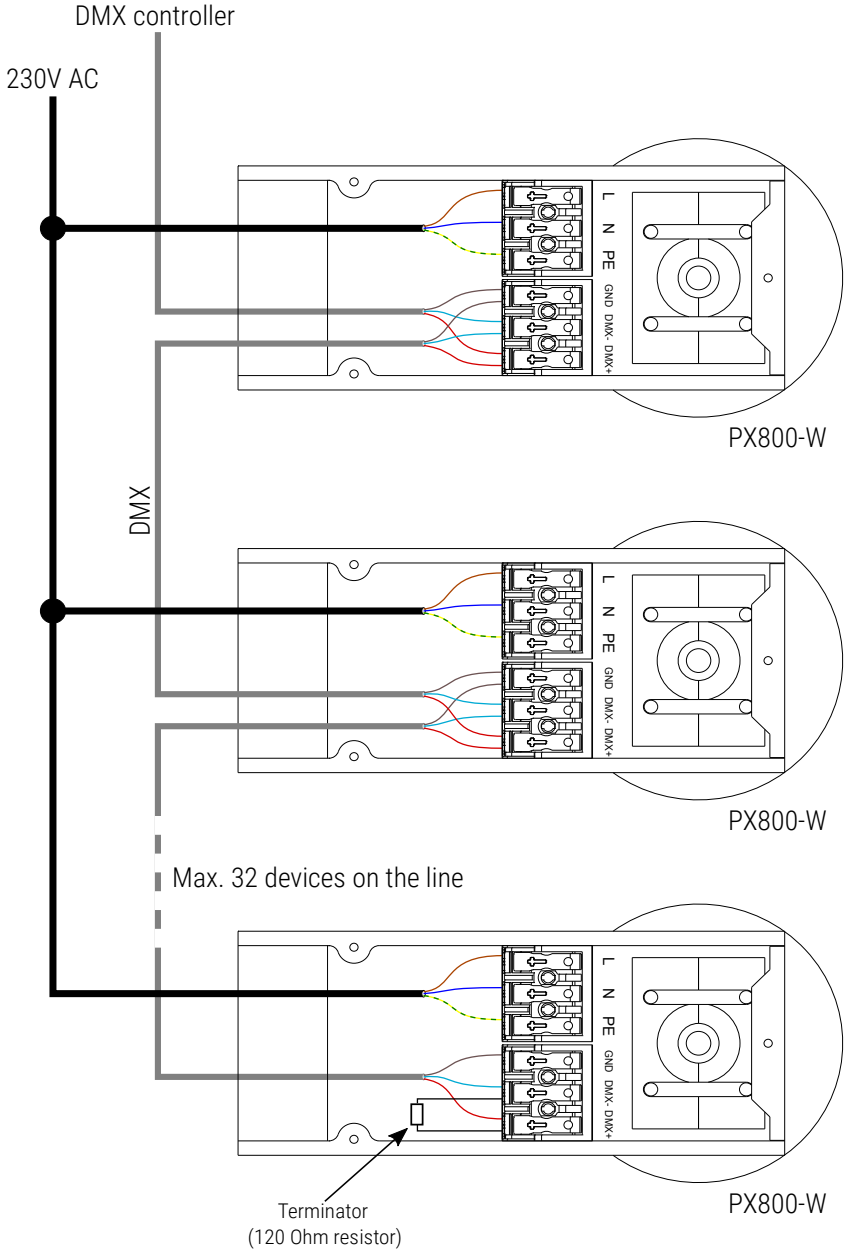

11 Dimensions

PxArt+ 06 Wall

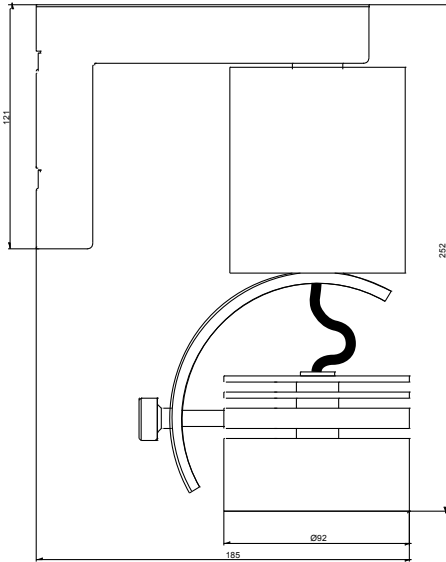

PxArt+ 12 Wall

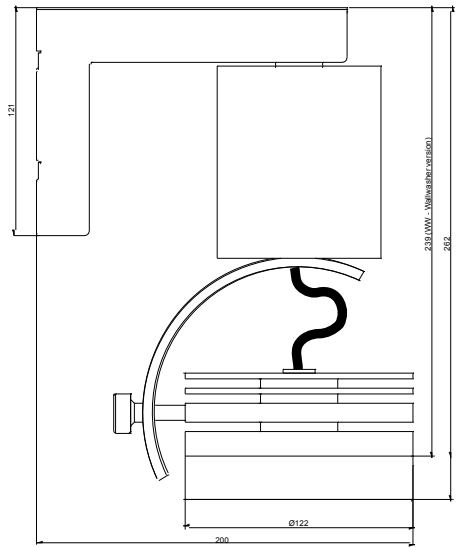

PxArt+ 18 Wall

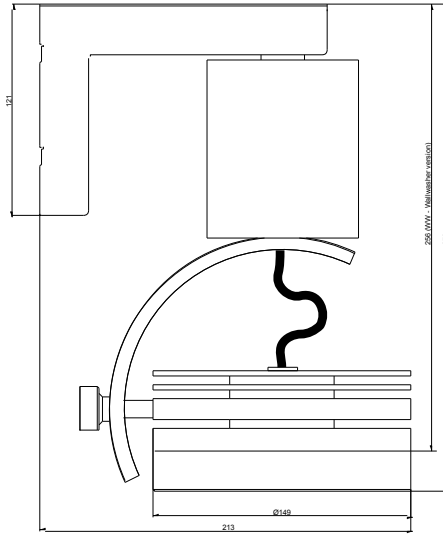

12 Technical data

type	PX800-W
power supply	230V AC
number of diodes	6 / 12 / 18
power consumption	PX800-W-06: 11W PX800-W-12: 20W PX800-W-18: 25W
max. temperature rise housing	+30°C
LEDs lifespan	50000h
beam angle	10°, 20°, 30°, 40°, EL* (10 x 45°), WW** (50 x 110°)
color temperature	2700 – 5000K
range of brightness adjustment	0 – 100%

CRI index	min. 90
control	DMX, RDM
programmable scenes	1
mounting	to the wall
available housing colors	gray, black, white
weight	PX800-W-06: 1.5kg
	PX800-W-12: 1.9kg
	PX800-W-18: 2.6kg
dimensions	height PX800-W-06: 252mm
	diameter PX800-W-06: 92mm
	height PX800-W-12: 262mm
	diameter PX800-W-12: 122mm
	height PX800-W-18: 279mm
	diameter PX800-W-18: 148mm

* - not available for the PX800-W_06 lamp

** - for a lamp equipped with WW (Wall Washer) optics the look of the reflector differs slightly (dimensions also) – not available for the PX800-W_06 and PX800-W_12 lamp

DECLARATION OF CONFORMITY

PXM Marek Żupnik spółka komandytowa
Podłęże 654, 32-003 Podłęże

we declare that our product:

Product name: PxArt+ 06/12/18 Wall

Product code: PX800-W

meets the requirements of the following standards, as well as harmonised standards:

PN-EN 60598-1:2015-04	EN 60598-1:2015
PN-EN 62471:2010	EN 62471:2008
PN-EN 61000-4-2:2011	EN 61000-4-2:2009
PN-EN IEC 61000-6-1:2019-03	EN IEC 61000-6-1:2019
PN-EN 61000-6-3:2008	EN 61000-6-3:2007

and meets the essential requirements of the following directives:

2011/65/UE **DIRECTIVE OF THE EUROPEAN PARLIAMENT AND OF THE COUNCIL** of 8 June 2011 on the restriction of the use of certain hazardous substances in electrical and electronic equipment
Text with EEA relevance.

2014/30/UE **DIRECTIVE OF THE EUROPEAN PARLIAMENT AND OF THE COUNCIL** of 26 February 2014 on the harmonisation of the laws of the Member States relating to electromagnetic compatibility (recast)
Text with EEA relevance.

2014/35/UE **DIRECTIVE OF THE EUROPEAN PARLIAMENT AND OF THE COUNCIL** of 26 February 2014 on the harmonisation of the laws of the Member States relating to the making available on the market of electrical equipment designed for use within certain voltage limits

Marek Żupnik spółka komandytowa
32-003 Podłęże, Podłęże 654
NIP 677-002-54-53



mgr inż. Marek Żupnik.