



Device description

The PX715 current driver has been designed for LED control

The built-in DMX receiver allows for controlling 4 channels (e.g. R, G, B, W) using the DMX protocol directly. The wide range of power supply voltage and high current-carrying capacity enable controlling high numbers of LEDs. It has a supply voltage of 12 – 48V DC and a maximum current-carrying capacity of 700mA max.

The PX715 can be controlled by both the DMX signal and it can work on its own. In this case, the user has a fully programmable scene and 18 pre-programmed sequences for which the playback speed and smoothness of step changing can be freely set.

Driver PX715 can operate in different control modes: **2b** – brightness and one of the 256 colors define by the manufacturer, **3b** – each color RGB can be set separately, **3bd** – each color RGB can be set separately and dimmer (dimming all outputs), **4b** – each color RGBW can be set separately, **4bd** – each color RGBW can be set separately and dimmer (dimming all outputs) **HSL** – responsible for hue, saturation and lightness, **dW** – dynamic white, control channels cold and warm white, **EFF** – it is available on 8 DMX channels and control R, G, B, W, Mode, Speed, Fade and Brightness.

The driver has a built-in *flicker free* frequency control system, which makes it especially suitable for use in the television industry.

The RGBW LEDs often differ quite substantially in parameters, this can cause problems in obtaining a white color (at full power especially). Therefore PX715 comes with a very useful function called "white balance". Thanks to it you can choose color correction for each set of LEDs controlled by the device to achieve at full power the color white.

What is more, the driver has been equipped with an output for the temperature sensor and RDM protocol support. The support of the sensor allows for power reduction depending on temperature.

Technical drawing

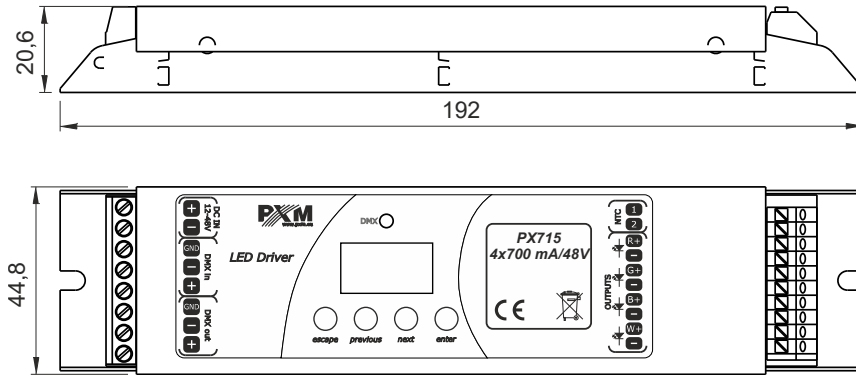

Connection diagram

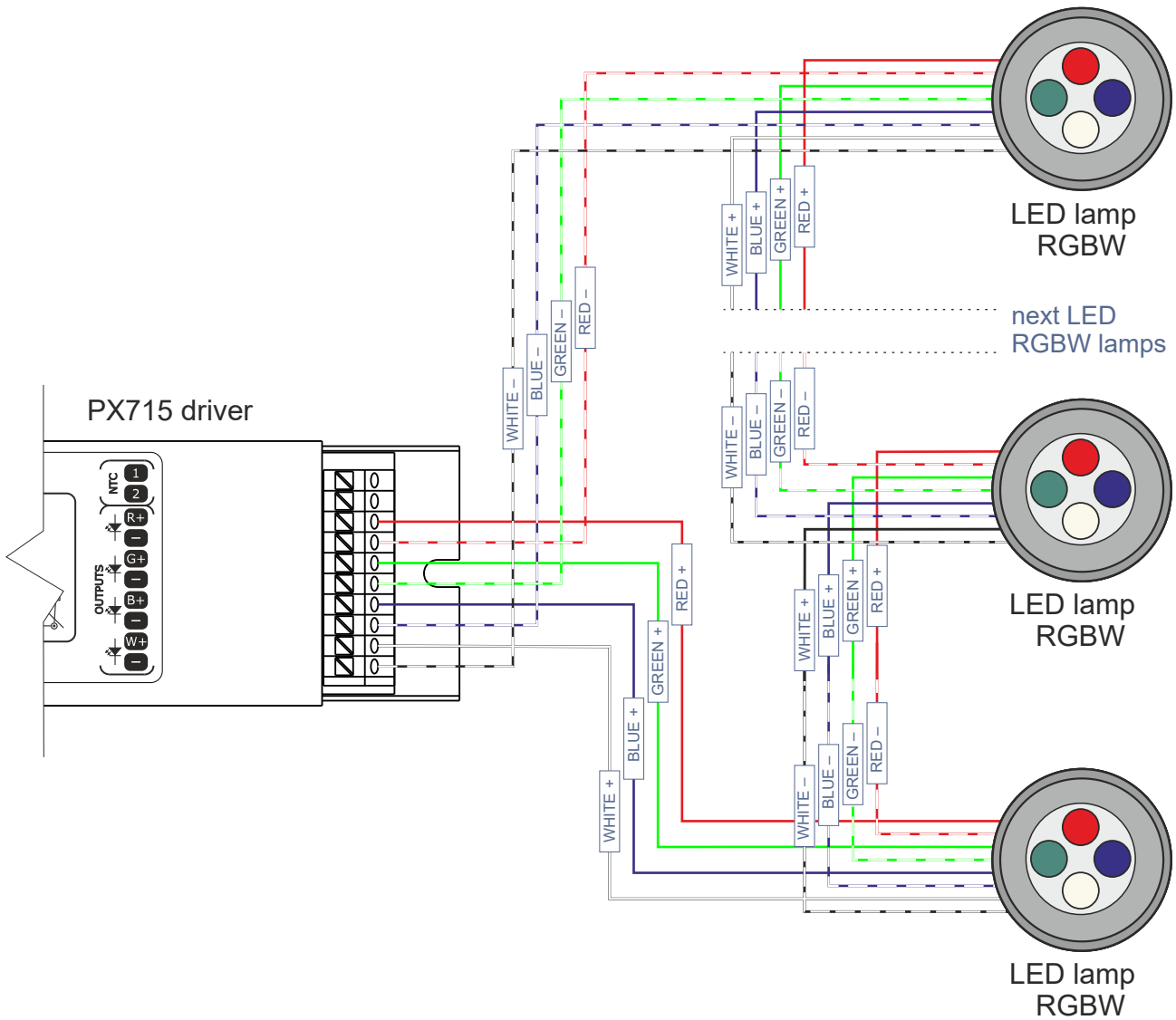

Example connection the PX714 driver to the LED lamp:

- the cables should be connected with the correct order of colors
- LEDs should be connected only in series
- controlled LEDs can be connected using two conductors only, i.e. two per channel
- the number of serially connected LEDs depends on the driver and supply voltage

LED Driver	Power supply	Number of diodes of one color
PX715	12V	1 – 3
	24V	4 – 6
	48V	7 – 12

Technical data

type	PX715 PX715-L0
DMX channels	512
RDM protocol support	yes
power supply	12 – 48V DC
max. current consumption	max. 2.8A
power consumption without load	1W
output channels number	4
interpolated resolution of output control	16 bit
programmable scenes	1
built-in programs	18
outputs load capacity	700mA / channel (+2% ÷ -5%)
output short circuit protection	yes
output sockets	screw connectors / plug connectors
plug connectors	solid wire: 0.2 – 1.5mm ² stranded wire: 0.2 – 1.5mm ² stranded wire with ferrule: 0.25 – 1mm ²
Master mode	yes
weight	0.2kg
dimensions	width: 192mm height: 44,8mm depth: 20,6mm