

PX713

# Serial Driver

User manual



# Table of Contents

1 Description.....	3
2 Safety conditions.....	3
3 Connectors and control elements.....	4
4 Cooperation with the PX277 configurator.....	5
5 Programming the device.....	6
5.1 Description of information parameters.....	6
5.2 Setting a DMX address.....	6
5.3 Number of pixels controlled.....	7
5.4 Response to DMX signal loss.....	7
5.5 Smooth.....	8
5.6 Screensaver (indicator diodes).....	9
5.7 Type of strip connected.....	9
5.8 Pixels order.....	10
5.9 Restoring factory settings.....	10
6 RDM – available parameters.....	11
7 Diagram of the PX713 menu in PX277.....	14
8 Connection scheme.....	15
9 Dimensions.....	16
10 Technical data.....	17

*Manufacturer reserves the right to make modifications in order to improve device operation.*

PXM Marek Żupnik sp.k.  
Podłęże 654  
32-003 Podłęże  
BDO register number 000005972

tel. +48 12 385 83 06  
mail: info@pxm.pl  
www.pxm.pl

Rev.1-1  
06.03.2019

# 1 Description

---

PX713 is a driver designed to control digital LED strips using the DMX512 protocol. It supports four types of strips: TLC59731, WS2811, WS2812B and WS2813. The driver allows to directly control each pixel independently.

In addition, it is possible to program “no signal” and “smooth” options. PX713 is designed to be programmed with PX277, moreover, the driver comes with the RDM protocol implemented.

## 2 Safety conditions

---

PX713 Serial Driver is a device powered with safe voltage 5 – 24V DC; however, during its installation and use the following rules must be strictly observed:

1. The device can be connected to 5 – 24V DC with current-carrying capacity compatible with technical data.
2. All the conductors should be protected against mechanical and thermal damage.
3. In case of damage to a conductor, it should be replaced with a conductor of the same technical parameters.
4. Connection of DMX signal can be made with a shielded conductor only.
5. All repairs, connecting and disconnecting cables can only be made with cut off power supply.

6. The device should be strictly protected against contact with water and other liquids.
7. All sudden shocks, particularly dropping, should be avoided.
8. The device cannot be turned on in places with humidity exceeding 90%.
9. The device cannot be used in places with temperature lower than +2°C or higher than +40°C.
10. Clean with damp cloth only.

### 3 Connectors and control elements

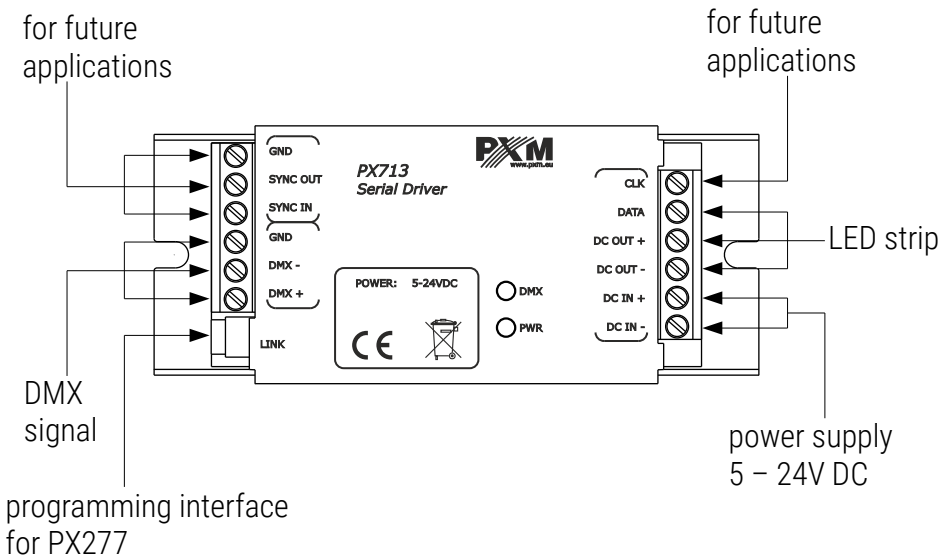

## 4 Cooperation with the PX277 configurator

---

It is possible to modify driver settings by connecting the driver to a PX277 Settings Controller. The moment of connect the PxArt Settings Controller, the PX713 will restart.

When the PX277 starts up, its name and software version will appear on the display for a short time. The main menu allows to preview many of the driver parameters and adjust the following options: DMX address, number of pixels controlled, smoothing.

PxArt Settings Controller also features an option allowing to check driver software version number, driver serial number and model.

Navigation through the menu is possible with programmer buttons located below the display. The “*escape*” button allows an exit to the upper level in the device menu; “*next*” and “*previous*” buttons make it possible to go forward and backward (alternatively value decreasing or increasing). However, the “*enter*” button allows to enter the edition of the selected menu or confirmation of the selected value.

# 5 Programming the device

## 5.1 Description of information parameters

Using the PX277 controller, it is possible to access important information about the driver to which the former is connected. These are the version number of the software in the PX713, the serial number of the driver and the model.

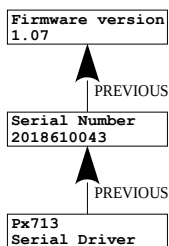

## 5.2 Setting a DMX address

By using the PX277, you can change the DMX address of your driver. A DMX channel can be set in the range from 1 to 512. You need to provide the address of the first pixel on the strip. Subsequent pixels are addressed automatically – with subsequent DMX address.

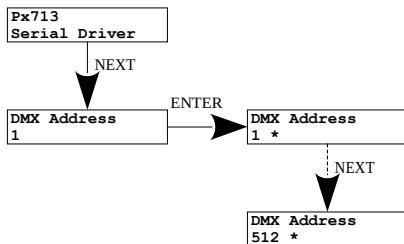

## 5.3 Number of pixels controlled

The Serial Driver allows to directly control each pixel independently. The PxArt Settings Controller has the capability to set the number of pixels controlled (within the 1 – 512 range).

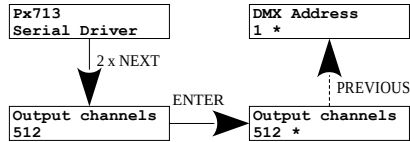

## 5.4 Response to DMX signal loss

In the **[No signal]** menu you can configure the response of the device if the DMX signal is interrupted.

Available options include:

- **Off** – switching off all the pixels
- **On** – adjusting the intensity level for all the pixels up to 100%
- **Hold** – maintaining the last value in the case of signal interruption
- **Scene** – assigning the selected brightness level to all the pixels.

Setting a value is possible in range of 0 – 255.

- **Program** – the program built into the device is implemented (all pixels are lit afterwards and then blanked)

If you connect a DMX signal, the option being executed will automatically stop and the driver will start operation in accordance with the control signal parameters. Scheme of **[No signal]** menu is on the next page.

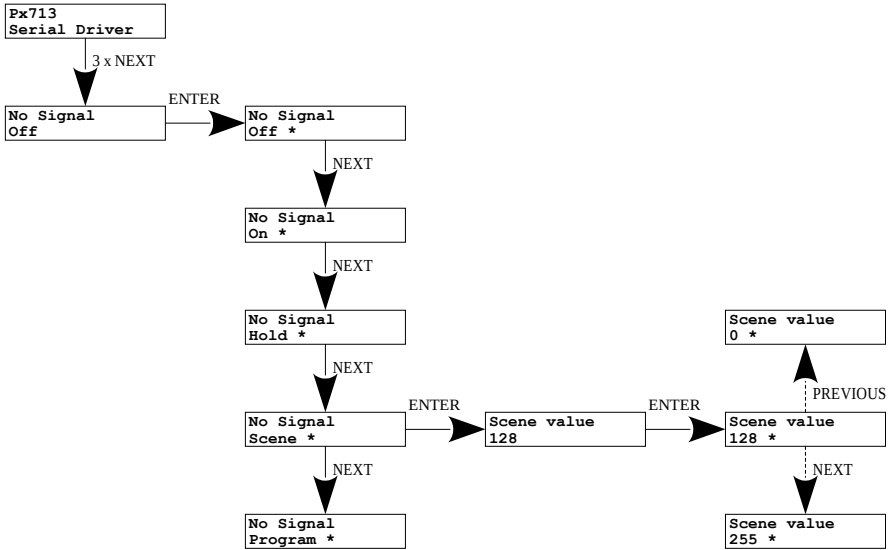

## 5.5 Smooth

The device also has a smoothing capability. This option allows for smooth operation of your digital LED strip. By default this option is activated **[On]**; in order to deactivate it, select **[Smooth]** and change from **[On]** to **[Off]**.

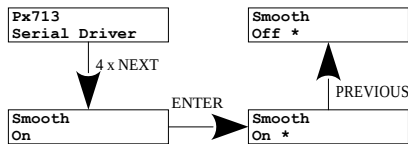



## 5.6 Screensaver (indicator diodes)

The device has a feature allowing to turn off the backlight for the DMX and PWR indicators. If the **[Screensaver]** option is enabled, the diode backlight will be switched off after 1 minute of inactivity. The device will continue running, with the other parameters being unchanged. In order to enable the backlight feature, use the PX277 keypad.

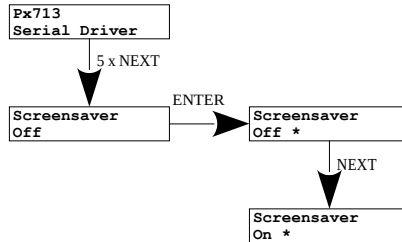

## 5.7 Type of strip connected

The driver supports four types of digital strips. You can choose: **WS2111**, **WS2112B**, **WS2113** (RGB strips) i **TLC59731** (RGB or monochromatic strip).

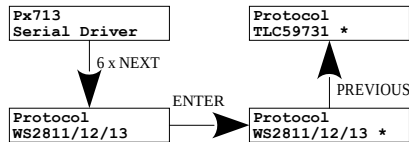

## 5.8 Pixels order

In PX713 you can change the order of pixels, the options available are: **RGB, RBG, GRB, GBR, BRG, BGR**. Changing the order of pixels is to eliminate wrong colors displayed on the digital LED strip, which may differ from each other in the order of the mounted diodes. Available only for **WS2811/12/13** type strips.

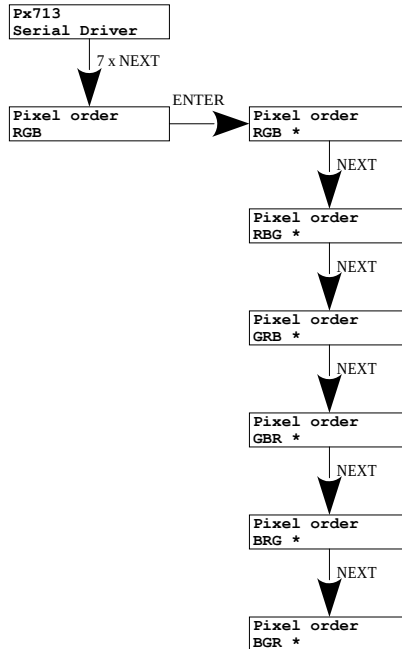

## 5.9 Restoring factory settings

There is also the option allowing to restore default settings. In order to use this option, select the **[Factory Defaults]** menu and press "enter" button in PX277.

A window will be displayed prompting you to press the “*previous*” and “*next*” keys at the same time and keep them depressed for two seconds. The device will return to the first menu item, which means that the default settings have been restored.

### PX713 default settings:

- **DMX address:** 1
- **number of pixels controlled:** 512
- **No signal:** Off
- **smoothing:** On
- **screensaver:** Off
- **type of strip connected:** WS2811/12/13
- **pixels order:** RGB

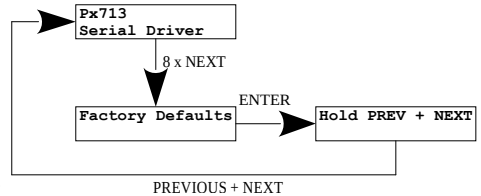

## 6 RDM – available parameters

---

PX713 supports the DMX-RDM protocol. DMX protocol in its assumption enables one-way data flow while its extension, the RDM protocol, can transmit information in two ways. This makes the simultaneous receiving and sending of information possible and allows for monitoring the operation of device compatible with the RDM protocol as well as gives the possibility of changing the configuration of their parameters.

List of supported RDM parameters by PX713:

Parameter name	PiD	Description
SUPPORTED_PARAMETERS	0x0050	all supported parameters
PARAMETER_DESCRIPTION	0x0051	description of additional parameters
DEVICE_INFO	0x0060	information concerning the device
SOFTWARE_VERSION_LABEL	0x00C0	firmware version of the device
DMX_START_ADDRESS *	0x00F0	DMX starting address of the device; Range 1 – 512
IDENTIFY_DEVICE *	0x1000	device identification; Two states are possible: identification is off (0x00 value) and identification is on (0x01 value).
DEVICE_MODEL_DESCRIPTION	0x0080	device description, e.g. name
MANUFACTURER_LABEL	0x0081	manufacturer description, e.g. name
DEVICE_LABEL *	0x0082	additional device description; It is possible to enter an additional device description using up to 32 ASCII characters.
FACTORY_DEFAULTS	0x0090	device default settings
DMX_PERSONALITY	0x00E0	DMX operational mode
DMX_PERSONALITY_DESCRIPTION	0x00E1	description of individual operational modes
SMOOTH *	0x801A	selection of the options concerning Smooth function; By default is enabled (value 1).

Parameter name	PiD	Description
NO_SIGNAL_OFF/ON/HLD/S/P *	0x801C	selection of operating mode if no DMX signal is available
NOS_SCENE *	0x8022	setting the value of a scene; Range 0 – 255
SCREENSAVER *	0x8024	screen saver setting (signaling diodes)
SERIAL_NUMBER	0x8030	device serial number
NUMBER_OF_PIXELS *	0x8046	number of pixels controlled; Range 0 – 512
PIXEL_ORDER *	0x8060	pixel order settings

\* - editable parameter



# 8 Connection scheme

Connecting power from two sources, separately to the digital LED strip and to the driver

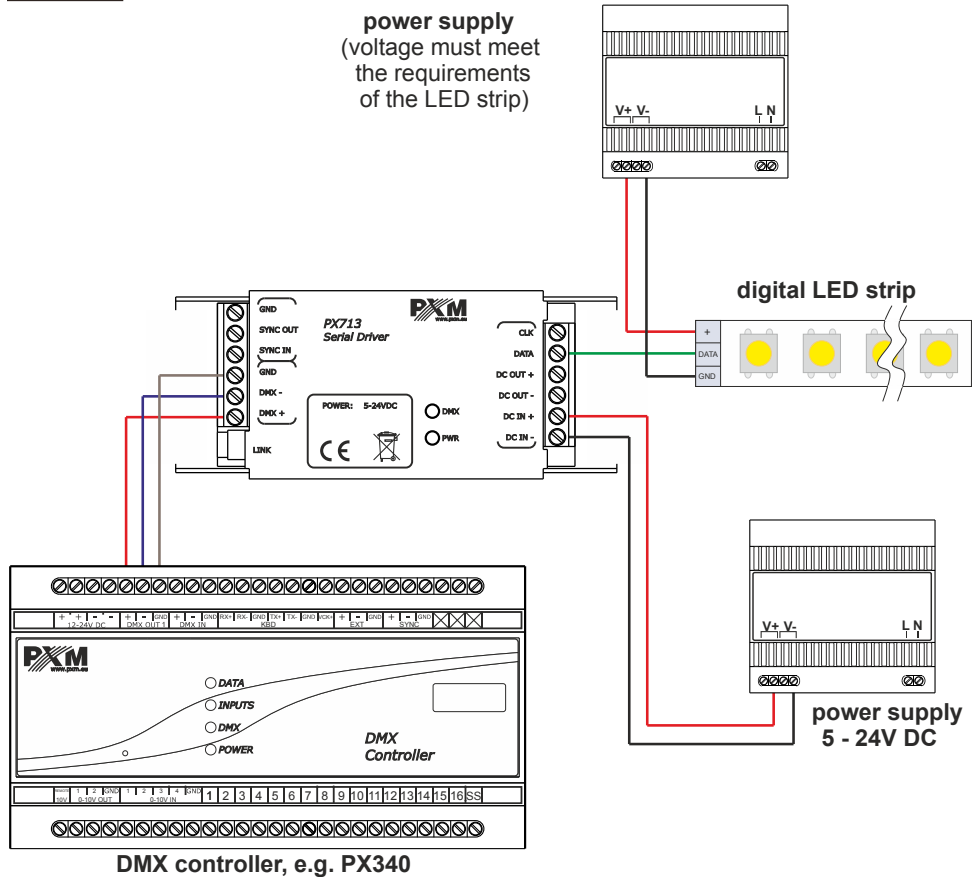

## Connecting power from one shared source to the digital LED strip and to the driver

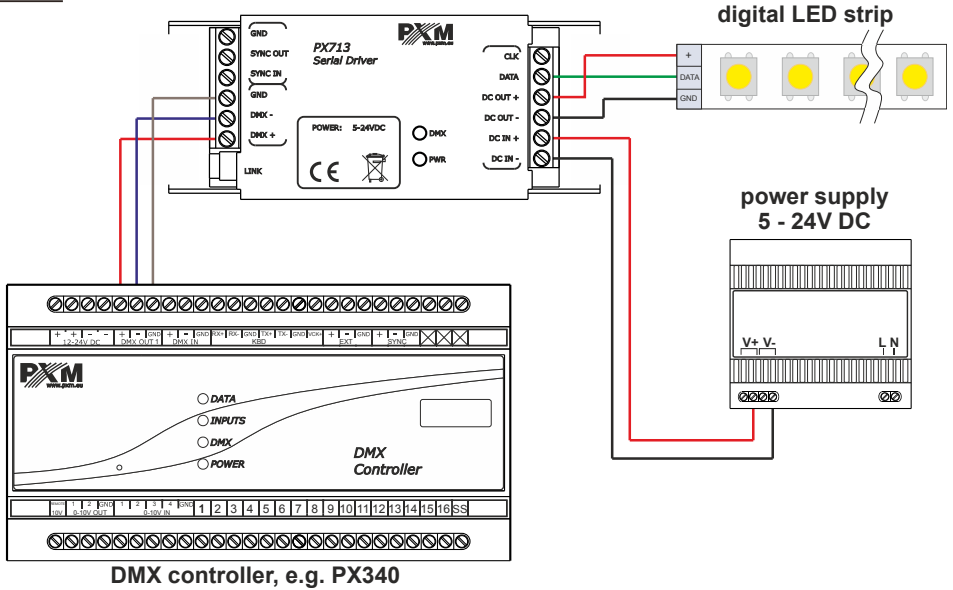

**NOTE!** The voltage of the power supply must be in accordance with the specifications of the digital LED strip. If strip must be powered by 5V DC, common power supply for the strip and the driver must be 5V DC!

## 9 Dimensions

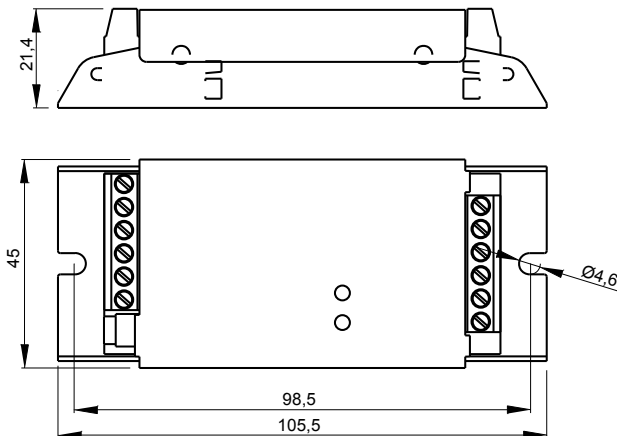



## 10 Technical data

---

type	PX713
power supply	5 – 24V DC
DMX channels	512
current consumption without load	90mA for 5V DC 30mA for 24V DC
programmable scenes	1
built-in programs	1
RDM protocol support	yes
programming	using PX277
types of strips supported	TLC59731, WS2811, WS2812B, WS2813
output connectors	terminal block
weight	0,1kg
dimensions	width: 105,5mm height: 45mm depth: 21,4mm

## DECLARATION OF CONFORMITY

PXM Marek Żupnik spółka komandytowa  
Podłęże 654, 32-003 Podłęże

we declare that our product:

*Product name:* Serial Driver

*Product code:* PX713

meets the requirements of the following standards, as well as harmonised standards:

PN-EN IEC 63000:2019-01	EN IEC 63000:2018
PN-EN 61000-4-2:2011	EN 61000-4-2:2009
PN-EN IEC 61000-6-1:2019-03	EN IEC 61000-6-1:2019
PN-EN 61000-6-3:2008	EN 61000-6-3:2007

and meets the essential requirements of the following directives:

2011/65/UE **DIRECTIVE OF THE EUROPEAN PARLIAMENT AND OF THE COUNCIL** of 8 June 2011 on the restriction of the use of certain hazardous substances in electrical and electronic equipment  
Text with EEA relevance.

2014/30/UE **DIRECTIVE OF THE EUROPEAN PARLIAMENT AND OF THE COUNCIL** of 26 February 2014 on the harmonisation of the laws of the Member States relating to electromagnetic compatibility (recast)  
Text with EEA relevance.

  
**Marek Żupnik** spółka komandytowa  
32-003 Podłęże, Podłęże 654  
NIP 677-002-54-53



mgr inż. Marek Żupnik.