

PX357+

Gate 4 DMX

User manual



Table of Contents

1 Description.....	3
2 Safety conditions.....	4
3 Connectors and control elements.....	5
4 Programming the device.....	6
4.1 Button features.....	6
4.2 Description of information parameters.....	7
4.3 Network settings.....	7
4.4 DMX IN / OUT port settings.....	8
4.5 Art-Net configuration in mode Art-Net → DMX.....	9
4.6 Art-Net configuration in mode DMX → Art-Net.....	13
4.7 Presets menu.....	14
4.8 Settings for the other parameters.....	15
5 Information communicated by LED indicators.....	16
6 Art-Net commands.....	18
7 Upgrade.....	19
8 Connection scheme.....	21
9 Dimensions.....	22
10 Technical data.....	23

Manufacturer reserves the right to make modifications in order to improve device operation.

PXM Marek Źupnik sp.k.

Podłże 654

32-003 Podłże

BDO register number 000005972

tel. +48 12 385 83 06

mail: info@pxm.pl

www.pxm.pl

Firm. 1.08

Rev.1-3

02.11.2021

1 Description

Gate 4 DMX is a gate that converts Art-Net signals to four output DMX ports and conversion of DMX512 signal to Art-Net. The device is designed to run from 230V AC mains. This gate has a solid, metal housing protecting against mechanical damage.

The device comes equipped with an Ethernet interface working in 10/100BaseTX protocol. The gate offers two modes of merging signals from two sources: HTP and LTP. The protocol version used is Art-Net 4 (compatible 1 – 4).

The DMX512 ports are optically isolated XLR connectors, resistant to mechanical damage.

In addition, on the device there are six LED indicator lights: two network ones and four showing port's status.

The gate PX357+ has a display and four buttons that allow to change the configuration: Art-Net, Ethernet and DMX settings (such as: Brake, MAB, MBF and the number of DMX channels transmitted).

The user can order additional components to be shipped with the device, allowing for: installation of a single gate in a RACK cabinet, installation of two gates in a RACK cabinet, suspending a gate (e.g. from a truss).

2 Safety conditions

Gate PX357+ is powered directly from standard 230V AC grid what can cause electric shock when safety rules are not observed.

Therefore it is necessary to observe the following:

1. Installation, particularly power connection, should be performed by a person holding the appropriate qualifications, according to instruction manual.
2. Gate can be connected only to grid, which has protecting installation in working order (3-wire grid).
3. All the conductors should be protected against mechanical and thermal damage.
4. In the event of damaging any conductor, it should be replaced with a conductor of the same technical data and attestations.
5. Device with visible mechanical damage cannot be connected to the mains.
6. All repairs, should be made with cut off power supply.
7. The device should be strictly protected against water and other liquids.
8. All sudden shocks, particularly dropping, should be avoided.
9. The device cannot be used in places with temperature lower than 2°C or higher than 40°C.
10. The device cannot be turned on in places with humidity exceeding 90%.

- 11. Clean with damp cloth only – gate should be made with cut off power supply.

3 Connectors and control elements

Front of the device:

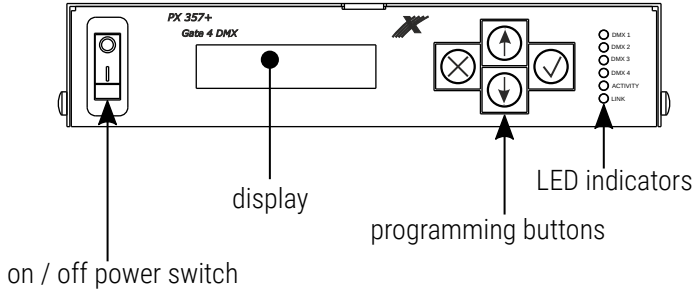

Device rear panel:

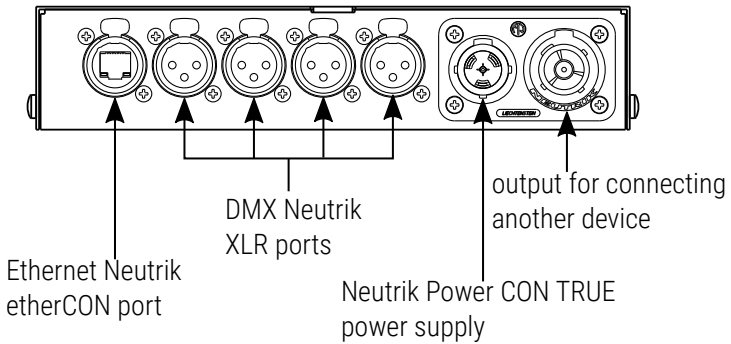

4 Programming the device

4.1 Button features

- ✕ (escape) - allows you to exit the parameter being programmed without saving any changes or to move to a higher menu level
- ↓ (next) - moves you back through the menu or decreases values being set
- ↑ (previous) - moves you forward through the menu or increases values being set
- ✓ (enter) - allows you to enter the programming mode and confirm the values set

Where a particular parameter is editable, in the bottom right-hand corner the edit symbol , and pressing ✓ allows you to proceed to edit the first field.

A field that is editable is shown within square brackets [...], and the ↓ / ↑ button allows you to change the value of such a field. If you press ✓ you will be taken to another field or the value will be saved and you will exit the edit mode for a give parameter.

The icon -> allows you to go deeper into the command tree.

4.2 Description of information parameters

The PX357+ provides you with the following device information, such as:

- gate model and current IP address (if an address is provided by DHCP, an asterisk * is added)
- gate serial number and version number of the software installed
- individual MAC address of the device

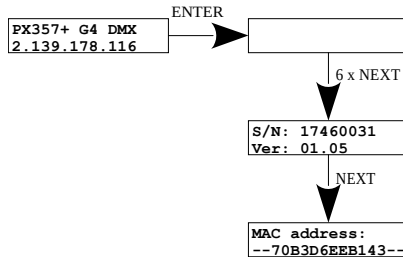

4.3 Network settings

In the **[Network config.]** menu of the device you can change the gate static IP address **[IP address]**, static sub-net mask **[Subnet mask]**, default static gate **[Gateway address]**, turn on **[On]** or turn off **[Off]** the DHCP protocol **[DHCP]**, UDP port **[UDP port]**. The default port for the Art-Net protocol is port 0x1936 (6454 decimal).

If DHCP is **turned off**, the gate operates in a static configuration (IP, SUBNET MASK, GATEWAY). If DHCP is **turned on**, the gate will start up using static settings, but will attempt to acquire new network configuration from the DHCP server.

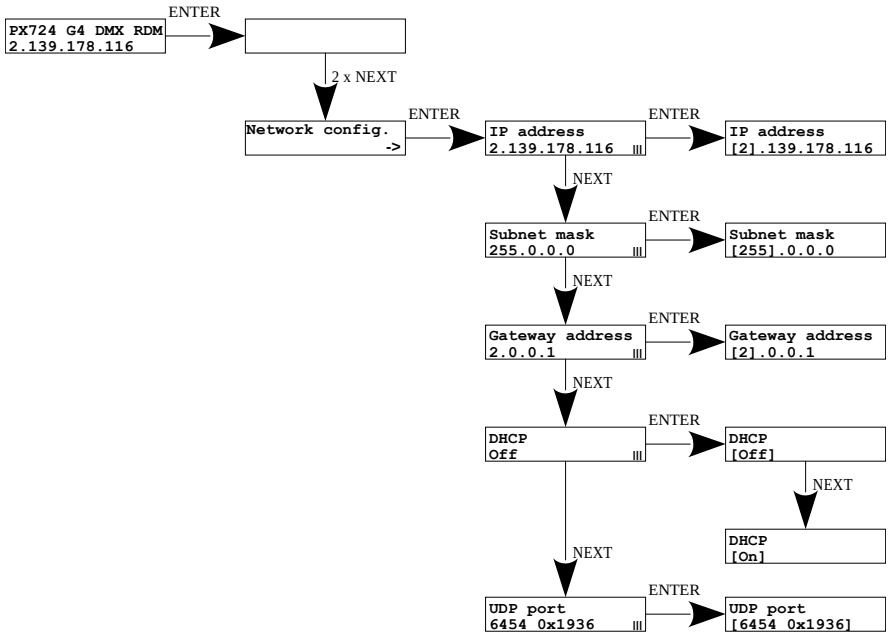

4.4 DMX IN / OUT port settings

The gate can work in two configurations of signal conversion:

Art-Net on DMX512 and DMX512 on Art-Net. To do this, the DMX 1, 2, 3 or 4 ports must be set accordingly. The options are **[in]** and **[out]**. After selecting **[out]** the signal is converted from the Art-Net network to the DMX output, analogically after selecting the **[in]** option, the signal from the DMX input is converted to Art-Net signal with the signal connection set (HTP / LTP) **[Merge mode]**. For each port, the settings can be changed in the Art-Net network configuration **[ART-NET config.]** in the **[Port n]** menu option in the **[Direction]** option. Information about the status of ports is available from the main menu.

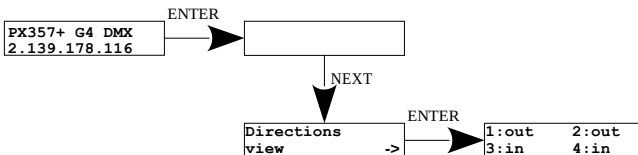

4.5 Art-Net configuration in mode Art-Net → DMX

Below is a diagram showing the [ART-NET config.] menu and a description of individual parameters that can be changed depending on the user's needs.

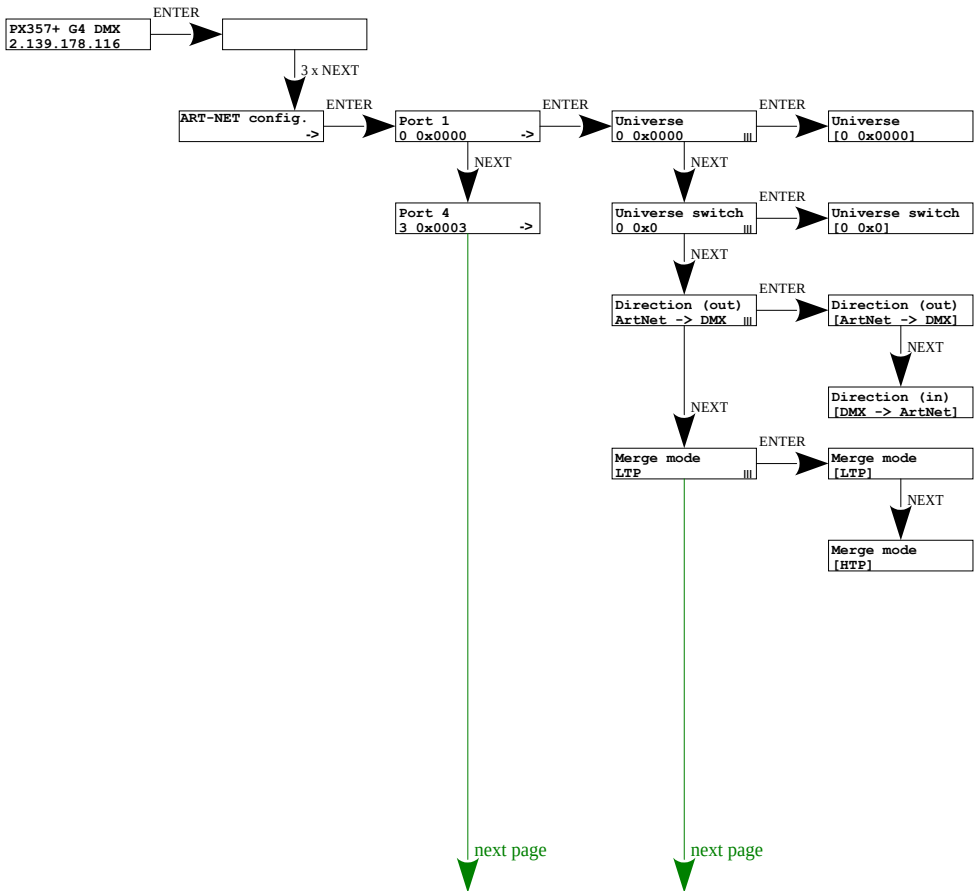

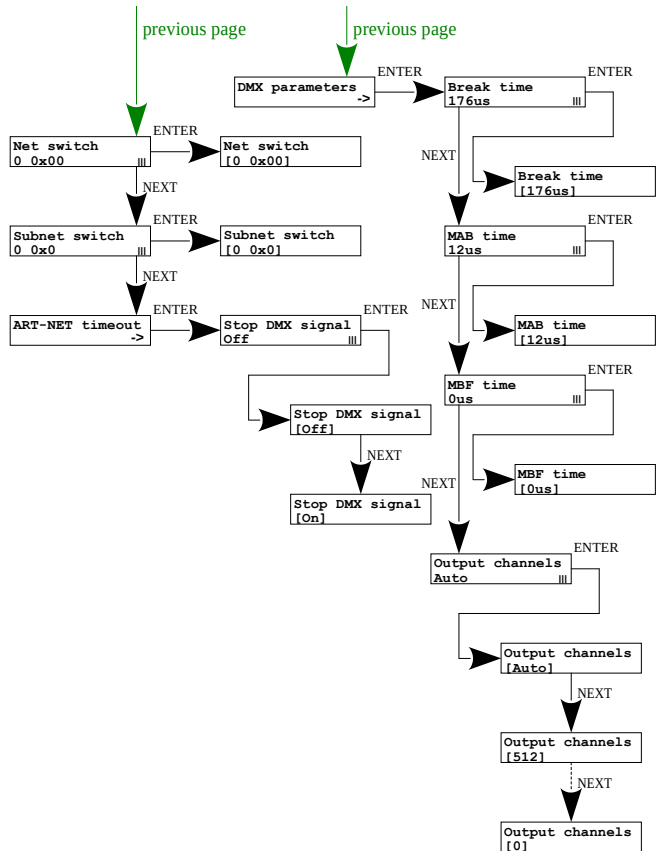

Parameters:

[Port 1 – 4] – individual settings of Art-Net ports

[Universe] – the universe number on which a given port runs. The selectable range is 0 – 32767. The number is displayed in two formats: decimal and hexadecimal. Hexadecimal notation allows you to easily differentiate universe components, for example: **0xNNSU**, where:

- **NN:** (Net switch) network number in the Art-Net protocol (range 0 – 127 dec, 0x0 – 0x7f hex)

- **S:** (Sub-Net switch) sub-net number in the Art-Net protocol (range 0 – 15 dec, 0x0 – 0xf hex)
- **U:** Universe switch

Using **[Universe]** you can change all 3 universe number components (Net switch, Sub-Net switch and Universe switch). There is a possibility of quick preview from the main menu of Universes assigned to a given port, the diagram below:

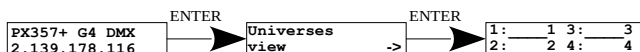

NOTE! A change of a port universe number that entails changing the components Net or Sub-Net will automatically result in a change of the universe of the other ports. This is due to specific nature of the Art-Net protocol addressing, where the gate has a common value for the fields Net and Sub-Net for all the four ports.

[Universe switch] – universe number in the Art-Net protocol (range 0 – 15 dec, 0x0 – 0xf hex). Individual setting of a Universe switch value for a given port. It is a component of the entire Universe number for the port.

[Direction] – setting the direction of signal conversion. Available Art-Net on DMX or DMX on Art-Net.

[Merge mode] – port merging mode setting. Available values of LTP (Latest Takes Precedence) and HTP (Highest Takes Precedence).

[DMX parameters] – configuration of DMX parameters for a given port, times:

- **[Break time]** – duration of a low state along the line at the beginning of DMX packet transmission (range $176\mu\text{s}$ – $352\mu\text{s}$)
- **[MAB time]** – (Mark After Break) – MAB length – interval after the break that is present in each packet according to standard DMX512 (range $12\mu\text{s}$ – $88\mu\text{s}$)
- **[MBF time]** – (Mark Between Frames) – interval between DMX512 frames (channels). MBFs separate stop bits of one channel from the start bits of another channel (range $0\mu\text{s}$ – $76\mu\text{s}$).

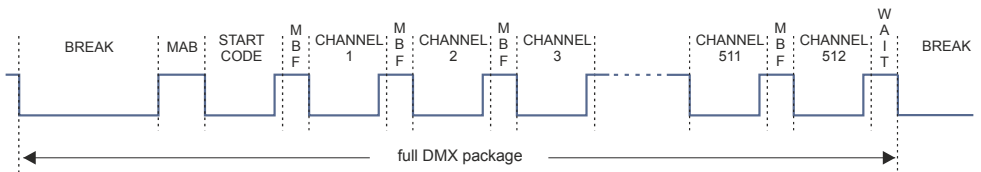

[Output channels] – defines the number of channels sent out through a given port

Settings:

[Auto]: the number of channels in a port is equal to the number of channels received by the Art-Net protocol. You can force transmission of the selected number of channels within the range: 0 – 512.

[Net switch] – setting a network value in the Art-Net protocol. It is a common setting for all the ports. The range is 0 – 127 (0x00 – 0x7f)

[Subnet switch] – setting a sub-network value in the Art-Net protocol. It is a common setting for all the ports. The range is 0 – 15 (0x0 – 0xf)

[Stop DMX signal]

- **[On]**: turns off DMX transmission if Art-Net signal is lost
- **[OFF]**: the ports continue to transmit the last values

4.6 Art-Net configuration in mode DMX → Art-Net

In the PX357+ gate in the mode of converting the signal from DMX512 to Art-Net after the change of **[Direction]** in the chosen port on DMX → Art-Net, the configuration **[DMX parameters]** disappears, and the **[Transmission]** parameter appears in their place, in which options are available:

- **[Unicast]** – transmission, in which exactly one packet is sent to exactly one recipient – there is only one sender and only one recipient. After selecting this option, the recipient's IP address will appear on the screen.
- **[Broadcast]** – transmission mode consisting in sending by one port of packets that should be received by all other ports connected to a given network – one sender and many recipients
- **[Auto]** – the device sends packets only to "interested" devices with given packets. Based on the ArtPoll query and the obtained ArtPollReply response from another device, the PX357+ creates an IP list to send packets.

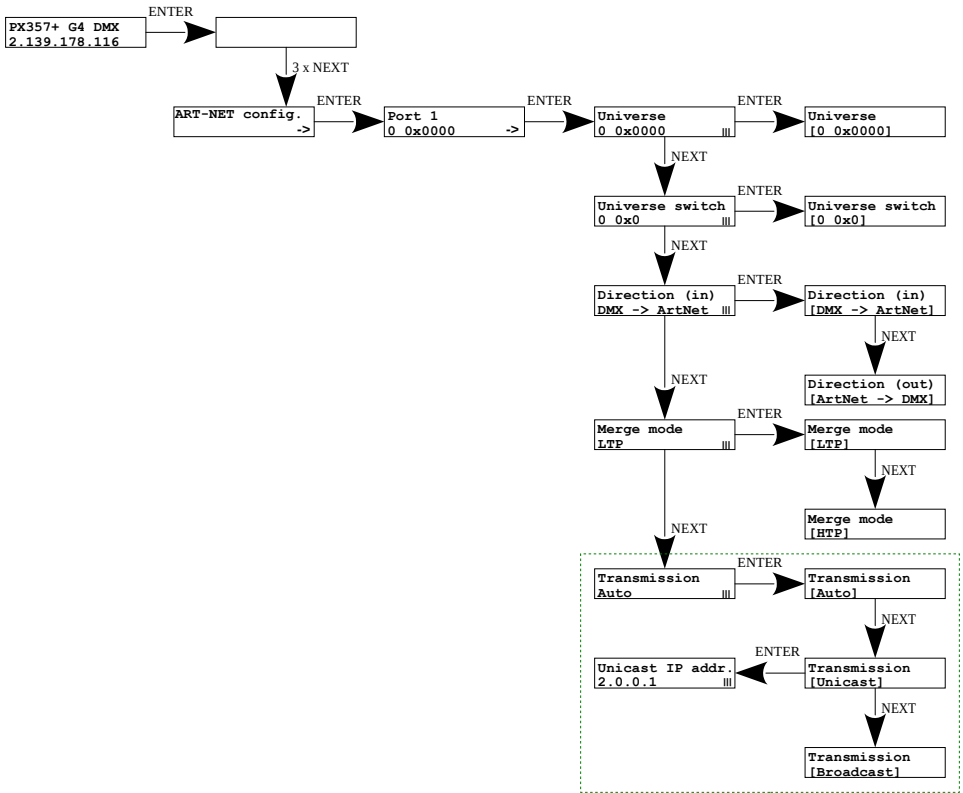

4.7 Presets menu

In the gate are predefined 2 standard sets of factory settings: 2.x.x.x and 10.x.x.x, which additionally have option of changing global direction.

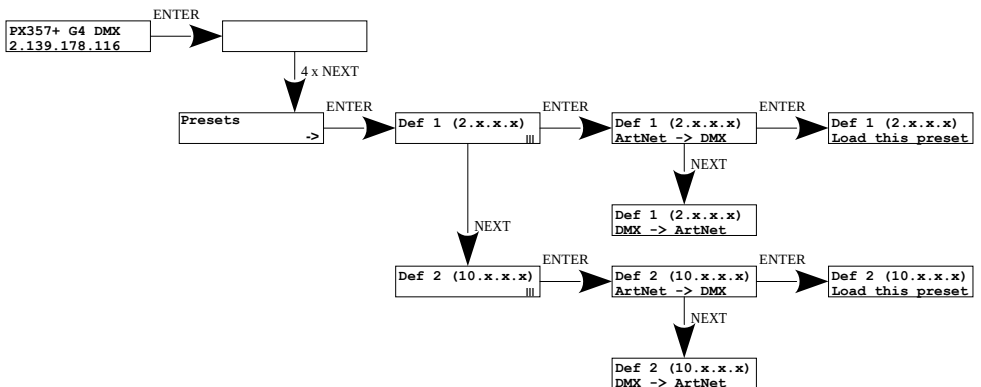

4.8 Settings for the other parameters

The miscellaneous sub-menu **[Miscellaneous]** allows you to turn on **[On]** or off **[Off]** the screen saver **[Screensaver]**. After 15 seconds the display and the all the indicator LEDs will be turned off. The device will continue to operate, without any interruption of the other parameters.

To restore the backlight, press any key.

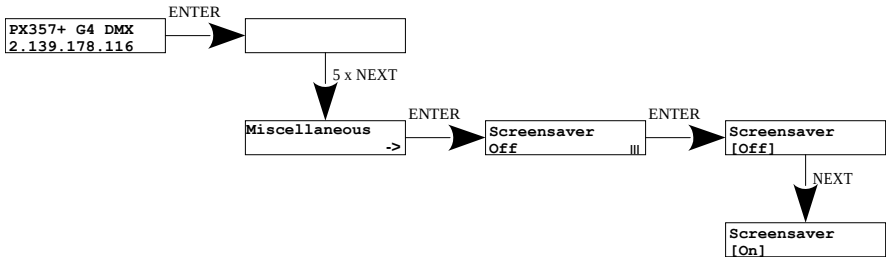

5 Information communicated by LED indicators

The indicator diodes on the front panel of the gate provide information on the status of the unit: The four upper LEDs are bi-color ones (blue – orange) and communicate the status of DMX. Each diode is assigned to one of the four DMX ports.

Action	Function
blinking blue (every ~1s)	DMX transmission through the port concerned
blinking blue (every ~3s)	hold the last value [Stop DMX signal] – [On]
blinking blue (every ~0.5s)	transmission using merging (i.e. output data are a result of combining data from two Art-Net sources)

The above information refers to the so-called normal operating mode.

Additional information communicated by the LED indicators:

- if the screen saver mode is enabled or an “Art-Net Mute Indicators” command has been received, all the diodes **go out**
- if the gate receives an “Art-Net Indicate” command, all the diodes start **blinking**

- if Art-Net packets stop being received by a given port, then, depending on the Art-Net Timeout option:
 - Timeout [**Stop DMX signal**]:
 - if [**Stop DMX signal**] is off [**Off**] the port will continue to send the last values and the diode will continue to **blink in blue**
 - if [**Stop DMX signal**] is on [**On**] transmission through the port will stop and the diode **will go out**

Two single-color diodes at the bottom:

- **the yellow** one communicates receiving or sending a network packet
- **the green** one communicates the status of the Ethernet network, if the diode emits continuous light, the network is connected, if the diode is not emitting light, there is no access to the network

6 Art-Net commands

List of Art-Net commands supported in PX357+

Name	Value
OpPoll	0x2000
OpPollReply	0x2100
OpOutput / OpDmx	0x5000
OpSync	0x5200
OpAddress	0x6000
OpInput	0x7000
OpFirmwareMaster	0xf200
OpFirmwareReply	0xf300

"Art-Net™ Designed by and Copyright Artistic Licence Holdings Ltd"

7 Upgrade

In order to update the gate firmware, use the program DMX-Workshop, which is available on the Artistic Licence website:

<http://www.artisticlicence.com>

Firmware updates are available on the manufacturer's website.



1. In the main menu field select the option **[Node List]**
2. In the field **[Active Art-Net Nodes]** select the device to which you want to upload the update
3. Right-click the device chosen, selecting in this sequence: **[Advanced]→[Programme Upload]→[Firmware]**
4. Using the “magnifying glass” button located to the right of the update access path, download the file with *.*alf* extension
5. In the **[Compatible Devices]** field select again the device to update
6. In order to upload the update, press the button **[Upload new Firmware]**

NOTE! When installing new software, problems may arise due to the Windows® firewall settings. One of the solutions is to completely disable the system firewall for the time of uploading the new firmware version. The second is to add the DMX-Workshop program to the exceptions in the firewall giving all permissions without having to completely disable the firewall (screen on next page).

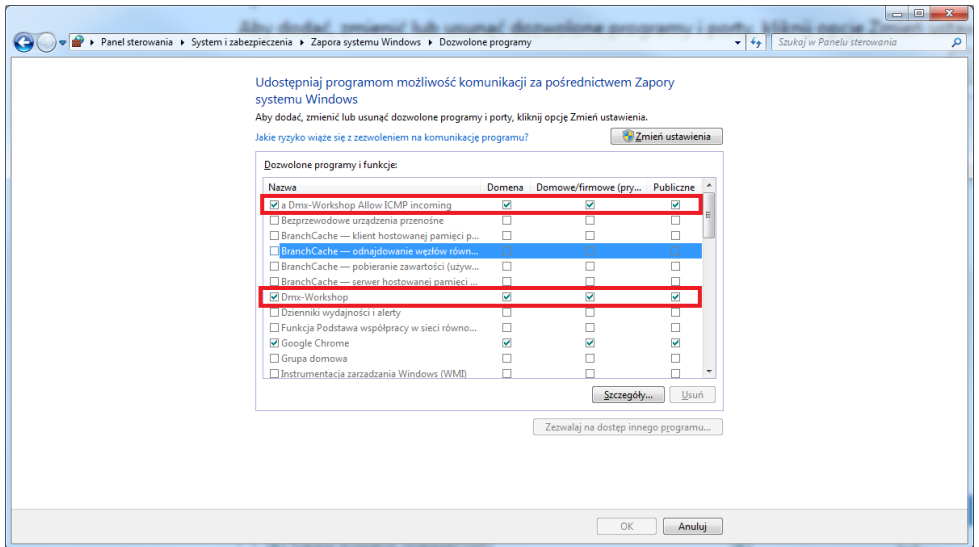

8 Connection scheme

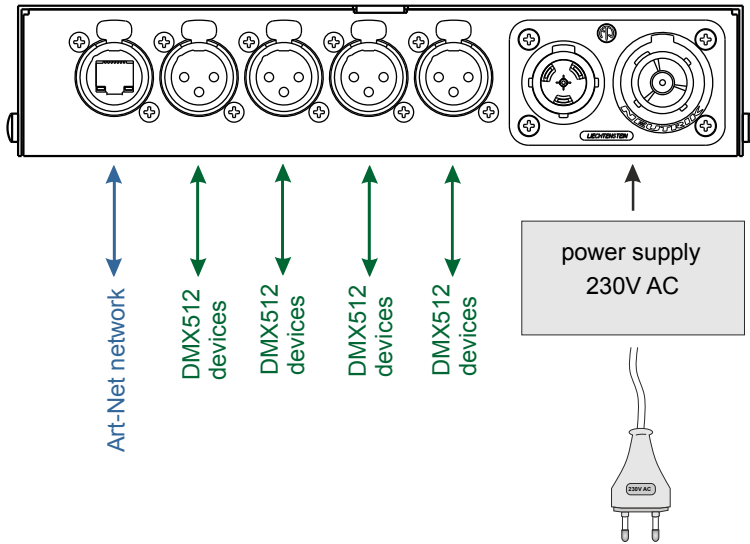

Example of connecting a device operating in DMX512 mode → Art-Net (on the left) and Art-Net → DMX512 (on the right):

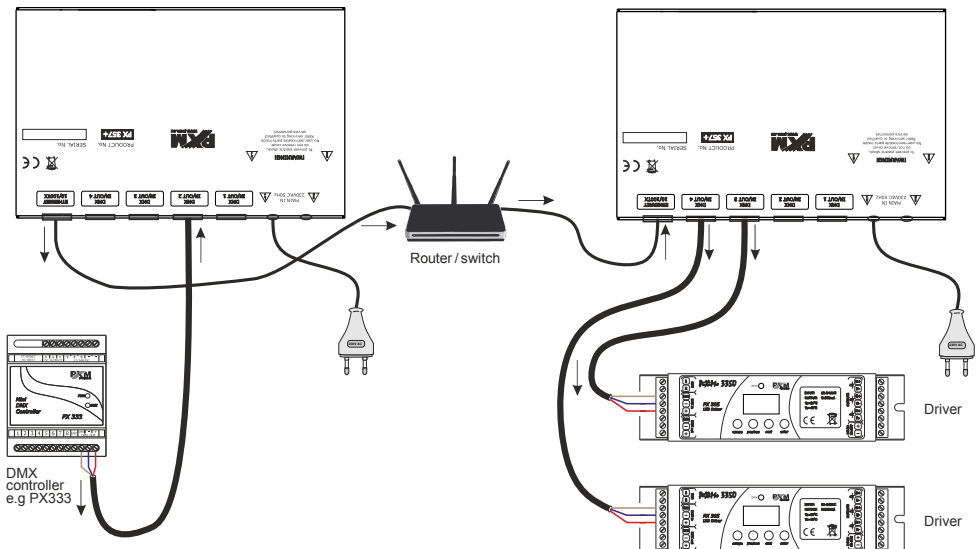

9 Dimensions

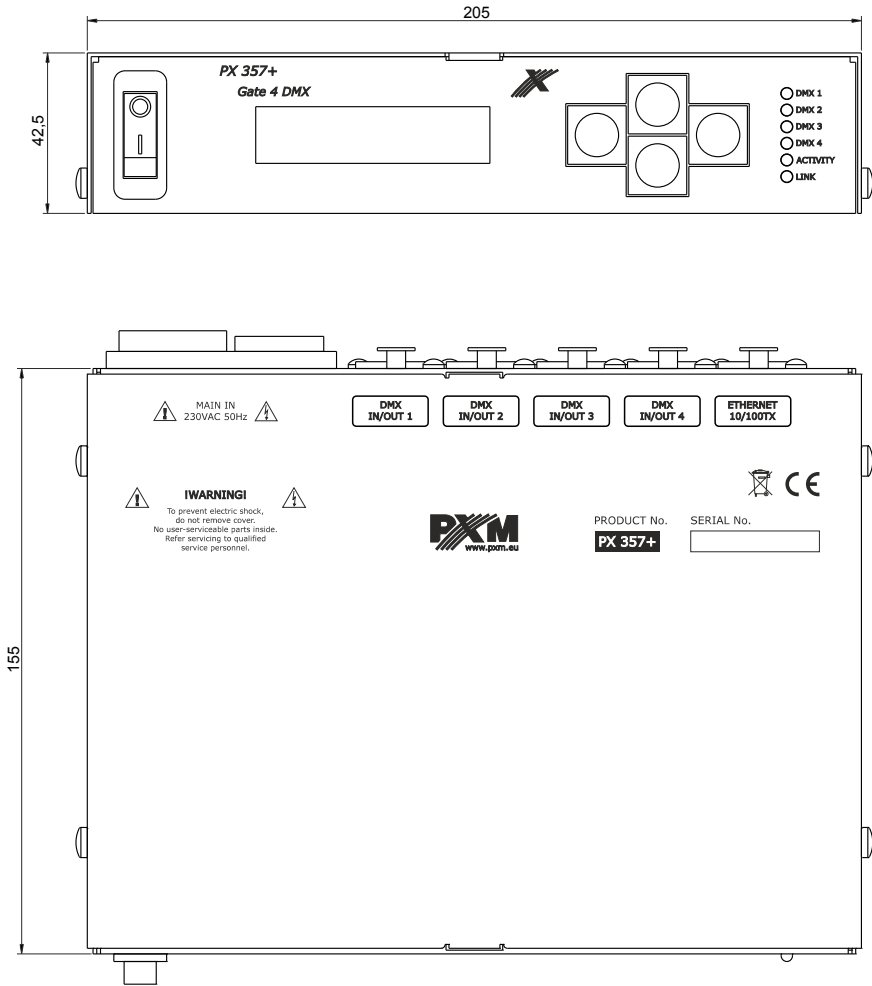

10 Technical data

type	PX357+
DMX lines	4
DMX input	socket 3-pin or 5-pin Neutrik XLR
bi-directional signal conversion	yes
optically isolated XLR connectors	yes
galvanic isolated XLR connectors	yes
Ethernet connector type	Neutrik etherCON
DHCP protocol support	yes
Art-Net version	Art-Net 1, 2, 3, 4
communication method	Art-Net, display and buttons
firmware update	through Art-Net 4 protocol
default user presets	2 (2.x.x.x and 10.x.x.x)
indications mode	Normal, Mute, Identify
“No signal Art-Net” mode	yes (holding last value)
synchronous mode support	yes
dark mode (saver)	yes
user interface	2 x 16 LCD display, 4 x buttons, 6 diodes
power supply	230V AC PowerCON TRUE1 Neutrik
power consumption	8W
weight	1.2kg
dimensions	width: 205mm height: 42,5mm depth: 155mm

DECLARATION OF CONFORMITY

PXM Marek Żupnik spółka komandytowa
Podłęże 654, 32-003 Podłęże

we declare that our product:

Product name: Gate 4 DMX

Product code: PX357+

meets the requirements of the following standards, as well as harmonised standards:

PN-EN IEC 63000:2019-01	EN IEC 63000:2018
PN-EN IEC 62368-1:2020-11	EN IEC 62368-1:2020
PN-EN 61000-4-2:2011	EN 61000-4-2:2009
PN-EN IEC 61000-6-1:2019-03	EN IEC 61000-6-1:2019
PN-EN IEC 61000-6-3:2021-08	EN IEC 61000-6-3:2021

and meets the essential requirements of the following directives:

2011/65/UE **DIRECTIVE OF THE EUROPEAN PARLIAMENT AND OF THE COUNCIL** of 8 June 2011 on the restriction of the use of certain hazardous substances in electrical and electronic equipment
Text with EEA relevance.

2014/30/UE **DIRECTIVE OF THE EUROPEAN PARLIAMENT AND OF THE COUNCIL** of 26 February 2014 on the harmonisation of the laws of the Member States relating to electromagnetic compatibility (recast)
Text with EEA relevance.

2014/35/UE **DIRECTIVE OF THE EUROPEAN PARLIAMENT AND OF THE COUNCIL** of 26 February 2014 on the harmonisation of the laws of the Member States relating to the making available on the market of electrical equipment designed for use within certain voltage limits

Marek Żupnik spółka komandytowa
32-003 Podłęże, Podłęże 654
NIP 677-002-54-53



mgr inż. Marek Żupnik.