

PX342

Driver LED C.V.

1 x 10A

User manual



# Table of Contents

1 Description.....	3
2 Safety conditions.....	3
3 Connectors and control elements.....	4
4 Smooth function.....	5
5 DMX address setting.....	6
6 LED indicators.....	7
7 DMX signal connecting.....	7
8 Connection scheme.....	8
9 Dimensions.....	10
10 Technical data.....	10

*Manufacturer reserves the right to make modifications in order to improve device operation.*

PXM Marek Żupnik sp.k.  
Podłęże 654  
32-003 Podłęże  
BDO register number 000005972

tel. +48 12 385 83 06  
mail: [info@pxm.pl](mailto:info@pxm.pl)  
[www.pxm.pl](http://www.pxm.pl)

Rev.1-2  
01.07.2020

# 1 Description

---

Driver LED C.V. 1 x 10A is a device used to control one PWM output channel with a maximum load of 10A using the DMX512 signal.

Setting the DMX address and the activation of the *Smooth* function is possible by using *DIP Switch* control. In addition to controlling LED stripes, PX342 can also be used to control the speed of DC motors using the DMX512 protocol.

The device is equipped with DMX signal input and output. PX342 is produced in a plastic housing adapted for mounting on a 35mm DIN rail.

## 2 Safety conditions

---

PX342 is a device powered with safe voltage 12 – 24V DC; however, during installation and use the following rules must be strictly observed:

1. The device may only be connected to 12 – 24V DC with current-carrying capacity compatible with technical data.
2. All the conductors should be protected against mechanical and thermal damage.
3. In the event of damaging any conductor, it should be replaced with a conductor of the same technical data.
4. Only a shielded cable should be used to connect the DMX signal.
5. All repairs and connections of outputs or DMX signal can only be made with cut off power supply.

6. PX342 should be strictly protected against contact with water and other liquids.
7. All sudden shocks, particularly dropping, should be avoided.
8. The device cannot be turned on in places with humidity exceeding 90%.
9. The device cannot be used in places with temperature lower than +2°C or higher than +40°C.
10. Clean with damp duster only.

### 3 Connectors and control elements

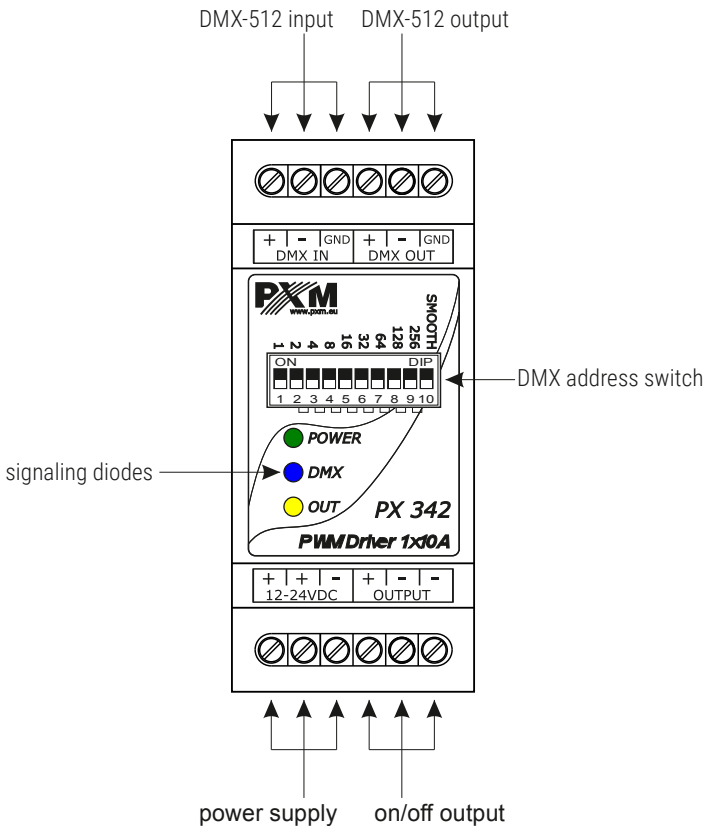

# 4 Smooth function

---

PX342 is equipped with a useful *Smooth* function. It is activated by changing the position 10 of the *DIP Switch* to the *ON* position.



This makes it possible to smooth DMX values with rapid changes. This option eliminates the phenomenon of "light vibrations".

The *Smooth* function takes up the next DMX address after being set to *DIP Switch*. If the device's DMX address is set to 1, then *Smooth* support will be on address 2.

The smoothing procedure is performed linearly. The user can change the time in which the transition between successive DMX values will occur. For the DMX value of 0, the smoothing time is 0s, while for the value of 255 this time is ~2s.

When DC motors are connected and controlled, the *Smooth* function allows to set the speed (time at which it reaches the set speed) of acceleration and deceleration of the motor.

# 5 DMX address setting

PX342 allows for setting the DMX address. The address is set in a binary code using the *DIP Switch*. Below are some examples of setting the DMX address. The first 9 switches are responsible for the DMX address, switch 10 is responsible for activating the *Smooth* function.

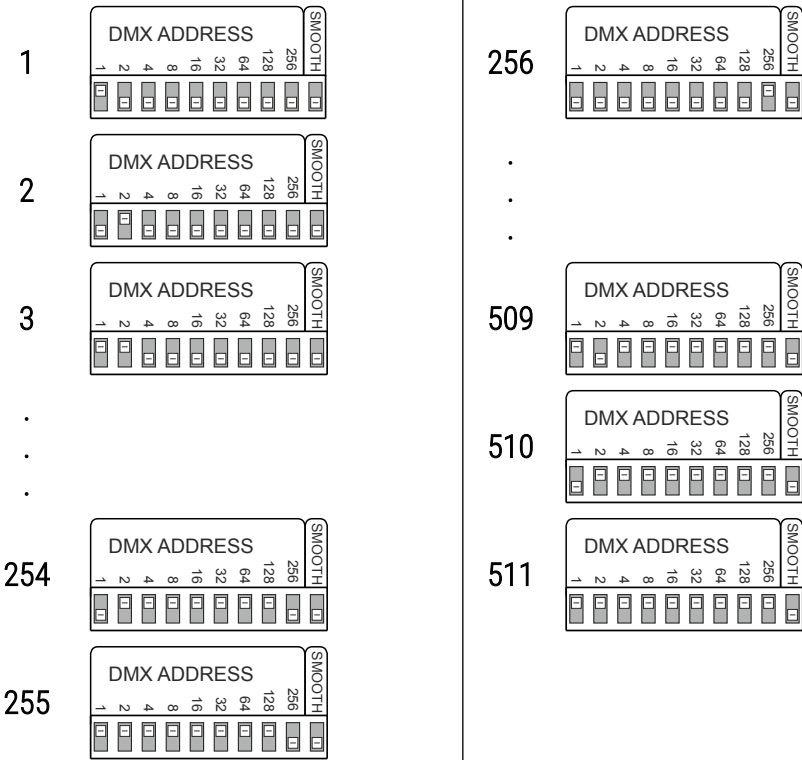
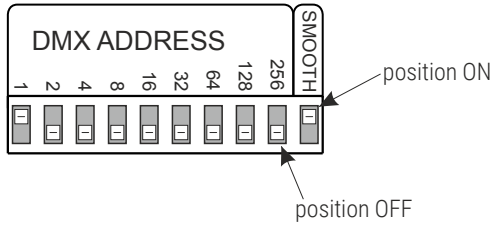

## 6 LED indicators

The driver is equipped with 3 indicator lights:

Indicator	Action	Function
green ● <i>Power</i>	permanent light	the device is working properly
blue ● <i>DMX</i>	flashes	receiving DMX signal
yellow ● <i>Out</i>	smooth brightening / dimming	mapping of the channel control

## 7 DMX signal connecting

PX324 have to be connected to DMX line in serial mode, with no branches on DMX control cable. That means that DMX line, from the signal source, must be connected to **DMX IN** pins of PX342 and later, directly from **DMX OUT** pins to the next device in DMX chain.

If the PX342 is the last DMX chain receiver there should be terminator (resistor 120 Ohm) mounted between “+” and “-” pins of **DMX OUT** section.

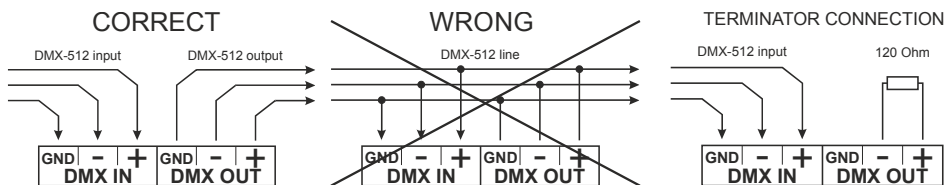

# 8 Connection scheme

## Connecting the LED strip

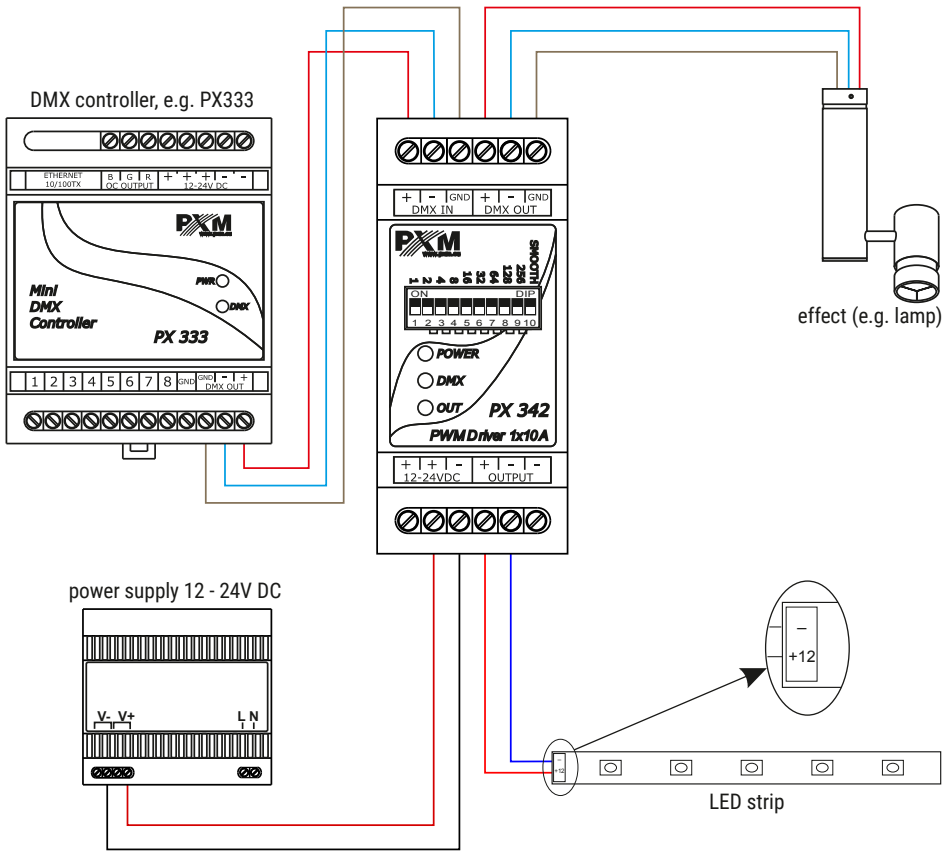



# DC motor connection

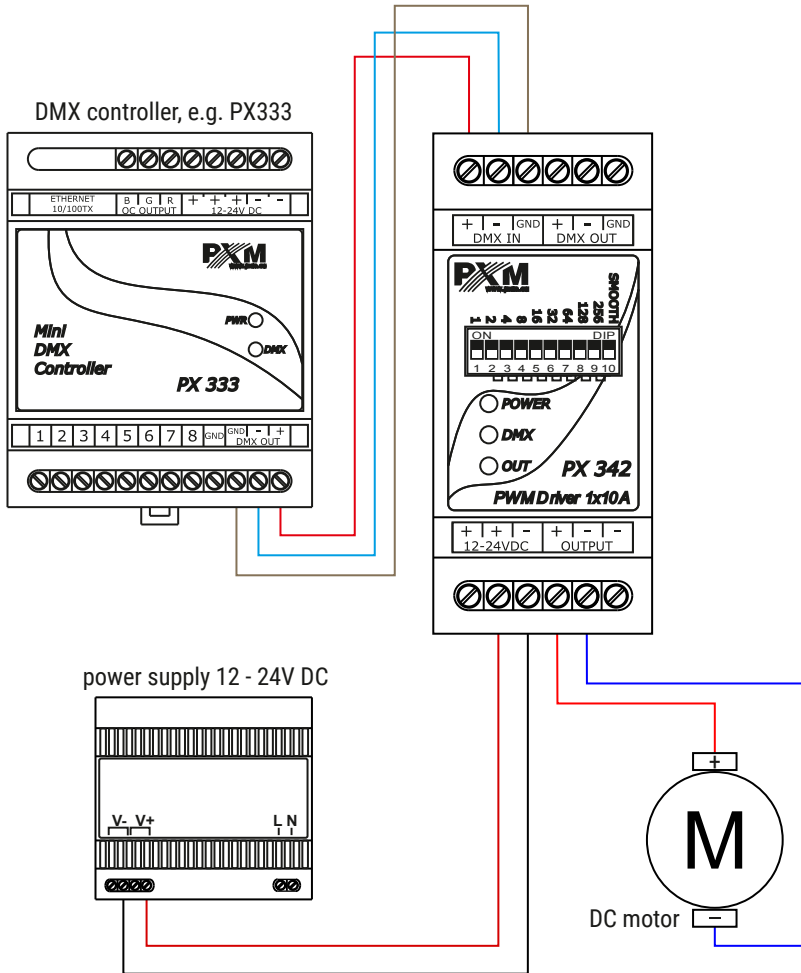

## 9 Dimensions

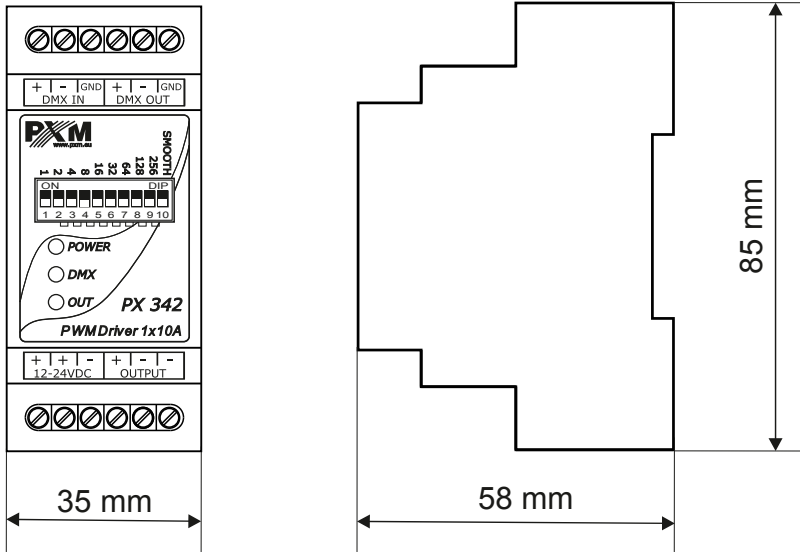

## 10 Technical data

type	PX342
DMX channels	511
number of output channels	1
power supply	12 – 24V DC
output current carrying capacity	max. 10A
no load power consumption	max. 0.1W
output sockets	screw connectors
weight	0.1kg
dimensions	width: 35mm height: 85mm depth: 58mm

## DECLARATION OF CONFORMITY

PXM Marek Żupnik spółka komandytowa  
Podłęże 654, 32-003 Podłęże

we declare that our product:

*Product name:* Driver LED C.V. 1 x 10A

*Product code:* PX342

meets the requirements of the following standards, as well as harmonised standards:

PN-EN IEC 63000:2019-01	EN IEC 63000:2018
PN-EN 62368-1:2015-03	EN 62368-1:2014
PN-EN 61000-4-2:2011	EN 61000-4-2:2009
PN-EN IEC 61000-6-1:2019-03	EN IEC 61000-6-1:2019
PN-EN 61000-6-3:2008	EN 61000-6-3:2007

and meets the essential requirements of the following directives:

2011/65/UE **DIRECTIVE OF THE EUROPEAN PARLIAMENT AND OF THE COUNCIL** of 8 June 2011 on the restriction of the use of certain hazardous substances in electrical and electronic equipment  
Text with EEA relevance.

2014/30/UE **DIRECTIVE OF THE EUROPEAN PARLIAMENT AND OF THE COUNCIL** of 26 February 2014 on the harmonisation of the laws of the Member States relating to electromagnetic compatibility (recast)  
Text with EEA relevance.

2014/35/UE **DIRECTIVE OF THE EUROPEAN PARLIAMENT AND OF THE COUNCIL** of 26 February 2014 on the harmonisation of the laws of the Member States relating to the making available on the market of electrical equipment designed for use within certain voltage limits

  
**Marek Żupnik** spółka komandytowa  
32-003 Podłęże, Podłęże 654  
NIP 677-002-54-53



mgr inż. Marek Żupnik.