

PX319-HV

Driver LED
1x1,5A/60V

MANUAL



TABLE OF CONTENTS

1. General description.....	3
2. Safety conditions.....	3
3. Connections and control elements description.....	4
4. DMX indicator light meanings.....	4
5. DMX address setting.....	5
5.1 Smooth function settings.....	6
5.2. No Signal function settings.....	6
5.3. PWM frequency settings.....	6
6. Driver output current setting.....	7
6.1 Temperature control.....	8
7. Connection diagram.....	9
8. Technical drawing.....	10
9. Technical data.....	10
Declaration of conformity.....	11

Manufacturer reserves the right to make modifications in order to improve device operation.

Ver. 1.0

PXM Marek Żupnik spółka komandytowa
Podłęże 654
32-003 Podłęże

tel.: 12 626 46 92
fax: 12 626 46 94
E-mail: info@pxm.pl
Internet: www.pxm.pl

1. GENERAL DESCRIPTION

The PX319-HV driver is designed to control LEDs. It has voltage of 12 - 60 V DC and a maximum current-carrying capacity of 1,5 A. It is possible to set the driver output current according to the parameters of receivers LED.

PX319-HV can be controlled by the DMX signal (the device has a built-in DMX 512 receiver) or it can work independently. DMX address is set manually via a DIP switch on the housing. The user also has the ability to set one of the eight levels of brightness with which the LEDs will be triggered in the absence of a DMX signal.

2. SAFETY CONDITIONS

PX319-HV is a device powered with safe voltage of 12 - 60 V DC; however, you should at all times obey the safety conditions. It is necessary to observe the following rules:

1. The device can be connected to 12 - 60 V DC (stabilised voltage) with current-carrying capacity compatible with technical data.
2. All the conductors should be protected against mechanical and thermal damage.
3. In case of damage to a conductor, it should be replaced with a conductor of the same technical parameters.
4. Connection of DMX signal can be made with a shielded conductor only.
5. All repairs, connecting and disconnecting of cables can only be made with cut off power supply.
6. The device should be strictly protected against contact with water and other liquids.
7. All sudden shocks, particularly dropping, should be avoided.
8. The device cannot be turned on in places with humidity exceeding 90%.
9. The device cannot be used in places with temperature lower than +2°C or higher than +40°C.
10. Clean with damp cloth only.

3. DESCRIPTION OF THE JOINTS AND CONTROLS

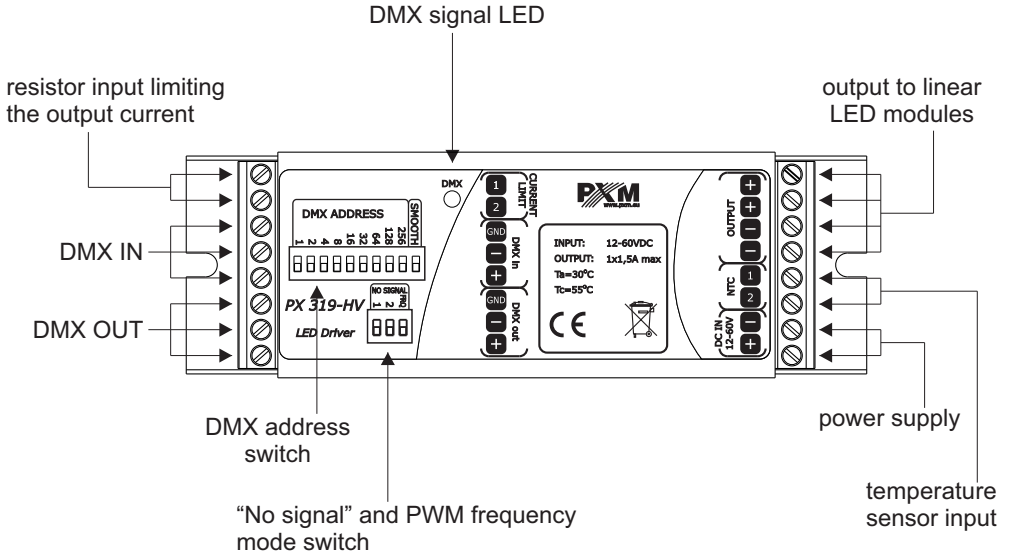

4. DMX INDICATOR LIGHT MEANINGS

The driver is equipped with one indicator light:

Status	Function
the diode is emitting constant light	“No Signal” mode operation, the driver is not receiving any DMX signal
the diode is blinking	a DMX signal is being received

4. DMX ADDRESS SETTING

PX319-HV allows for setting the address DMX. The address is set in a binary code using the "DIP switch". Below are some examples of setting the address DMX. Nine first "DIP switches" are responsible for the address; the tenth switch is responsible for activating the "smooth" function.

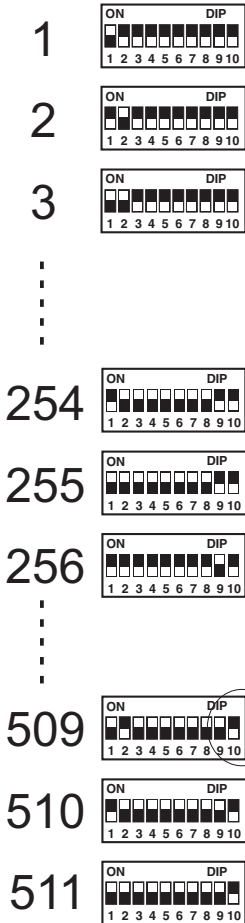

The white colour is a switch. It is ON when set in the upper position, and OFF when set in the lower position.

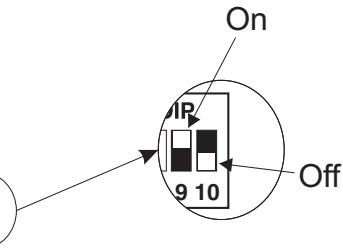

4.1. SMOOTH FUNCTION SETTINGS



The “smooth” function and DMX address set to 1.

With the smooth function enabled, transitions between successive control signal values are smoothed, allowing for smooth changes in the brightness of the connected LEDs. This prevents the light “vibration” effect that usually occurs in lighting systems when light intensity is being changed.

4.2. NO SIGNAL FUNCTION SETTINGS

The PX319-HV driver is equipped with an additional DIP-Switch which allows you to set the No Signal function, responding to the driver action when it does not receive the DMX signal.

With this switch, it is possible to set one of 4 brightness levels. The brightness increases from the smallest (zero) to the maximum one, in accordance with the binary markings on the “DIP switch”. Below are brightness levels and the corresponding switch settings.

0  Zero brightness level

1  1 brightness level

2  2 brightness level

3  3 brightness level

5.3. PWM FREQUENCY SETTINGS

You can set PWM frequencies using individual switch position no. 3 on the DIP switch:



Zero brightness level and PWM frequency of 366 Hz



Zero brightness level and PWM frequency of >20 kHz

5. DRIVER OUTPUT CURRENT SETTING

The PX319-HV driver is equipped with a function to set the output current controlling linear LED modules. Depending on the number of modules connected to the device, it is necessary to select the control current by choosing a resistor with the appropriate resistance. The table below shows the correct selection of resistors:

Current limit	Resistor
250 mA	100R
300 mA	270R
350 mA	470R
400 mA	680R
500 mA	910R
600 mA	1k2
700 mA	1k5
750 mA	1k8
800 mA	2k2
900 mA	2k4
1000 mA	3k
1050 mA	3k3
1100 mA	3k9
1250 mA	4k7
1300 mA	5k1
1400 mA	6k2
1500 mA	7k5

In the absence of any connection between resistor and PX319-HV driver, it will operate with adjusted 250 mA output current (as for 100 Ohm resistor connection).

Below is the table allowing for the selection of resistor barcodes:

Color	Significant figures	Multiplier	Tolerance	Temperature coefficient
None	-	-	20%	Irrelevant
Silver	-	x0,01	10%	
Gold	-	x0,1	5%	
Black	0	x1	-	
Brown	1	x10	1%	
Red	2	x100	2%	
Orange	3	x1000	-	
Yellow	4	x10.000	-	
Green	5	x100.000	0.50%	
Blue	6	x1000.000	0.25%	
Purple	7	x10.000.000	0.10%	
Grey	8	x100.000.000	-	
White	9	x1000.000.000	-	

Example of the resistor identification:

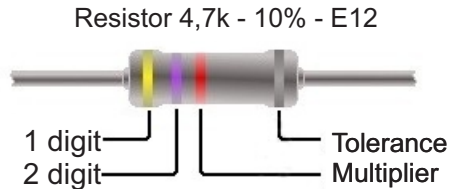

6.1. TEMPERATURE CONTROL

You can connect an external 4K7 thermistor to the driver. As the temperature exceeds 70°C, the driver starts to limit output power. Once a 90°C threshold is exceeded, complete shut off is carried out.

If no NTC thermistor has been connected:

100% of power available at the output

NTC thermistor short circuit:

0% of power available at the output

6. CONNECTION DIAGRAM

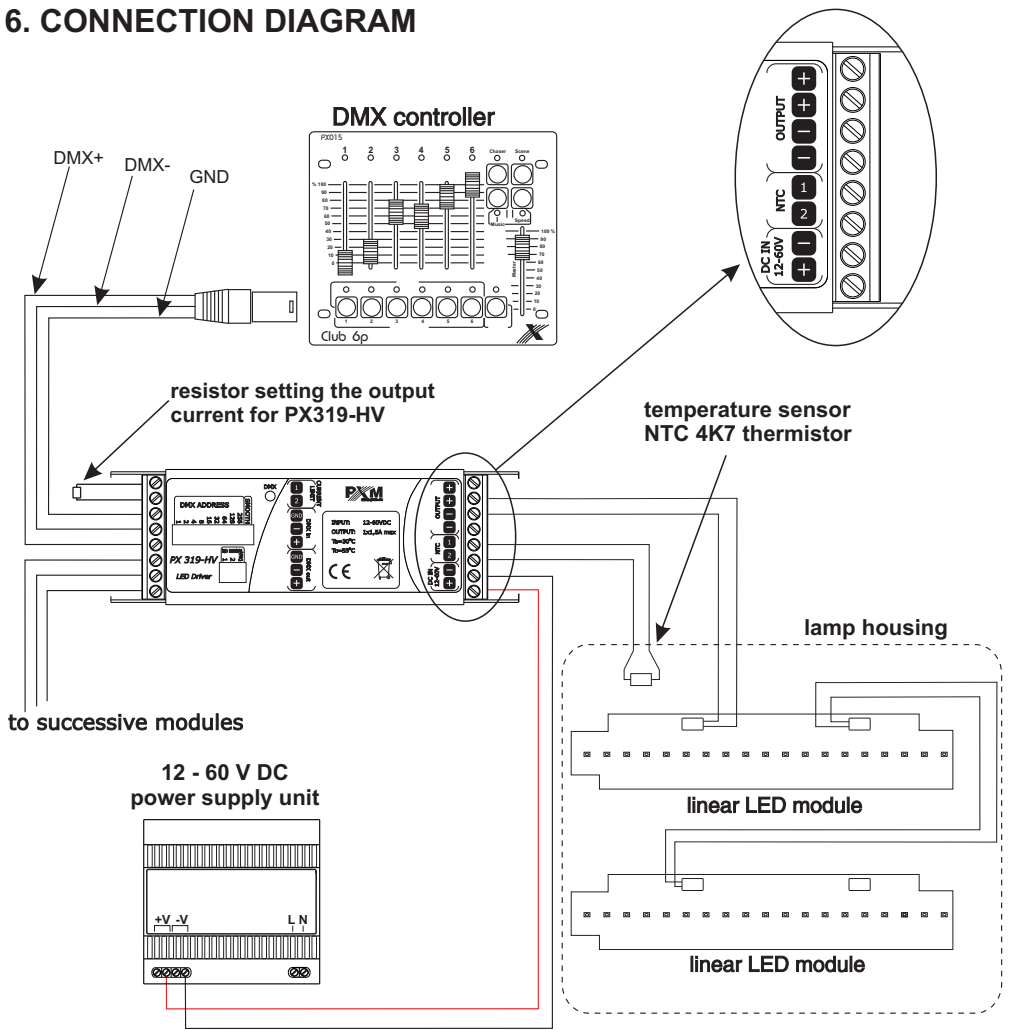

PX319-HV must be connected to DMX line in series. This means that DMX IN terminals in the device must be provided with the driving cable, and then from DMX OUT connector the driving cable must be provided to other DMX receivers.

If PX319-HV is the last device in DMX line, DMX Out terminals must be provided with the terminator – resistor of 120 Ohm between pins “+” and “-”.

CORRECT

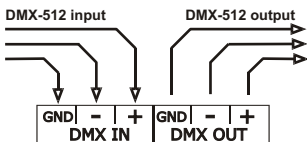

INCORRECT

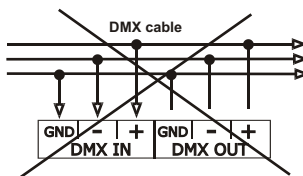

120 Ohm

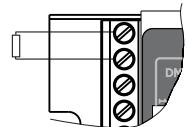

7. TECHNICAL DRAWING

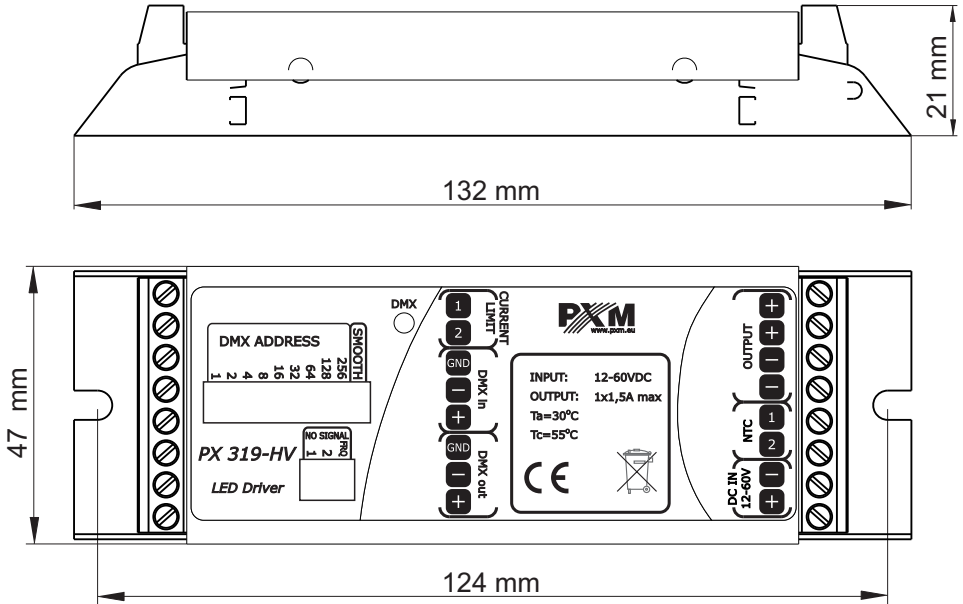

8. TECHNICAL SPECIFICATION

- DMX channels:	511
- Output channels number:	1
- Power supply:	12 - 60 V DC
- Maximum current consumption:	1,5 A
- Power consumption without load:	0,5 W
- Scene brightness:	8
- Output load:	250 - 1500 mA
- Output sockets:	screw terminals
- Weight:	0,14 kg
- Dimensions:	
Width	132 mm
Height	47 mm
Length	21 mm





Podłężę 654
32-003 Podłężę

tel: 012 626 46 92
fax: 012 626 46 94

e-mail: info@pxm.pl
http://www.pxm.pl

DECLARATION OF CONFORMITY

PXM Marek Żupnik spółka komandytowa
Podłężę 654, 32-003 Podłężę

We declare that our product::

Product name: **Driver LED 1x1,5A/60V**

Product code: **PX319HV**

meets the requirements of the following standards as well as harmonised standards:

PN-EN 50581:2013,	EN 50581:2012
PN-EN 61000-4-2:2011,	EN 61000-4-2:2009
PN-EN 61000-6-1:2008,	EN 61000-6-1:2007
PN-EN 61000-6-2:2008,	EN 61000-6-2:2005

and meets the essential requirements of the following directives:

2011/65/UE DIRECTIVE OF THE EUROPEAN PARLIAMENT AND OF THE COUNCIL of 8 June 2011 on the restriction on the use of certain hazardous substances in electrical and electronic equipment.

2014/30/UE DIRECTIVE OF THE EUROPEAN PARLIAMENT AND OF THE COUNCIL of 26 February 2014 on the harmonisation of the laws of the Member States relating to electromagnetic compatibility and repealing Directive 2004/108/EC.



Marek Żupnik spółka komandytowa
32-003 Podłężę, Podłężę 654
NIP 677-002-54-53

Podłężę, 24.11.2016

mgr inż. Marek Żupnik.