



Device description

PxGround 12 is a LED lamp designed for dynamic lighting of architectural details.

The PX318 lamp uses high-performance OSRAM Oslon LEDs. They are divided into three groups. The product has built-in a baffle against the unpleasant glare effect. It slightly reduces the beam angle of output light, but gives the opportunity to use the lamps in installations where light quality and all the accompanying phenomena must be at the highest quality.

Another advantage of the PX318 is the ability to change the angle of the LED module inclination inside the lamp without moving the entire lamp housing. This allows to change independently the luminous flux direction (to within $\pm 10^\circ$) to the mounted housing.

The lamp is using efficient LEDs that provide a variety of color options and allow to achieve different brightness levels. The device is manufactured in versions with colors of emitted light such as: cold white, neutral white, warm white and RGB. In addition, universal design makes it possible to be used to illuminate the historic architecture, as well as in modern buildings. Maximum power consumption of the lamp is 30W. Each of the PX318 version can be fitted with optics of light distribution angles of 6, 14, 28 or 47°.

The lamp requires a 24V DC power supply, the control can be done using voltage drivers such as PX254 or PX282. Finally, the product is equipped with a LEDs power-limiting circuit depending on temperature. This solution allows for long-life and trouble-free operation of the product. After reaching a temperature of 55°C it starts to reduce the current supplied to the LEDs and at a temperature of 80°C they are totally switched off.

Technical drawing

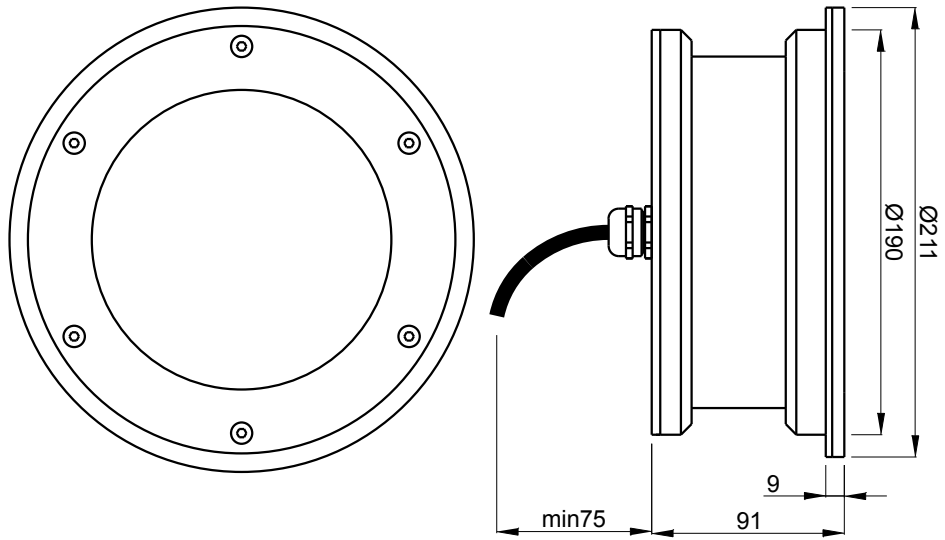

Connection diagram

Example of connection with PX254 driver

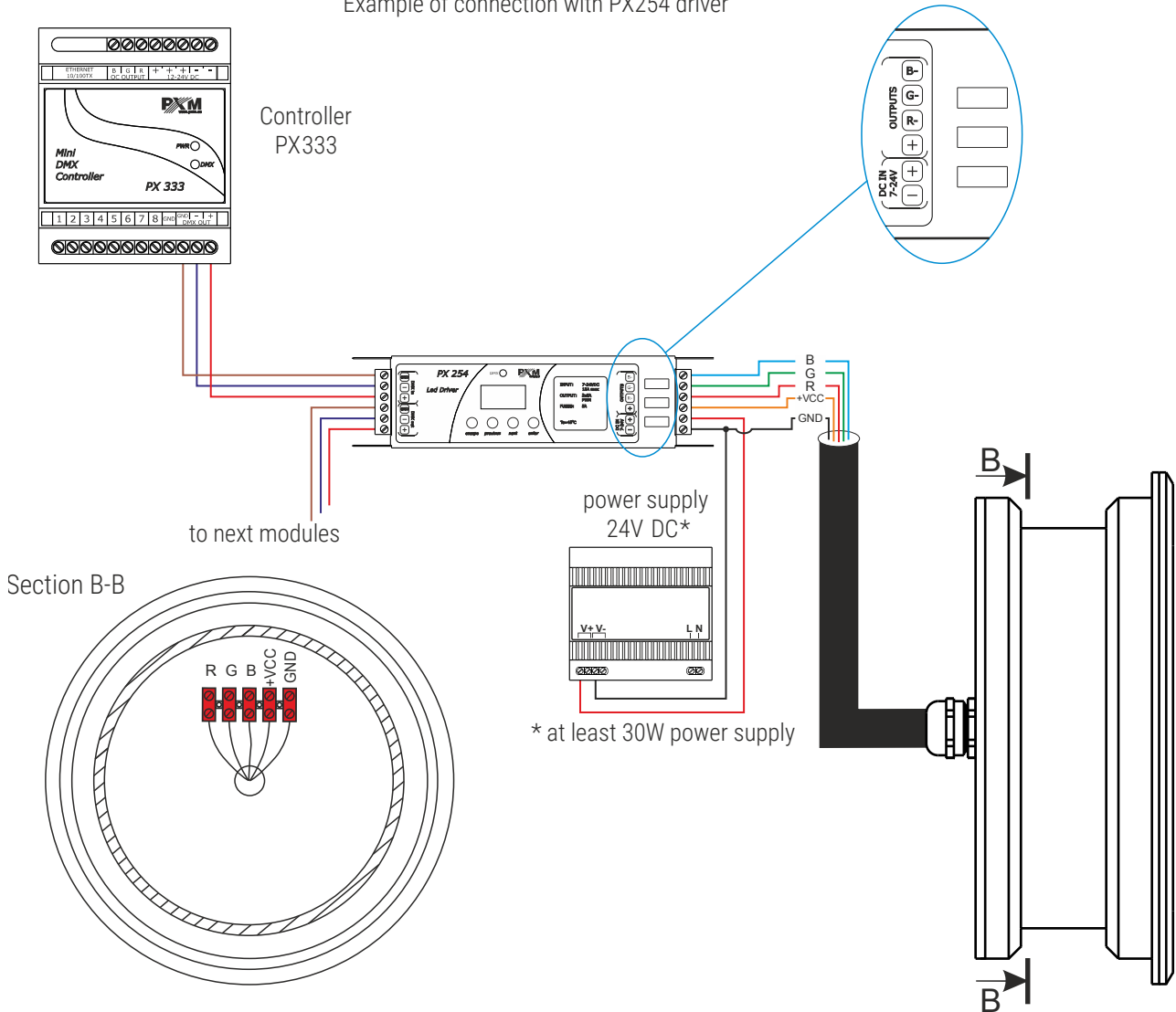

Technical data

type	PX318
power supply	24V DC
power consumption	30W
control	voltage drivers, e.g. PX254, PX282
number of LEDs	12
light beam angle	6°, 14°, 28°, 47°
LEDs colors	RGB, WNC
CRI (for the WNC version)	min. 80
IP rating	IP67
housing material	acid-proof stainless steel (316L)
weight	6.7kg
dimensions	diameter: 211mm height: 91mm