

PX308

*PiXiMo*  
3350

LED Driver  
3 x 350 mA  
48V DC

MANUAL



# CONTENTS

1. General description.....	3
2. Safety conditions.....	3
3. Connections and control elements description.....	4
4. Displayed messages and their meaning.....	4
5. Dmx address setting.....	5
6. Master / slave feature.....	6
7. White balance.....	7
8. Colours' mode.....	7
9. Individual settings.....	8
10. Reaction to dmx signal interruption.....	9
11. Programs' description.....	10
12. Temperature limitations.....	11
13. Er0 error message.....	12
14. Brightness control frequency.....	12
15. Display blanking.....	12
16. Smooth.....	13
17. Default settings and memory error (Err).....	13
18. Display reversing feature.....	14
19. Programming.....	15
20. Connection scheme.....	16
21. Dimensions.....	17
22. Technical specification.....	17
23. Declaration of conformity.....	18

*The manufacturer reserves the right to make changes in the functioning and operation of the controller, in order to improve the product.*

Rev 1.0

*PXM Marek Żupnik spółka komandytowa  
ul. Przemysłowa 12  
30-701 Kraków, Poland*

*tel.: +48 12 626 46 92  
fax: +48 12 626 46 94  
E-mail: [info@pxm.pl](mailto:info@pxm.pl)  
Internet: [www.pxm.pl](http://www.pxm.pl)*

# 1. GENERAL DESCRIPTION

The PX308 driver is designed to control LEDs. The device has been placed inside metal housing. The built-in DMX receiver allows for activating 3 channels (R, G, B) by using directly the DMX protocol. A wide range of supply voltage and a high level of current-carrying capacity enable activating large quantities of LEDs.

PX308 can be controlled by the DMX signal or it can work independently.

In this operation mode, the user has access to a fully programmable stage and 18 default sequences for which he can also change the reproduction speed and the smoothness of transition of particular steps. With the use of 16-bit resolution, controlling the parameters of channels is completely smooth. Moreover, the driver offers an effect control mode which allows for controlling the programs that are built into the device and, at the same time, changing such parameters as speed, brightness and fade settings using the DMX-512 signal sent from an external controller.

The driver offers a built-in control signal frequency tuning system ("flicker free" technology), which makes it useful in applications for the television industry. As LEDs from the RGB series often differ in parameters, problems in receiving white colour may occur (triggering 100% at all channels). This is why the PX308 has been equipped with a very useful feature called 'white balance.' With this feature, each set of LEDs can be adjusted so that the control of individual colours by the module enables achieving white colour at full activation.

What is more, this feature allows for adjusting colour temperature of white.

PX308 has also been equipped with a function of temperature power output limit and connectors for connecting a temperature sensor.

# 2. SAFETY CONDITIONS

PX308 LED Driver 3 x 350 mA is a device powered with safe voltage up to 48V; however, you should at all times obey the rules set forth below::

1. The device may be connected to 24 - 48V DC (stabilized voltage) with current-carrying capacity compatible with technical data only.
2. All the conductors should be protected against mechanical and thermal damage.
3. In the event of damaging any conductor, it should be replaced with a conductor of the same technical parameters.
4. Connection of DMX signal can be made with shielded conductor only.
5. All repairs and connections of outputs or DMX signal can only be made with cut off power supply.
6. PX308 should be strictly protected against contact with water and other liquids.
7. All sudden shocks, particularly dropping, should be avoided.
8. The device cannot be turned on in places with humidity exceeding 90%.
9. The device cannot be used in places with temperature lower than 2°C or higher than 40°C.
10. Clean with damp duster only.

### 3. CONNECTIONS AND CONTROL ELEMENTS DESCRIPTION

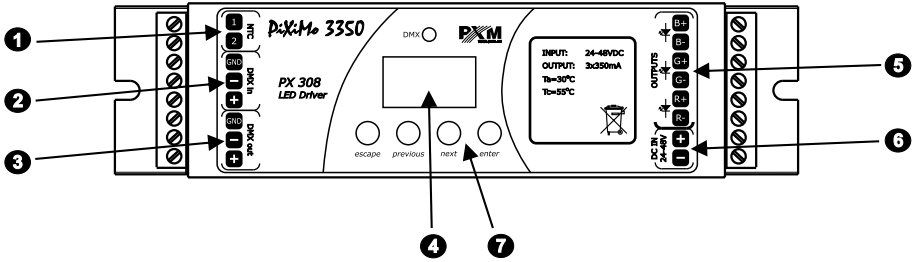

- ❶ Temperature sensor input
- ❷ DMX-512 input
- ❸ DMX-512 output
- ❹ Display
- ❺ Control output
- ❻ Power supply
- ❼ Control buttons

### 4. DISPLAYED MESSAGES AND THEIR MEANING

- 000.** driver's DMX address - the basic *menu* state
- ALL.** setting the parameters for all channels concurrently
- 1nB.** setting the parameters individually for each channel
- ABE.** DMX address setting
- EBn.** control mode settings (RGB or BRIGHTNESS / COLOUR)
- nB5.** reaction on DMX signal interruption
- EBB.** MASTER / SLAVE mode settings
- 2BB.** operation in BRIGHTNESS / COLOUR mode
- 3BB.** operation in RGB mode
- 4BB.** operation in RGB Dimmer mode
- HSL.** operation in HSL - HUE/SATURATION/LIGHTNESS
- 0nB.** turning all the outputs on at 100%
- 0FF.** turning all the outputs off
- 5nB.** scene
- EPD.** message showing no temp. sensor connection to PX308 with function **ENP.** active

<b>P07</b>	program no. 17
<b>A01</b>	setting the address of the first channel
<b>E0A</b>	turning ON/OFF of MASTER mode
<b>CHM</b>	emitted channels number in the MASTER mode
<b>BAW</b>	white balance settings
<b>BRP</b>	red colour balance
<b>BGG</b>	green colour balance
<b>BLB</b>	blue colour balance
<b>BCA</b>	turning the white balance on / off
<b>SPD</b>	program playing speed
<b>FAD</b>	program step-to-step fading smoothness
<b>RED</b>	red colour setting during scene programming
<b>GRN</b>	green colour setting during scene programming
<b>BLU</b>	blue colour setting during scene programming
<b>FBA</b>	base frequency brightness control
<b>SCP</b>	screen saver and DMX signal LED blanking
<b>EPA</b>	memory error message
<b>DFD</b>	restore default device settings menu
<b>SEH</b>	function of smoothing the transitions between different values
<b>DDS</b>	smooth option turn off
<b>P2P</b>	packet to packet smoothing menu
<b>E0N</b>	time smoothing menu
<b>E0N</b>	power limit based on temperature
<b>BLB</b>	temperature value from which power output limitation is activated
<b>BHA</b>	temperature value for which device outputs are completely deactivated
<b>EPC</b>	current temperature value

## 5. DMX ADDRESS SETTING

The PX308 module's menu allows to set the device's DMX address in a range from 1 to 510. The module takes up 3 subsequent DMX addresses, when set to 510, last channel has 512 address.

To set the DMX address:

1. Select Adr menu.
2. With "next" or "previous" buttons set the required DMX address.

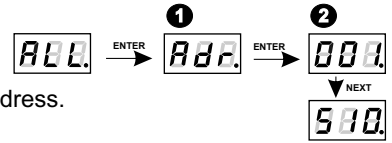

## 6. MASTER / SLAVE FEATURE

The PX308 driver is equipped with DMX-512 signal receiver and can be controlled with any DMX desktop. In addition, the unit has a built-in programmable reaction to DMX signal interruption (noS). By dint of 18 factory-defined programs you can obtain interesting effects without the external controller. In case of using few PX308 in the complex installations realizing the same sequence cannot guarantee the full playing synchronization. That is why the driver is provided with the MASTER feature. When this feature is active, the module becomes the DMX signal transmitter and sends to all the other modules (set as SLAVES, DMX signal receivers) the realized program. Thanks to such a solution the precise synchronization, even in very complex installations, is possible.

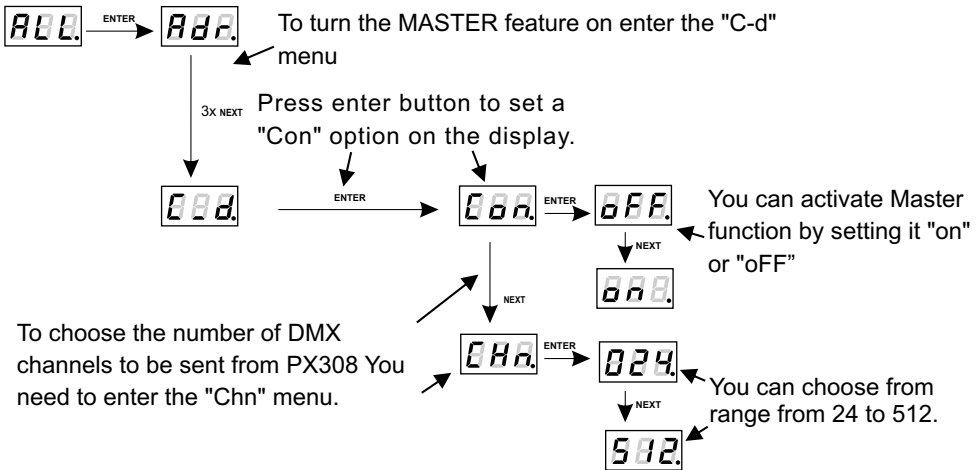

### CAUTION:

PX308 basically sends three channels (R, G, B), but because the DMX standard defines the minimal emitted channels number as 24, these three channels are duplicated eight times. If there is such a necessity, you can multiply them up to 512 channels (this setting is not recommended because of the decrease of a transmission speed).

## 7. WHITE BALANCE

Achieving the white colour on RGB LEDs in many cases may be a problem. It can be caused by applying diodes of different technical specification. For that reason the PX308 driver is provided with the white balance feature. With this feature you can set the right colour temperature for full control of all three outputs (to reach true white colour). The maximal value (100) is set by default, the temperature can be adjusted by reducing it to a required level (to 50 maximum).

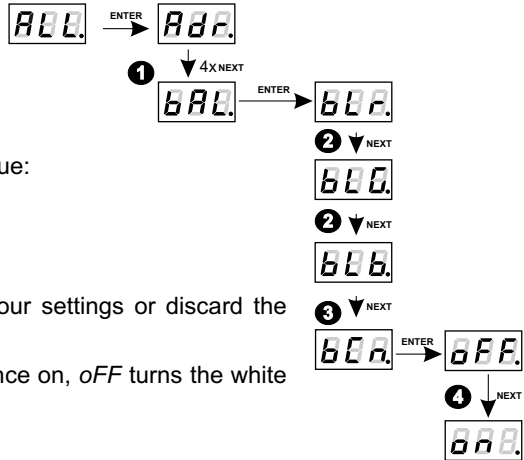

To set the white balance:

1. Enter the *bAL* feature.
2. For each channel set the required value:
  - bALr* - for the red channel,
  - bALg* - for the green channel,
  - bALb* - for the blue channel.
3. Enter the *bCn* menu, to confirm your settings or discard the adjusted values.
4. The *on* setting turns the white balance on, *oFF* turns the white balance feature off.

## 8. COLOURS' MODE

PX308 can operate in HSL, 4-channel, 3-channel and 2-channel mode. The HSL mode operates on 3 channels, each channel regulates in turn: hue, saturation and lightness. 4-channel (3bd) mode adjusts the colours separately (red, green and blue) and on the 4th channel the Dimmer (all outputs' dimming) feature is implemented. In the 3-channel (3-byte) mode each of RGB colours is adjusted separately and in the 2-channel (2-byte) mode one channel sets the brightness and the second selects one of the 256 factory-defined colours.

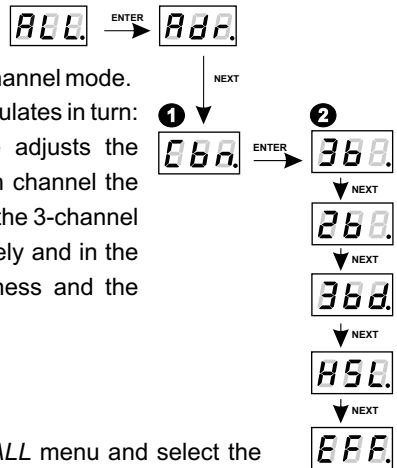

To set the colours mode, enter the *Cbn* feature in the *ALL* menu and select the required colours mode: 2b for 2-byte mode, 3b for 3-byte mode, 3bd for RGBDimmer mode or HSL for Hue/Saturation/Lightness. There is also EFF mode - description on next site.

After setting the mode selected in the individual settings menu (see Para. 9) number of editable channels will be limited in accordance with the selected mode (e.g. in 2b-2byte mode to two channels).

Description of *EFF* mode - effect mode.

EFF mode (effect) settings						
CHANNEL 1 RED	CHANNEL 2 GREEN	CHANNEL 3 BLUE	CHANNEL 4 – TRYB	CHANNEL 5 SPEED	CHANNEL 6 FADE	CHANNEL 7 BRIGHTN.
-	-	-	< 0 - 7 > Program1	x	x	x
-	-	-	< 8 - 15 > Program2	x	x	x
-	-	-	< 16 - 23 > Program3	x	x	x
-	-	-	< 24 - 31 > Program4	x	x	x
-	-	-	< 32 - 39 > Program5	x	x	x
-	-	-	< 40 - 47 > Program6	x	x	x
-	-	-	< 48 - 55 > Program7	x	x	x
-	-	-	< 56 - 63 > Program8	x	x	x
-	-	-	< 64 - 71 > Program9	x	x	x
-	-	-	< 72 - 79 > Program10	x	x	x
-	-	-	< 80 - 87 > Program11	x	x	x
-	-	-	< 88 - 95 > Program12	x	x	x
-	-	-	< 96 - 103 > Program13	x	x	x
-	-	-	< 104 - 111 > Program14	x	x	x
-	-	-	< 112 - 119 > Program15	x	x	x
-	-	-	< 120 - 127 > Program16	x	x	x
-	-	-	< 128 - 135 > Program17	x	x	x
-	-	-	< 136 - 143 > Program18	x	x	x
-	-	-	< 144 - 151 > OFF	-	-	-
x	x	x	< 152 - 169 > Strobo 10%	x	-	x
x	x	x	< 170 - 199 > Strobo 20%	x	-	x
x	x	x	< 200 - 229 > Strobo 50%	x	-	x
x	x	x	< 230 - 255 > RRGBD	-	-	x

CHANNEL 1 - red colour

CHANNEL 2 - green colour

CHANNEL 3 - blue colour

CHANNEL 4 - work mode change channel

CHANNEL 5 - speed settings (greater value - bigger speed)

CHANNEL 6 - fade settings (greater value - smoother change)

CHANNEL 7 - brightness settings (greater value - brighter light)

(„x“) sign - shows the ability to control the parameter of the selected mode

(„-“) sign - shows the lack of ability to control the parameter of the selected mode

## 9. INDIVIDUAL SETTINGS

The PX308 driver has the individual settings option. It allows to ascribe a discretional DMX address to every output channel. The simplest example of this is controlling the one-coloured LEDs brightness connected to all of the outputs. In such a case you need to ascribe one DMX address to all the channels and thanks to this all the outputs can be controlled with for example one slider only on the control desk.



If you select the **[C b n]** operating mode in the menu, which limits the number of channels in relation to the maximum value, you can not program individually address that are out of range of selected mode. For example, when you select **[2 b 2]** mode only address 1 and 2 can be individually assign the selected value. For the rest from **[Ad 3]** to **[Ad 7]** the unit displays a **[000]** message that the address is out of range mode.

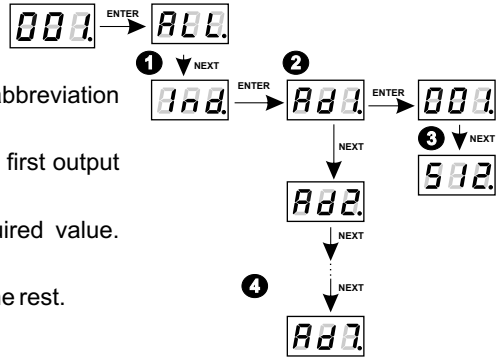

To define the individual settings:

1. Enter the individual settings menu (the Ind abbreviation stands for this menu).
2. With "next" or "previous" buttons choose the first output settings (Ad1).
3. With "next" or "previous" key set the required value. You can choose from range from 1 to 512.
4. Set the addresses for the second output and the rest.

## 10. REACTION TO DMX SIGNAL INTERRUPTION

This feature is used not only to protect the installation from DMX signal interruption, but also to control the LEDs without the external controller. After the feature is activated, when the DMX signal is not present, the module will realize the selected function independently. When the DMX signal is connected again, the module stops playing the function and starts working according to the commands transmitted through the DMX line.

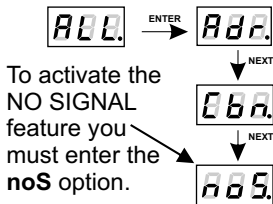

To activate the NO SIGNAL feature you must enter the **noS** option.

You can also use one of the 18 factory-defined sequences. You may adjust the playing speed and step-to-step fading smoothness for each program.

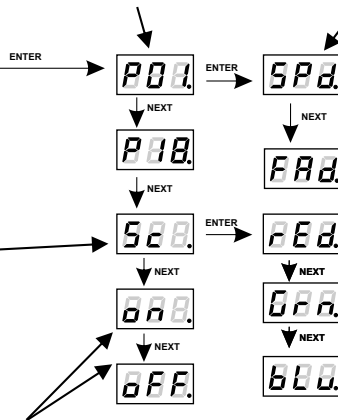

To define the scenes by your own you must enter the **Sc** option.

To adjust the program's steps fading speed in one of the sequences press "enter" button. Using the "next" or "previous" button set the **FAd** parameter and press "enter". Adjust the fading speed from 0 (immediate step-to-step change) to 100 (change completely smooth) with "next" or "previous" button. Confirm your settings by pressing "enter".

The **red** denotation is for the red channel.  
 The **Grn** denotation is for the green channel.  
 The **bLu** denotation is for the blue channel.  
 The intensity of each colour is adjusted in a range from 0 to 255.

**on** stands for turning all the outputs on at 100 %, **oFF** turns all the outputs off.

**[FAd]** feature - description on next page

Feature **FAd** - to adjust the program's steps fading speed in one of the sequences press "enter" button. Using the "next" or "previous" button set the **FAd** parameter and press "enter". Adjust the fading speed from 0 (immediate step-to-step change) to 100 (change completely smooth) with "next" or "previous" button. Confirm your settings by pressing "enter".

## 11. PROGRAMS' DESCRIPTION

Tables below show values for particular output channels - R, G, B - in programs from 1 to 18 (P01 - P18). 255 stands for maximal output brightness, 127 for 50% and 0 for channel blackout.

		P01	P02	P03	P04	P05	P06	P07	P08	P09	P10
krok 1	R	255	0	0	0	255	255	0	255	0	255
	G	0	0	0	0	0	0	255	0	255	0
	B	0	255	0	0	0	0	255	0	0	0
krok 2	R	0	0	255	0	255	255	255	0	0	0
	G	255	255	0	0	255	0	0	255	0	0
	B	0	0	0	255	0	255	255	0	255	255
krok 3	R	0	255	0	0	0	0	255			
	G	0	0	0	0	255	0	255			
	B	255	0	0	0	0	255	0			
krok 4	R			0	0	0	0				
	G			255	255	255	255				
	B			0	0	255	255				
krok 5	R			0	0	0	0				
	G			0	0	0	255				
	B			0	0	255	0				
krok 6	R			0	255	255	255				
	G			0	0	0	255				
	B			255	0	255	0				

		P11	P12	P13	P14	P15	P16	P17	P18
krok 1	R	0	0	0	255	0	0	0	0
	G	0	0	0	0	255	0	127	0
	B	0	0	0	0	0	255	255	0
krok 2	R	255	0	0	255	127	127	127	255
	G	0	255	0	127	255	0	255	255
	B	0	0	255	0	0	255	127	255
krok 3	R				255	0	0	255	
	G				0	255	0	127	
	B				0	0	255	0	
krok 4	R				255	0	0	127	
	G				0	255	127	0	
	B				127	127	255	127	

## 12. TEMPERATURE LIMITATIONS

PX308 has a built-in feature to reduce outputs power depending on the temperature value read from the sensor mounted in the lamp. This allows you to program the temperature beyond which, power limitation of outputs will start to work or the connected lamp will be switched off completely. The product is designed to work only with the NTC thermistor 4K7.

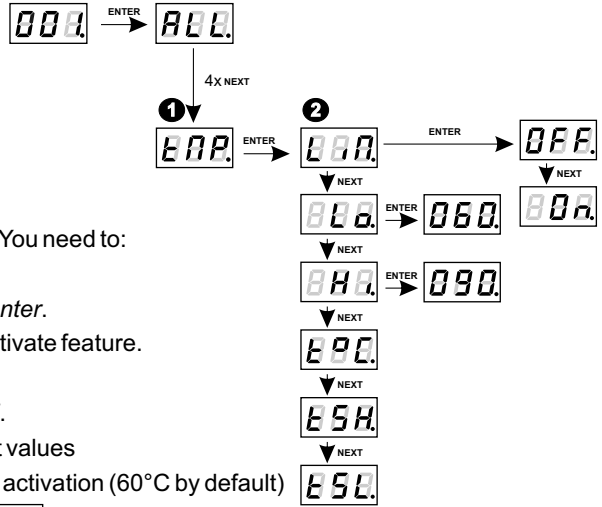

To activate the temperature limitations You need to:

1. Set **E0P** option in menu.
2. Confirm your selection by pressing *enter*.
3. Using the *next* button set **000** to activate feature.

Confirm by pressing *enter*.

By default this option is turned off.

4. Similarly, you can change the default values for **E5L** temperature of function activation (60°C by default) and the maximum temperature **E5H** (90°C by default).

In the **E0C** submenu you can check the current temperature being read from the connected sensor. Submenus **E5H** and **E5L** let you preview the following order: the highest and lowest temperature recorded by the sensor.

The value **E5L** of the activation temperature can be set in the range from 30°C to 60°C. On the other hand, the maximum temperature limit value in the range of 70-90°C.

Chart describing this work of this option is shown below.

Course power limitation between values **E5L** and **E5H** is linearly as shown in the graph below.

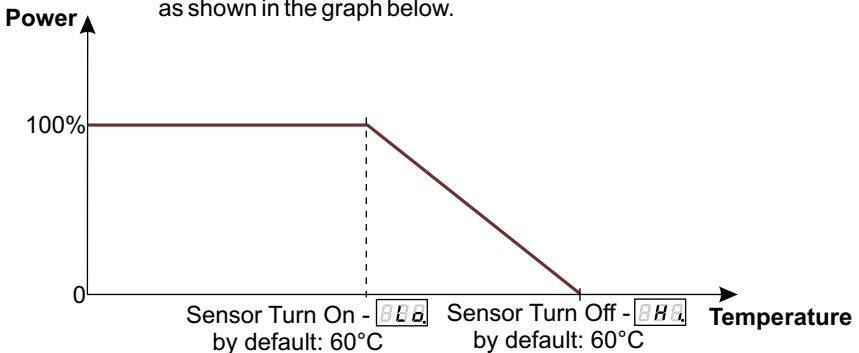

## 13. Er0 ERROR MESSAGE

In case of not connecting to the PX308 any temperature sensor and the simultaneous activation of the limit temperature (after setting **80n** option in the submenu **LEn**) the driver displays a message **Er0**, you that there is no temperature sensor. This information appears in the main menu instead of starting address DMX channel, and in the same time connected to outputs of the PX308 LEDs are turned off.

To disable this message, connect the temperature sensor or disable the temperature limit feature.

## 14. BRIGHTNESS CONTROL FREQUENCY

The "Frq" option allows to set the base frequency control for LEDs. This feature is especially useful in applications for the television industry. Thanks to use of "flicker free" technology it allows to avoid unpleasant flicker effect caused by lack of proper synchronization between signal and LEDs.

The user can choose the frequency in range from 366 Hz to 1.5 kHz, which can be smoothly change using *previous* and *next* buttons to set expected value.

The frequency in the upper range (e.g. value 1.50 = 1.5 kHz) allows to avoid flicker effect visible cameras.

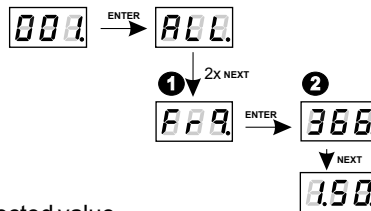

To set the selected frequency range:

1. Set the *Frq* feature.
2. Use *next* or *previous* buttons to set the selected value.

## 15. DISPLAY BLANKING

The device is equipped with the ability to disable backlight of display and operating LED of DMX signal status. This option enables the "SCr" menu. When it is activated, display and LED will switch off after 25 seconds (when no one in the same time will not press of any buttons of the PX308). Of course, the device continues to work without interfering with the other set parameters.

To restore the backlight, use any button.

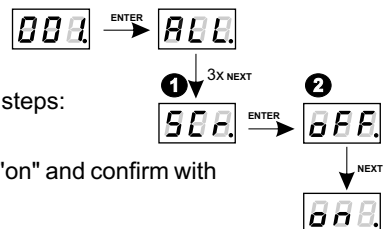

To activate the backlight blanking function follow those steps:

1. Set the SCr and confirm by pressing enter.
2. Using the next or previous buttons change value to "on" and confirm with enter button.

Similarly, you must follow in order to disable this feature, but then instead of "on" in second step, by selecting "oFF".

## 16. SMOOTH

In addition, the driver is equipped with smooth option. It allows smooth changes in brightness and color of connected LEDs. When running the option transitions between successive DMX values sent to the lamp (e.g. corresponding to the brightness changes) occur smoothly, with no visible breaks what prevents common for lighting "flickering" effects. Two consecutive DMX values sent to the end devices are smoothed linearly between packets of DMX signal for selected **P2P** option or within the time interval set in **E80** submenu.

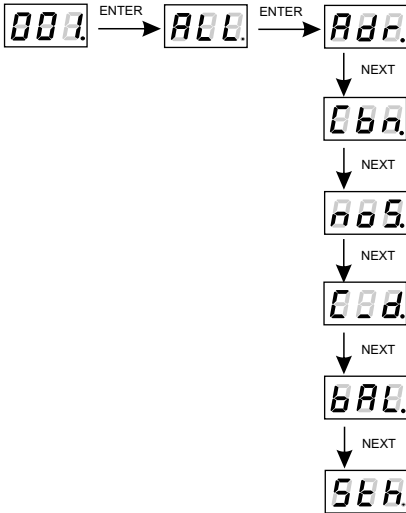

Smoothing function in some cases may slightly slow down the rate of the reaction of end devices (e.g. lamps) to changes of the DMX signal. That is why you can disable this option. To turn off Smooth, select a **d85** parameter and confirm the selection by pressing enter.

Time smoothing **E80** enables changing the time parameter in which subsequent, different values of the DMX signal sent to the lamp are smoothed between each other. The minimum value is 10 [ms] and the maximum is 999 [ms].

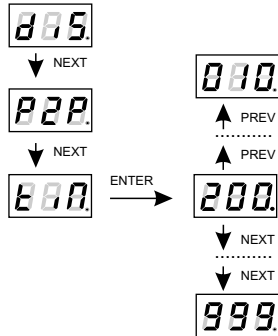

## 17. DEFAULT SETTINGS AND MEMORY ERROR (Err)

The device has a feature that allows for restoring default settings.

To use this option, PX308 must be disconnected from the power supply. Before restoring the power, press and hold the *previous* button. After turning the device on, the **dF1** message will appear on the screen (when turning on the power until displaying the previous **dF1** message, the *previous* button have to be pressed).

This menu designation restores default settings. Accepting this message by pressing the *enter* key restores default settings. It is also possible to exit this menu without returning to default settings by pressing the *escape* button.

The default settings in PX308 are as follows:

- DMX address - 1,
- driver operating mode - RGB (3b - 3-byte),
- master mode - off,
- number of sent DMX channels - 128,
- white balance - off
- no signal operating mode - Program 1
- smoothing function (smooth) - off
- temperature limitation - off

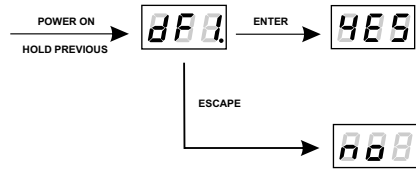

## Err message - memory error

The device is equipped with a built-in memory work control function.

If there are problems with the memory operation on the PX308 display, the **ERR** message appears - memory error.

In this situation, select the *enter* button. The device will reload the default configuration and upload it to the memory. If after this operation, the **ERR** message remains on the screen, the memory is permanently damaged and the unit must be sent to the service point.

There is also a different message informing about an error - **ERRD**.

If this message is displayed, connect the temperature sensor (see diagram on page 16) or turn off the temperature limitation function (see section 12 on page 11).

## 18. DISPLAY REVERSING FEATURE

The driver should be installed (if possible) in a close distance from the controlled LEDs, but the lack of space can result in the need to set it "upside down".

In such case, the displayed messages may become unreadable, which admittedly does not affect the operation of the device, but makes it difficult to program. Therefore PX308 has a feature that allows reversing 180 degrees the screen and change the order of programming buttons.

To activate this function, You need simultaneously press and hold for 3 seconds the two middle keys of the device (PREVIOUS and NEXT).

The figure below shows the action of the active display reversing feature.

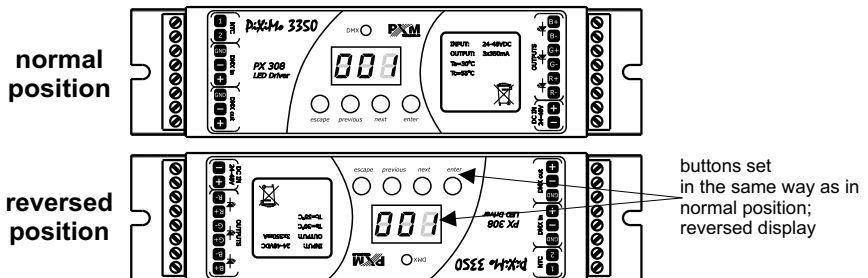



## 20. CONNECTION SCHEME

Due to use of passive-type DMX in the PX308 driver, a terminator is needed at the end of DMX line. Such a solution allows to connect up to 32 of the PX308 drivers to a DMX controller (serial connection).

The connections have to be made with wires of appropriate gauge. The proper connection lowers the risk of damaging the driver and improves its reliability. For DMX signal connection use the shielded conductors only.

**CAUTION:** In case of voltage loss on one of the modules in a chain, this one and the subsequent modules will not respond to a DMX signal.

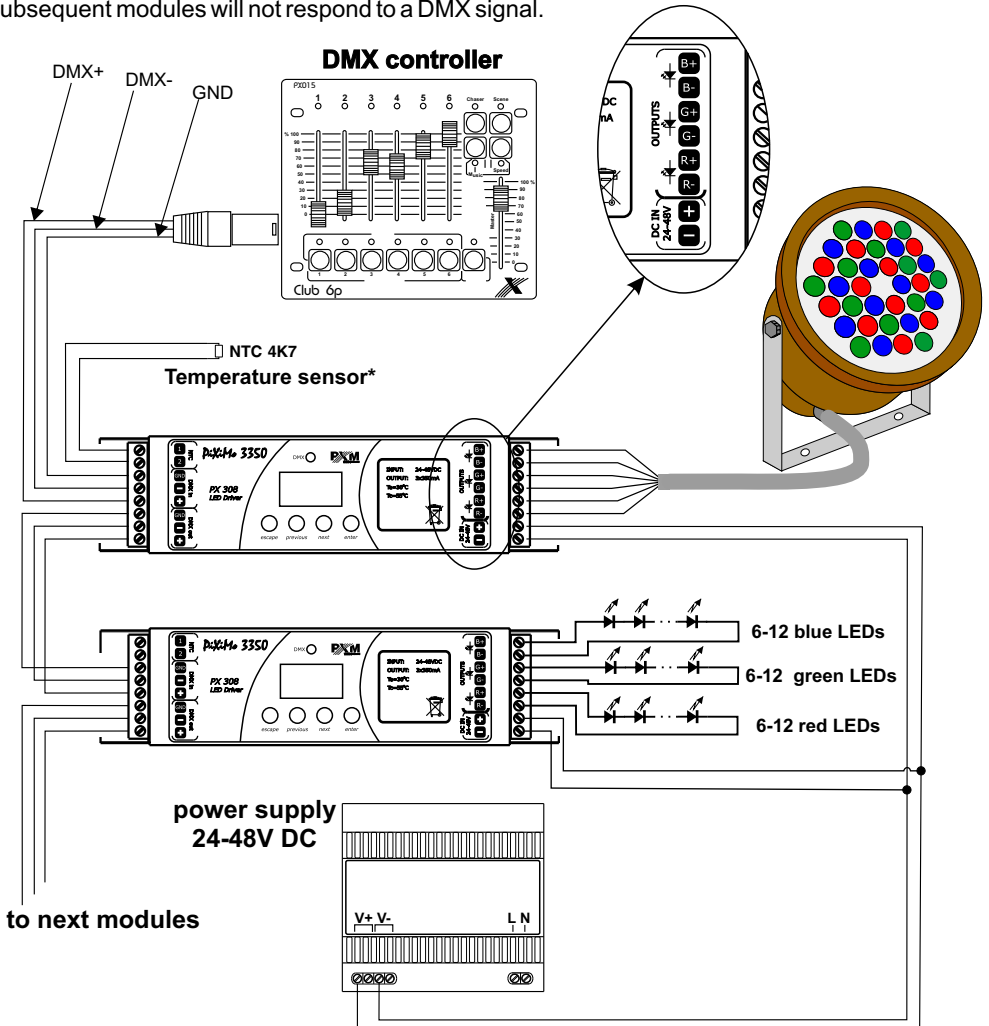

**Caution!!**  
 Temperature measurement will be correct only when applying  
 the NTC 4k7 thermistor installed in the lamp.



## 21. DIMENSIONS

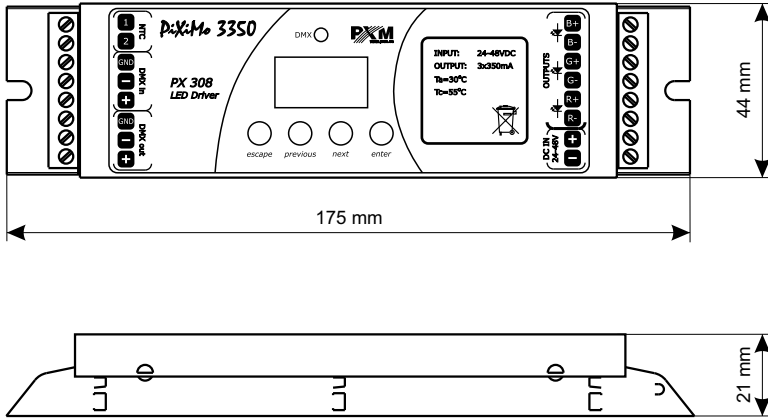

## 22. TECHNICAL SPECIFICATION

- DMX channels	512
- power supply	24 V DC for 6-8 LEDs 48 V DC for 9-12 LEDs
- current consumption	max. 1,1 A
- no-load current consumption	17 mA for 24 V DC 10 mA for 48 V DC
- output channels number	3
- outputs load capacity	350 mA
- control accuracy	16 bit
- programmable scenes	1
- built-in programs	18
- output sockets	terminal block
- MASTER mode	YES
- weight	0,15 kg
- dimensions:	
- width	175 mm
- heigth	44 mm
- depth	21 mm

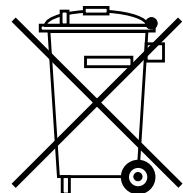



ul. Przemysłowa 12  
30-701 Kraków, Poland

tel: +48 12 626 46 92  
fax: +48 12 626 46 94

e-mail: info@pxm.pl  
http://www.pxm.pl

## DEKLARACJA ZGODNOŚCI z dyrektywą nr 2004/108/WE i 2006/95/WE

Name of producer: PXM Marek Żupnik limited partnership

Address of producer: ul. Przemysłowa 12  
30-701 Kraków, Poland

*declares that the product:*

Name of product: **LED Driver 3 x 350mA / 48V DC**

Type: **PX308**

*answers the following product specifications:*

**LVD: PN-EN 61347-2-13:2008**  
**EMC: PN-EN 61000-6-1:2008**  
**PN-EN 61000-6-3:2008**

*Additional information:*

The DMX-512 connection must be shielded and the shielding must be connected to the ground responding to the DMX connectors.



Marek Żupnik spółka komandytowa  
30-701 Kraków, ul. Przemysłowa 12  
NIP 677-002-54-53

Kraków, 20.02.2014

mgr inż. Marek Żupnik.