

PX241

LED Driver
4 x 350 mA
48 V

MANUAL



CONTENTS

1. General description.....	3
2. Safety conditions.....	3
3. Description of the connectors and control elements.....	4
4. Designation of displayed messages.....	4
5. Device programming.....	7
5.1. Button features.....	7
5.2. DMX addressing: group and individual.....	7
5.3. Colour mode.....	8
5.4. Reaction of the device to DMX signal interruption.....	10
5.5. MASTER/SLAVE function.....	12
5.6. White balance.....	12
5.7. Smooth.....	13
5.8. Light control frequency.....	14
5.9. Screen saving.....	14
5.10. Display function.....	14
5.11. Default settings and memory error.....	15
5.12. Temperature limits and sensor failure.....	16
5.13. RDM description of available parameters.....	18
5.14. Programming scheme.....	22
6. Connection scheme.....	23
7. Dimensions.....	26
8. Technical data.....	26
Declaration of conformity.....	27

Manufacturer reserves the right to make modifications in order to improve device operation.

Rev 1.1

*PXM Marek Żupnik spółka komandytowa
Podłęże 654
32-003 Podłęże*

*tel.: (12) 385 83 06
fax: (12) 626 46 94
E-mail: info@pxm.pl
Internet: www.pxm.pl*

1. GENERAL DESCRIPTION

Driver PX241 is designed to control high power LEDs

Built-in DMX receiver allows to control 4 DMX channels (R, G, B, W) directly with the DMX protocol. Wide range of power supply voltage and high current carrying capacity outputs permit a control of large quantities of LEDs.

PX241 can be either controlled by DMX, and act independently. In this case, the user is able to choose a fully programmable scene and 18 pre-programmed sequences, which can also freely change the playback speed and fluidity changes in steps. By using 16-bit resolution control of each channel is completely smooth.

The driver has a built-in tuning frequency signal system ("flicker free" technology), which makes it particularly useful in applications for the television industry. The RGB LEDs often differ quite substantially in parameters, this can cause problems in obtaining a white color (at full power especially). Therefore PX241 comes with a very useful function called "white balance". Thanks to it you can choose color correction for each set of LEDs controlled by the device to achieve at full power the color white. What's more, this feature also allows you to adjust the color temperature of white color.

2. SAFETY CONDITIONS

PX241 LED Driver is a device powered with safe voltage up to 48 V, however during its installation and use the following rules must be strictly observed:

1. The device may only be connected to 12 - 48 V DC with current-carrying capacity compatible with technical data.
2. All the conductors should be protected against mechanical and thermal damage.
3. In the event of damaging any conductor, it should be replaced with a conductor of the same technical data.
4. Connection of DMX signal can only be made with shielded conductor.
5. All repairs and connections of outputs or DMX signal can only be made with cut off power supply.
6. PX241 should be strictly protected against contact with water and other liquids.
7. All sudden shocks, particularly dropping, should be avoided.
8. The device cannot be turned on in places with humidity exceeding 90%.
9. The device cannot be used in places with temperature lower than 2°C or higher than 40°C.
10. Clean with damp duster only.

3. DESCRIPTION OF THE CONNECTORS AND CONTROL ELEMENTS

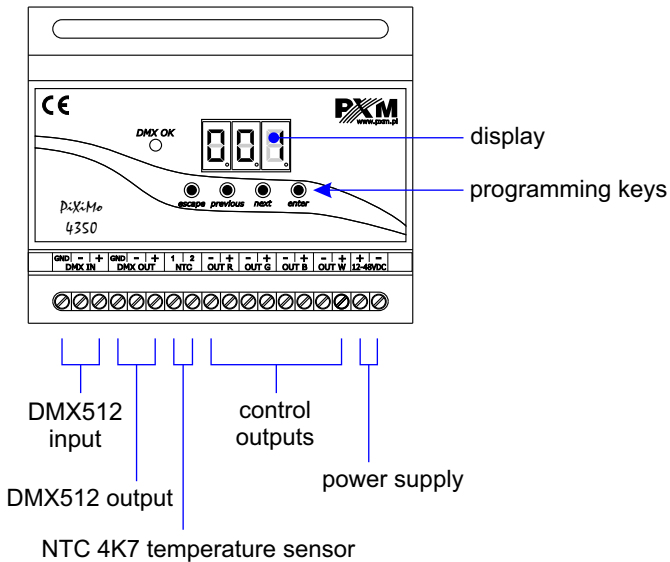

4. DESIGNATION OF DISPLAYED MESSAGES



DMX address of a device - a basic item in the MENU



setting parameters for all channels simultaneously



setting parameters for each channel individually



inverting the meter display 180 degrees



DMX address setting



control method selection (RGB, LIGHTNESS / COLOUR, etc.)



no DMX signal response method selection



MASTER / SLAVE mode settings



LIGHTNESS / COLOUR control mode



RGB control mode



RGBW control mode



RGB Dimmer control mode

468	RGBW Dimmer control mode
H50	HSL control mode - HUE / SATURATION / LIGHTNESS
EFF	effect control mode
800	dynamic white
888	all outputs at 100%
8FF	all outputs off
528	scene
P87	programme no. 17
A81	DMX address settings for first channel
088	MASTER mode on / off
088	number of channels being sent in the MASTER mode
880	white colour balance setting
608	red balance
600	green balance
606	blue balance
608	white colour balance on / off
5P8	program playback speed
F88	level of steps change smoothness in the program
8E8	red during scene programming colour
0P8	green colour during scene programming
600	blue colour during scene programming
888	basic frequency of brightness control
508	screen and DMX signal LED blanking
E88	memory error message

8F0

restore default device settings menu

800

function to limit power

806

value of the limit activation temperature

8H8

value of the maximum limit temperature

800

current temperature

85H

the highest temperature recorded by the sensor

85L

the lowest temperature recorded by the sensor

888

temperature limit is switched off and it is not possible to read the following temperatures: maximum, minimum, and current or when a mode which does not use all channels is set, and unused channels will have the address of the channel

5. DEVICE PROGRAMMING

After you switch on the module, its display shows the program version for a brief moment. To access the main menu, press „enter”, and the display will show **Adr**. Press „previous” or „next” to select the appropriate menu and press „enter” to confirm your selection.

5.1. Button features

- escape** - goes back to the previous MENU level or discards changes made
- previous** - scrolls to the previous feature on the same MENU level or decreases the parameter's value
- next** - scrolls to the next feature on the same MENU level or increases the parameter's value
- enter** - enters the next MENU level and confirms changes made

5.2. DMX addressing: group and individual

The PX241 menu allows the user to set a DMX address in the 1 - 512 range. It is possible to set an address individually **Ind** for each channel or on a group basis “**ALL**” for all the channels simultaneously.

ON A GROUP BASIS

Using the „next” or „previous” keys, set the desired DMX address by selecting values from 1 to 505 - 511 (depending on the control mode selected) and press „enter”. The address thus set will be assigned to the first channel, subsequent DMX addresses will be assigned to subsequent channels.

Once an address is programmed in this manner, the individual settings for each channel are cancelled.

ON AN INDIVIDUAL BASIS

Using this menu you can set a DMX address individually for all the channels (the number of channels depends on the control mode selected).

After you select **Ind** in the main menu, press „enter” to confirm your selection.

Using the „previous” or „next” keys, select the channel you want to set (**Ad1 - Ad8**) and press „enter”.

Using the „previous” or „next” keys, select a value from the range 1 - 512 and press „enter”.

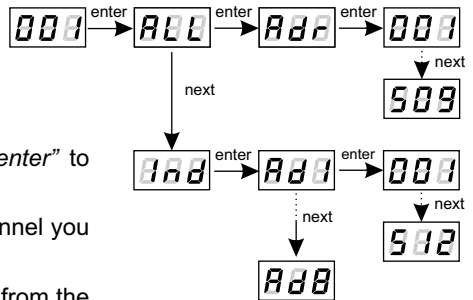

5.3. Colour mode

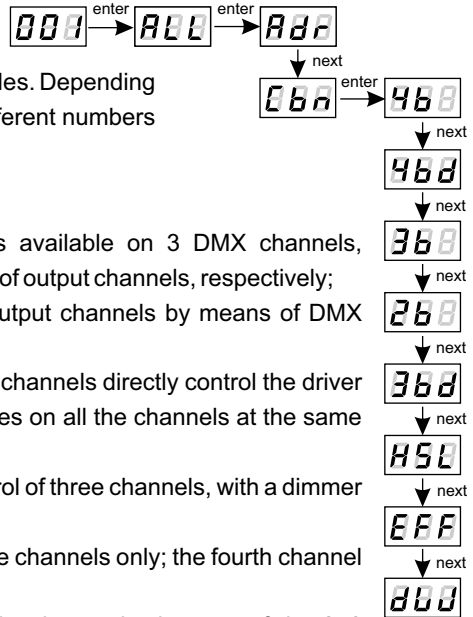

This driver can operate under various control modes. Depending on the mode selected, the device will occupy different numbers of DMX channels.

The following modes are available:

- **HSL** mode (**H**ue, **S**aturation, **L**ightness) is available on 3 DMX channels, responsible for hue, saturation and lightness of output channels, respectively;
- **4b** mode (4-byte) mode - direct control of output channels by means of DMX channels;
- **4bd** mode (4-byte plus a dimmer) - four DMX channels directly control the driver output channels, the fifth channel dims values on all the channels at the same time;
- **3bd** mode (3-byte plus a dimmer) - direct control of three channels, with a dimmer on the fourth channel;
- **3b** mode (3-byte) mode - direct control of three channels only; the fourth channel is inactive;
- **2b** mode (2-byte) - operation in this mode involves selecting one of the 256 colours, defined by the manufacturer, on one DMX channel and lightness on the other DMX channel;
- **dw** mode - dynamic white - control of 2 channel groups: cold white + warm white, by means of four DMX channels. The first DMX channel is responsible for colour temperature of the first group, and the other channel - for lightness of the group. Similarly, the third and the fourth DMX channels control the other group;
- **EFF** mode - an effect control mode. It is available on 8 DMX channels and allows you to select desired effects and their parameters.

Description guide of **EFF** mode settings - (the table on the next page):

- CHANNEL1 - red component
- CHANNEL2 - green component
- CHANNEL3 - blue component
- CHANNEL4 - white component
- CHANNEL5 - operating mode selection
- CHANNEL6 - speed settings (higher value - quicker changes)
- CHANNEL7 - fade settings (higher value - smoother transition)
- CHANNEL8 - lightness settings (higher value - stronger glow)

character ("x")- possibility to control a given parameter of a selected mode

character ("-") - no possibility to control a given parameter of a selected mode

EFF mode (effect) channels description

Channel 1 RED	Channel 2 GREEN	Channel 3 BLUE	Channel 4 WHITE	Channel 5 TRYB	Channel 6 SPEED	Channel 7 FADE	Channel 8 JASNOŚĆ
–	–	–	–	0 ÷ 7 - Program 1	x	x	x
–	–	–	–	8 ÷ 15 - Program 2	x	x	x
–	–	–	–	16 ÷ 23 - Program 3	x	x	x
–	–	–	–	24 ÷ 31 - Program 4	x	x	x
–	–	–	–	32 ÷ 39 - Program 5	x	x	x
–	–	–	–	40 ÷ 47 - Program 6	x	x	x
–	–	–	–	48 ÷ 55 - Program 7	x	x	x
–	–	–	–	56 ÷ 63 - Program 8	x	x	x
–	–	–	–	64 ÷ 71 - Program 9	x	x	x
–	–	–	–	72 ÷ 79 - Program 10	x	x	x
–	–	–	–	80 ÷ 87 - Program 11	x	x	x
–	–	–	–	88 ÷ 95 - Program 12	x	x	x
–	–	–	–	96 ÷ 103 - Program 13	x	x	x
–	–	–	–	104 ÷ 111 - Program 14	x	x	x
–	–	–	–	112 ÷ 119 - Program 15	x	x	x
–	–	–	–	120 ÷ 127 - Program 16	x	x	x
–	–	–	–	128 ÷ 135 - Program 17	x	x	x
–	–	–	–	136 ÷ 143 - Program 18	x	x	x
–	–	–	–	144 ÷ 151 - OFF	–	–	–
x	x	x	x	152 ÷ 169 - Strobo 10%	x	x	x
x	x	x	x	170 ÷ 199 - Strobo 20%	x	x	x
x	x	x	x	200 ÷ 229 - Strobo 50%	x	x	x
x	x	x	x	230 ÷ 255 - RGBD	–	–	x

5.4. Reaction of the device to DMX signal interruption

This function is used both to protect the system against disappearance of DMX signal and to gain control of LEDs without connecting an external driver. After it has been activated, in case of the lack of DMX signal, the module will perform the selected function by itself. Reconnection of DMX signal will automatically break the performed function, and the module will again send the command with DMX line.

- P01 - P18** - 18 ready programs are available. For each of them, the user can set the playback speed **Spd** (value from 0.1 to 99.9 seconds) and the step change frequency in **FAd** (value from 0, i.e. abrupt transition, to 100, i.e. totally smooth transition)
- Sc** - programming the scene value for red (**rEd**) channel, for green (**Grn**) channel, for blue (**bLu**) channel, for white (**HtE**) channel, as well as the scene entrance time (**SPd**) (value from 0.1 to 99.9 seconds)
- on** - switching on of all outputs at 100% for which **Spd** is defined – switching time at 100% (0.1+99.9 s)
- oFF** - complete switch-off of outputs

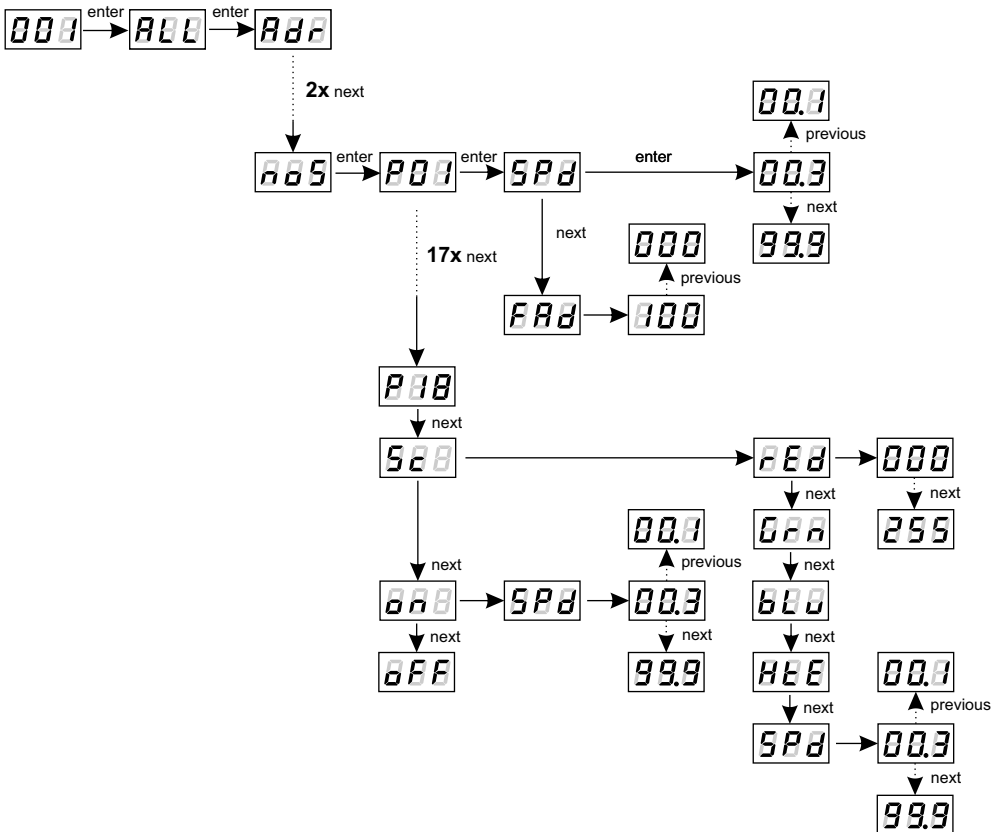

DESCRIPTION OF PROGRAMS

The following tables show the values for each output channel - R, G, B and W in programs from 1 up to 18 (**P01 - P18**). The value of 255 corresponds to the maximum lightness level on a given channel, 127 - 50% of power level, 0 - full channel blanking.

		P01	P02	P03	P04	P05	P06	P07	P08	P09	P10
step 1	R	255	0	0	0	255	255	0	255	0	255
	G	0	0	0	0	0	0	255	0	255	0
	B	0	255	0	0	0	0	255	0	0	0
	W	0	0	255	0	255	0	0	0	255	0
step 2	R	0	0	255	0	255	255	0	0	0	0
	G	255	255	0	0	255	0	255	255	0	0
	B	0	0	0	255	0	255	0	0	255	255
	W	0	0	0	0	0	0	255	0	0	0
step 3	R	0	255	0	0	0	0	255			
	G	0	0	0	0	255	0	255			
	B	255	0	0	0	0	255	0			
	W	0	0	255	0	255	0	0			
step 4	R			0	0	0	0				
	G			255	255	255	255				
	B			0	0	255	255				
	W			0	0	0	0				
step 5	R			0	0	0	0				
	G			0	0	0	255				
	B			0	0	255	0				
	W			255	0	255	0				
step 6	R			0	255	255	255				
	G			0	0	0	255				
	B			255	0	255	0				
	W			0	0	0	0				

		P11	P12	P13	P14	P15	P16	P17	P18
step 1	R	0	0	0	255	0	0	0	0
	G	0	0	0	0	255	0	127	0
	B	0	0	0	0	0	255	255	0
	W	0	0	0	127	127	127	0	0
step 2	R	255	0	0	255	127	127	127	255
	G	0	255	0	127	255	0	255	255
	B	0	0	255	0	0	255	127	255
	W	0	0	0	0	0	0	0	255
step 3	R				255	0	0	255	
	G				0	255	0	127	
	B				0	0	255	0	
	W				127	127	127	0	
step 4	R				255	0	0	127	
	G				0	255	127	0	
	B				127	127	255	127	
	W				0	0	0	0	

5.5. MASTER / SLAVE function

The PX241 module has a built-in DMX512 receiver and can be controlled from any desktop or controller running in this standard. Moreover, it is equipped with a programmable function of response to no DMX signal (**noS**). With 18 built-in default programs, it is possible to obtain interesting effects without an external controller. However, in larger installations, several PX241 drivers implementing the same program cannot provide a full reproduction synchronisation. Therefore, PX241 has a MASTER feature. When it is activated, the module changes from a DMX receiver into a transmitter of this signal and sends self-realized programs to the other modules. The first driver on the DMX line should be assigned MASTER status. The other drivers should operate in SLAVE mode.

With this solution, it is possible to make a precise synchronization even in very large installations.

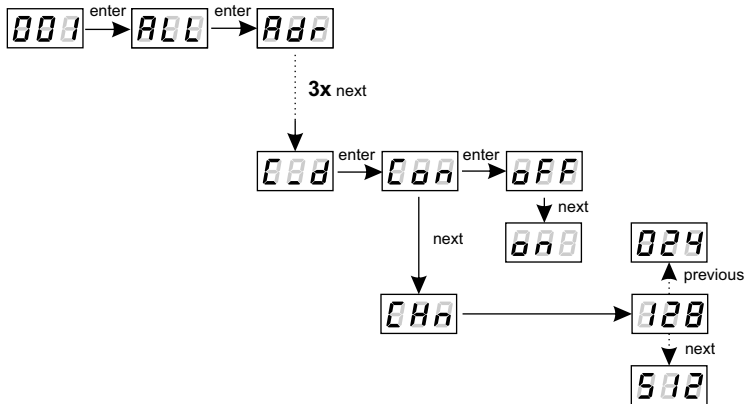

Con - turning on or off the MASTER function

CHn - select the amount of DMX channels sent

NOTE:

PX241 sends 4 channels which are duplicated at the output to the desired quantity (24-512).

5.6. White balance

Sometimes, there may be problems achieving white colour on the LEDs of RGB series. This may be due to the use of diodes with different technical parameters. For this reason, the PX241 module is equipped with a white balance function (**bAL**). This option allows you to select the proper colour temperature for the full control of all four outputs (white colour) in the range of 0- 100%.

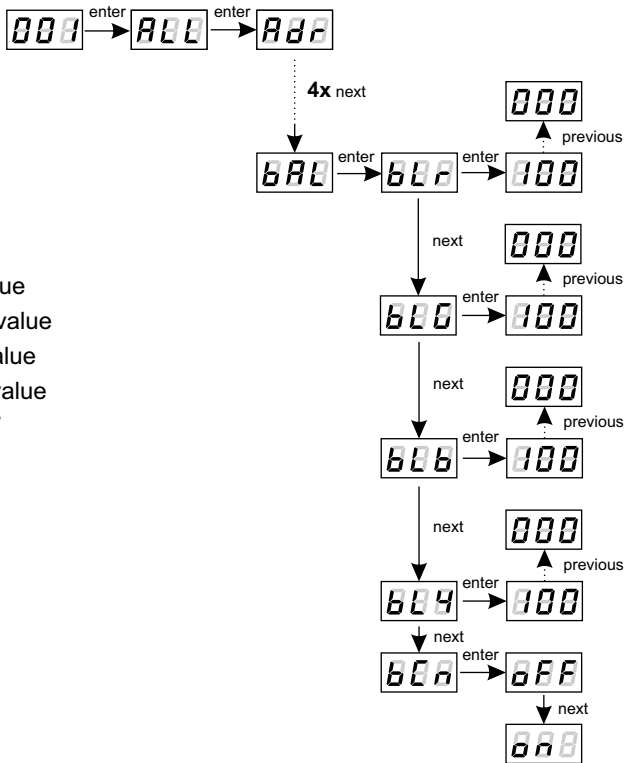

- bLr** - setting the red colour value
- bLG** - setting the green colour value
- bLb** - setting the blue colour value
- bLY** - setting the white colour value
- bCn** - white balance *on* or *off*

5.7. Smooth

The driver has an option of smoothing the output signal. Smooth feature allows for smooth changes in lightness and colour. When the transition between successive DMX values sent to the lamp is turned on (e.g. corresponding to changes in lightness) the changes are smooth with no visible twitches, which prevents the common light "vibrations" effect. Two consecutive DMX values sent to the lamp are smoothed linearly between the DMX signal packets for the selected **P2P** option or the time interval set in the menu.

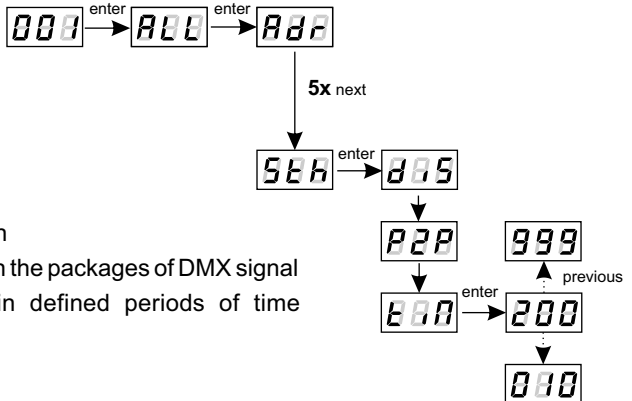

- diS** - the smoothing option is on
- P2P** - linear smoothing between the packages of DMX signal
- tim** - setting of smoothing in defined periods of time (10 ms - 999 ms)

5.8. Light control frequency

The **Frq** function allows for setting the basic control frequency. This feature is extremely useful for controlling lamps for the television industry. By applying the "flicker free" technology, it is possible to avoid the unpleasant flickering effect which is caused by improper signal synchronization that controls the LEDs.

The user can choose from the available frequency range from 366 Hz up to 25 kHz which can be smoothly changed using the „previous" or „next" buttons and selecting a different value.

Frequency values above 1.51 kHz can avoid flickering in the camera.

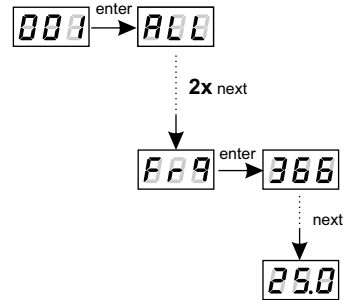

5.9. Screen saving

The device is equipped with a feature that allows for turning off the backlight. The **SCr** option activated turns off the display after a minute of inactivity (do not use the keys). The device continues its operation without interfering with other parameters. Press any key to restore the backlight.

- on** - screen saver activation
- oFF** - screen saver deactivation

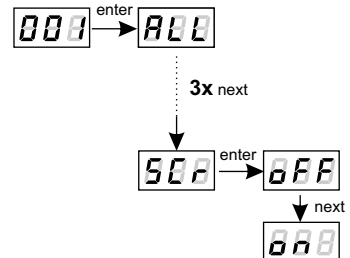

5.10. Display function

As the driver should be installed (as far as possible) in a small distance from the controlled LEDs, the lack of space may force the necessity of mounting the device upside-down. In such case the displayed messages become illegible, that does not have the influence on device operation, but makes the programming much more difficult.

That is why the PX241 driver has a display flip feature available. It turns the screen 180°. The keys order is reversed as well.

To activate this both middle buttons ("previous" and „next") of the driver have to be pressed in the same time for about 3s. To deactivate function the procedure is the same.

The figure on the next page shows how flip function works.

standard position

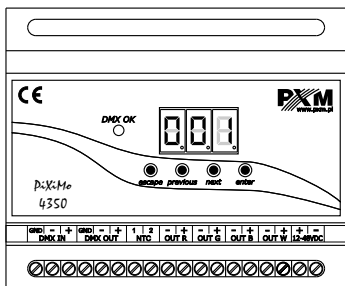

upside-down position

buttons are placed in the same way as in normal position; display is flipped

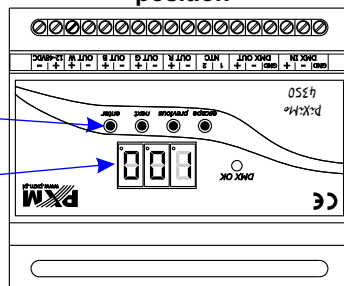

5.11. Default settings and memory error

If you have any difficulty accessing the device menu, e.g. it is not possible to enter a particular menu level or it is necessary to restore the device to its default settings, follow the instructions below.

In the first case, if there is no access to the menu level or it is incorrectly displayed, this may indicate an error of saving to the device memory.

If the procedure has been performed and the device still does not operate properly, it must be sent to the manufacturer.

To restore the device to its default settings, press and hold the previous key while switching on the device. One of the messages that will be displayed will say **dFI**, which means successful restoring to default settings (the previous key has to be held down while powering on the device, until the **dFI** message is displayed).

If this message is accepted by pressing „enter”, the default settings will be restored. The user can also exit this menu level without restoring the default settings. In order to do this, press the „esc” key.

Please note that all set parameters of the PX241 device after restoring the default settings will be changed to those shown below:

- DMX address - 1,
- driver operating mode - RGBW (4b - 4-byte),
- master mode - off,
- number of sent DMX channels - 128,
- white balance - off
- no signal operating mode - Program 1
- smoothing function (smooth) - off

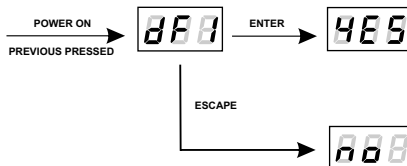

Err message - memory error

The device is equipped with a built-in memory work control function.

If there are problems with the memory operation on the PX241 display, the **Err** message appears - memory error.

The course of the power limitation between **Lo** and **Hi** values is linear as shown in the graph below:

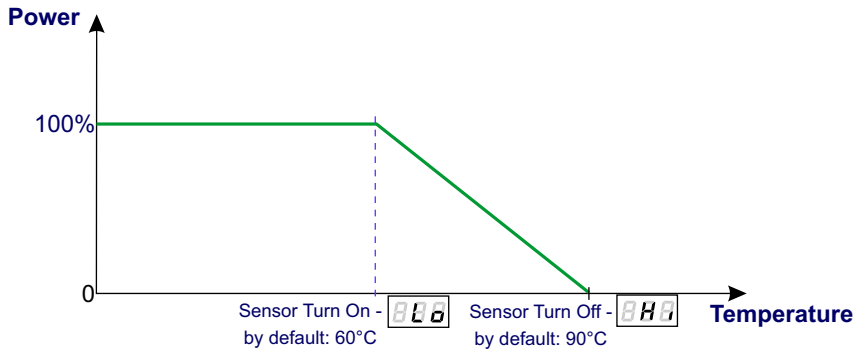

If this function is activated and the temperature sensor is incorrectly connected or there is no sensor, the driver displays a relevant message – **Er0** at the current temperature location, and instead of the first DMX address, i.e. at the very beginning of the menu. To disable the message, connect an appropriate sensor or disable the temperature limit.

5.13. RDM description of available parameters

The PX241 supports the DMX-RDM protocol. DMX protocol allows only of a one-way data transmission, while its extension the RDM protocol can transmit information in two directions. This makes possible to simultaneously send and receive information, and hence the possibility of monitoring activities of the compatible devices. Thanks to RDM some available settings of compatible devices may be programmed using this protocol.

Below is a list of RDM parameters supported by the PX241:

Parameter name	PiD	Description
SUPPORTED_PARAMETERS	0x0050	all supported parameters
PARAMETER_DESCRIPTION	0x0051	description of additional parameters
DEVICE_INFO	0x0060	information concerning the device
SOFTWARE_VERSION_LABEL	0x00C0	firmware version of the device
DMX_START_ADDRESS *	0x00F0	DMX starting address of the device; minimum value: 1, maximum value: 512. According to the RDM standard, for device whose footprint is 0, the value of this parameter may be 65535 and then it is not possible to change the initial address settings for the entire device, but only for sub-devices.
IDENTIFY_DEVICE *	0x1000	device identification; Two states are possible: identification is off (0x00 value) and identification is on (0x01 value).
STATUS_MESSAGES	0x0030	information about device status
DEVICE_MODEL_DESCRIPTION	0x0080	device description, e.g. name
MANUFACTURER_LABEL	0x0081	manufacturer description, e.g. name
DEVICE_LABEL *	0x0082	additional device description; It is possible to enter an additional device description using up to 32 ASCII characters.
FACTORY_DEFAULTS	0x0090	device default settings
DMX_PERSONALITY	0x00E0	DMX operational mode
DMX_PERSONALITY_DESCRIPTION	0x00E1	description of individual operational modes
DEVICE_HOURS	0x0400	operating time counted in hours
TEMPERATURE_LIMIT_ON/OFF	0x800E	temperature limitation activation for the temperature sensor connected to the driver; For 0 value, the function is not active; for 1 value, the function is active. Default value is 1.

Parametr name	PiD	Description
TEMPERATURE_THRESHOLD_LOW *	0x800F	lower temperature value for which the temperature limitation is being activated
TEMPERATURE_THRESHOLD_HIGH *	0x8010	upper temperature value for which the temperature limitation is active, i.e. the cut-off temperature for exits from the driver
BALANCE_RED *	0x8011	value of control level of red channel balance; Minimum value is 0 and maximum is 100 (the value equals to percentage of control level). For the maximum value (100) the LEDs work with maximum brightness. Default value is 100.
BALANCE_GREEN *	0x8012	value of control level of green channel balance; Minimum value is 0 and maximum is 100 (the value equals to percentage of control level). For the maximum value (100) the LEDs work with maximum brightness. Default value is 100.
BALANCE_BLUE *	0x8013	value of control level of blue channel balance; Minimum value is 0 and maximum is 100 (the value equals to percentage of control level). For the maximum value (100) the LEDs work with maximum brightness. Default value is 100.
BALANCE_WHITE *	0x8014	value of control level of white channel balance; Minimum value is 0 and maximum is 100 (the value equals to percentage of control level). For the maximum value (100) the LEDs work with maximum brightness. Default value is 100.
SMOOTH_DIS_0/P2P_1/TIM_2 *	0x801A	the choice of options relating to the Smooth function; At 0 value Smooth is turned off, for a value of 1 Smooth mode is set to a Packet to Packet (P2P) and for the value of 2 Smooth is in time mode (tim). The default value is 0 - Smooth off.
SMOOTH_TIME *	0x801B	smooth time for tim function chosen in subsection above; Unit in [ms]. Minimal value of this parameter is 10 and maximal 999 [ms]. Default value is 200.

Parametr name	PiD	Description
NO_SIG_P1-18 SC_19 ON_20 OFF_21	0x801C	choice of work mode for No DMX signal; Minimal Value is 1, maximal 21. For values 1-18 menu allows to chose program from 1 to 18 which is played during no DMX signal detection. For the 19 value a scene saved in memory is set and for the 20 value all outputs are set to ON with maximum value. The value 21 sets to OFF all outputs during time with no DMX signal received. Default value is 21.
SCENE_RED *	0x801D	settings of red channel value for scene saved; Minimal value is 0, maximal 255 (maximal brightness). By default value set to 255.
SCENE_GREEN *	0x801E	settings of green channel value for scene saved; Minimal value is 0, maximal 255 (maximal brightness). By default value set to 255.
SCENE_BLUE *	0x801F	settings of blue channel value for scene saved; Minimal value is 0, maximal 255 (maximal brightness). By default value set to 255.
SCENE_WHITE *	0x8020	settings of white channel value for scene saved; Minimal value is 0, maximal 255 (maximal brightness). By default value set to 255.
SCREENSAVER_ON/OFF *	0x8024	settings of screensaver; With the 0 value display blanking is not active, the 1 value means screensaver active. Default value is 0.
PROGRAM_SPEED *	0x8025	programs playback speed settings (playing next steps of program); Minimum value is 1 and maximal 999 (maximum speed). By default it is set to 10. Value 1 represents 0,1s, and 999 - 99,9s.
PROGRAM_FADE *	0x8026	settings of smooth transition between following steps of a program; The minimum value is 0 (step transition) a maximum of 100 (transition completely smooth). The default value is 100.

Parametr name	PiD	Description
BALANCE ON/OFF *	0x8027	to activate or deactivate the balance of output channels; A value of 0 is a balance off, a value of 1 active balance. The default value is set to 0.
PWM_FREQUENCY *	0x8028	LEDs refresh frequency; The minimum value is 366 and the maximum is 25000. The unit is [Hz] and the default value is 366.
SERIAL_NUMBER	0x8030	device serial number
DISPLAY_FLIP *	0x8031	inverting the meter display 180 degrees; The minimum value is 0, and the maximum is 1. The default value is 0.

* - parameter editable

6. CONNECTION SCHEME

a) version with temperature sensor connection

Controlled LEDs should only be connected using 8 strand wires (for 4 channels connection) or 10 for PX241 version with temperature sensor

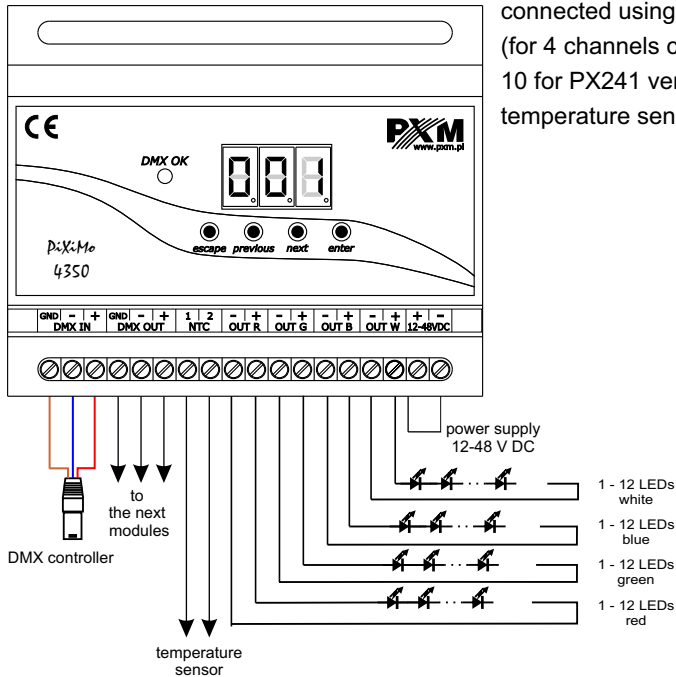

b) connection of 2 PX225 RGBW lamps to the PX241 LED driver.

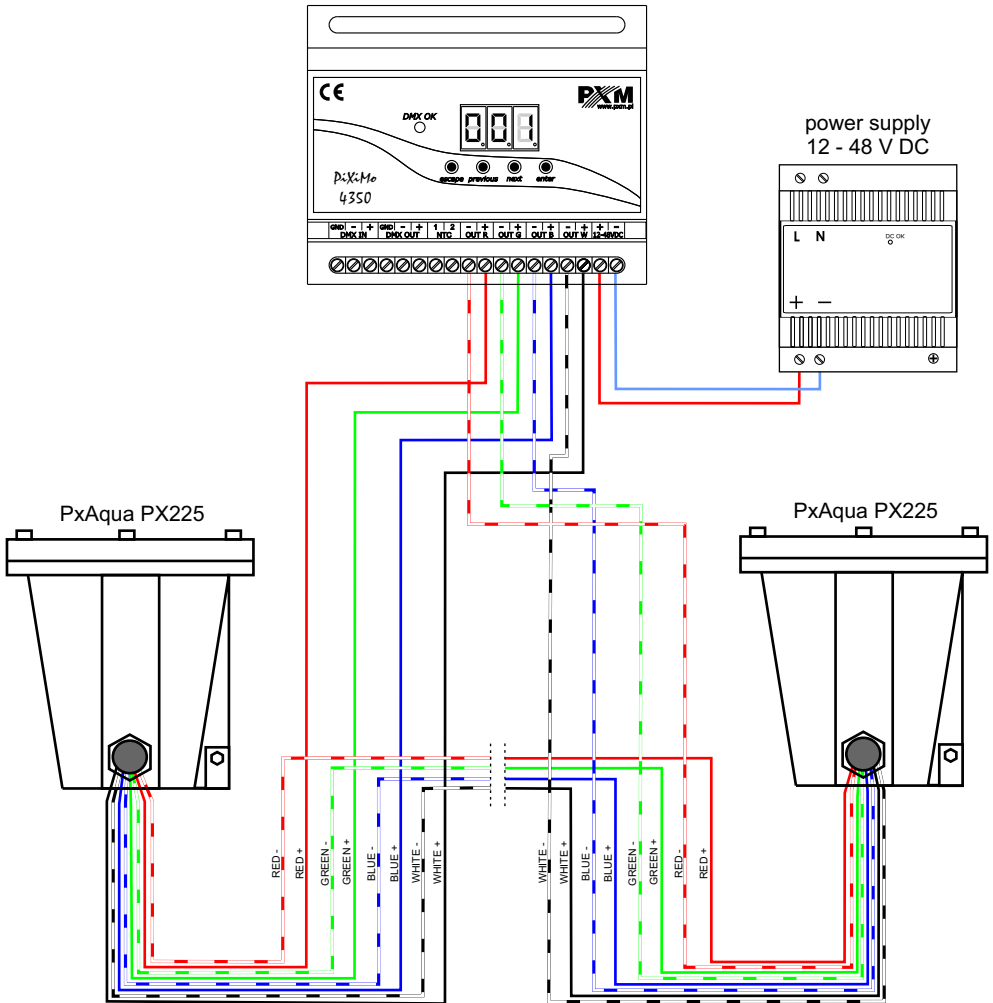

c) monochrome lamp in DW mode connection diagram

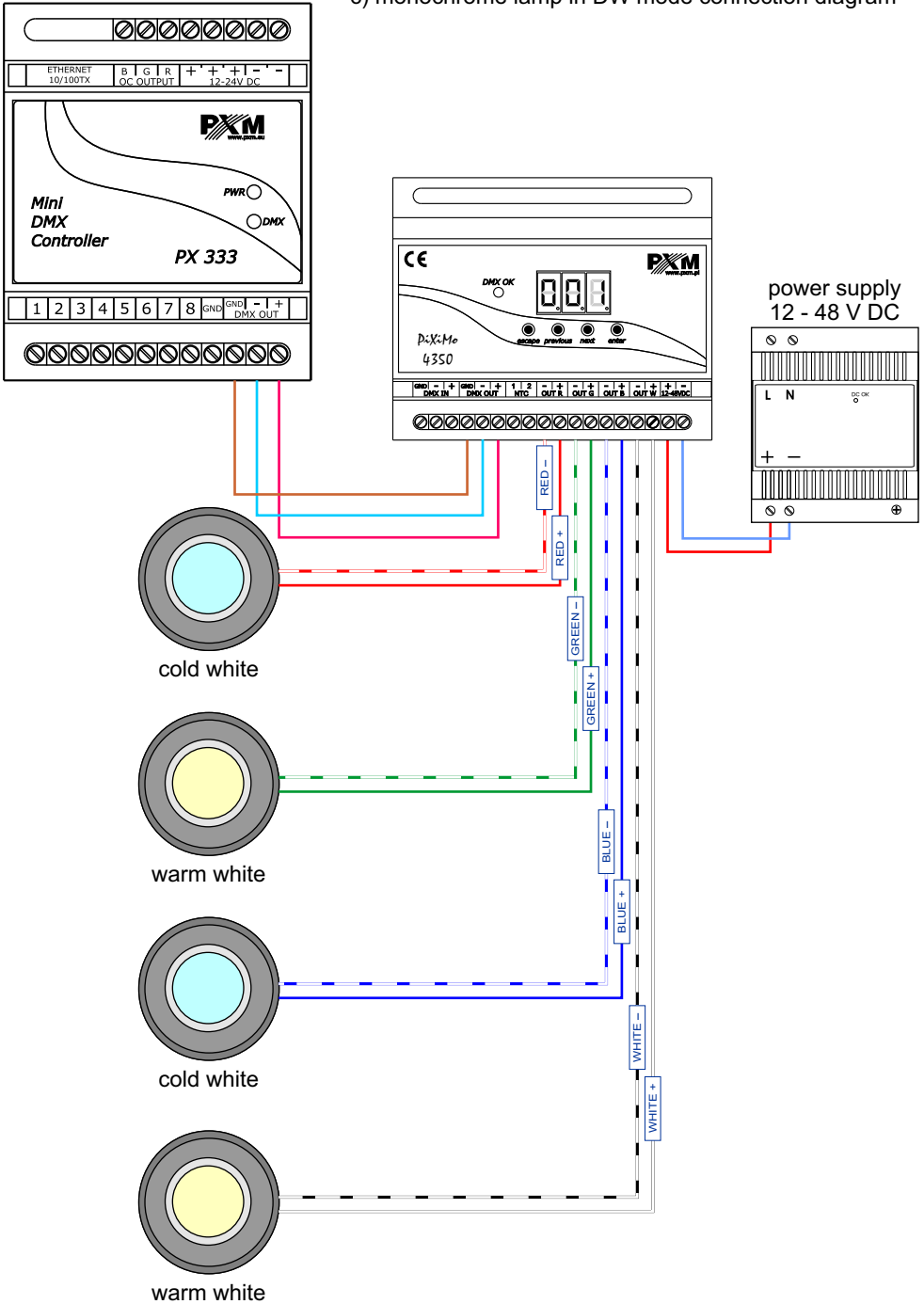

7. DIMENSIONS

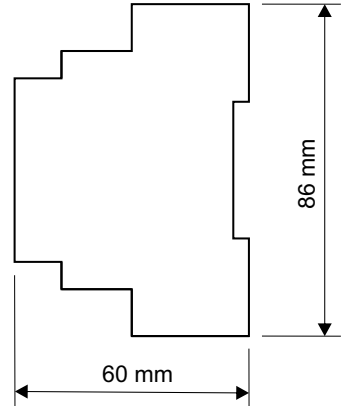
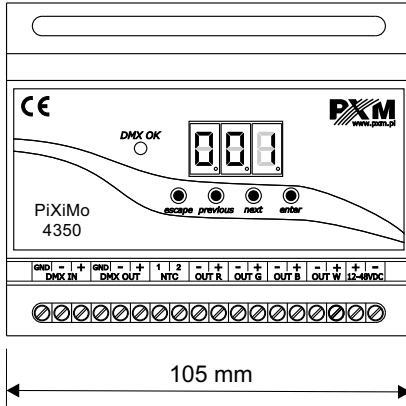

8. TECHNICAL DATA

- DMX channels	512
- power supply	12 V DC for 1, 2 or 3 LED for channel 24 V DC for 4, 5 or 6 LED for channel 48 V DC for 7, 8, 9, 10, 11 or 12 LED for channel
- maximum current consumption	1,4 A
- current consumption without load	1 W for 12 V DC; 1,2 W for 24 V DC; 1,5 W for 48 V DC
- output channels	4
- accuracy of control	16 bit
- programmable scenes	1
- built-in programs	18
- outputs load capacity	350 mA / channel
- output terminals	terminal block
- MASTER mode	yes
- dimensions:	
- length	105 mm (6 separate rail modules)
- width	86 mm
- height	60 mm





Podłężę 654
32-003 Podłężę

tel: 012 385 83 06
fax: 012 626 46 94

e-mail: info@pxm.pl
http://www.pxm.pl

DECLARATION OF CONFORMITY

PXM Marek Żupnik spółka komandytowa
Podłężę 654, 32-003 Podłężę

we declare that our product:

Product name: **PiXiMo 4350**

Product code: **PX241**

smeets the requirements of the following standards as well as harmonised standards:

PN-EN 50581:2013,	EN 50581:2012
PN-EN 61000-4-2:2011,	EN 61000-4-2:2009
PN-EN 61000-6-1:2008,	EN 61000-6-1:2007
PN-EN 61000-6-3:2008,	EN 61000-6-3:2007

and meets the essential requirements of the following directives:

2011/65/UE DIRECTIVE OF THE EUROPEAN PARLIAMENT AND OF THE COUNCIL of 8 June 2011 on the restriction on the use of certain hazardous substances in electrical and electronic equipment.

2014/30/UE DIRECTIVE OF THE EUROPEAN PARLIAMENT AND OF THE COUNCIL of 26 February 2014 on the harmonisation of the laws of the Member States relating to electromagnetic compatibility and repealing Directive 2004/108/EC.



Marek Żupnik spółka komandytowa
32-003 Podłężę, Podłężę 654
NIP 677-002-54-53

Podłężę, 26.09.2017

mgr inż. Marek Żupnik.