

PX232

DMX/Relay  
Interface 1ch

User manual



# Table of Contents

1 Description.....	3
2 Safety conditions.....	4
3 Connectors and control elements.....	5
4 DMX address settings.....	6
5 DMX signal connecting.....	7
6 Connection scheme.....	8
7 Dimensions.....	9
8 Technical data.....	9

*Manufacturer reserves the right to make modifications in order to improve device operation.*

PXM Marek Żupnik sp.k.  
Podłęże 654  
32-003 Podłęże  
BDO register number 000005972

tel. +48 12 385 83 06  
mail: [info@pxm.pl](mailto:info@pxm.pl)  
[www.pxm.pl](http://www.pxm.pl)

Rev.1-3  
04.07.2019

# 1 Description

---

DMX/Relay Interface 1ch is a relay controlled by a DMX-512 protocol.

PX232 is a device designated for switching on and off effects on stage and architectural illumination via DMX-512.

The module contains a transmitter that controls the on / off output. It has a built-in hysteresis, which eliminates phenomenon vibration of relays' contacts. The module output turn on beyond the DMX value of 191. Relay turns off below the value of 64. Method of operation is shown on the diagram below:

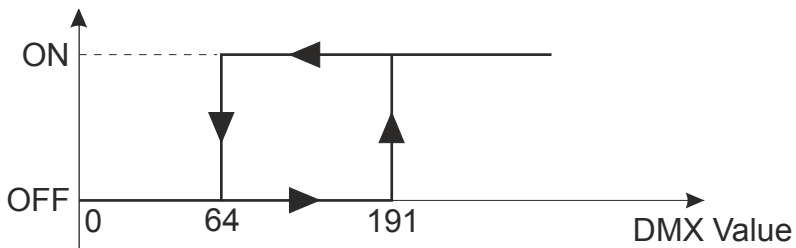

The device is equipped with input and output DMX signal. Housing is adapted for mounting on DIN rail (35mm) and is also 35mm wide (the size of 2 modules).

## 2 Safety conditions

---

The PX232 is a device powered directly from power grid 230V AC, what may result in electric shock in case of not following safety rules. During its installation and use the following rules must be strictly observed:

1. Installation of the device should be carried out by a person with appropriate qualifications in accordance with this document.
2. The electrical outlet to which the switch is connected have to be linked to a working protective installation (3-wire installation).
3. Protect the power cord from mechanical and thermal damage.
4. In case of damage the power cord, cable, replace it with the same technical data and certificates.
5. For connecting devices to the DMX/Relay Interface 1ch use only 3-wire cables with cross-section of not less than 1,5mm<sup>2</sup>.
6. All repairs and connections of outputs or DMX signal can only be made with cut off power supply.
7. PX232 should be strictly protected against contact with water and other liquids.
8. All sudden shocks, particularly dropping, should be avoided.
9. Do not connect the device with a damaged (broken) housing to the power supply.
10. The device cannot be turned on in places with temperature lower than +2°C or higher than +40°C.
11. The device cannot be used in places with humidity exceeding 80%.
12. Clean it with damp duster only.

### 3 Connectors and control elements

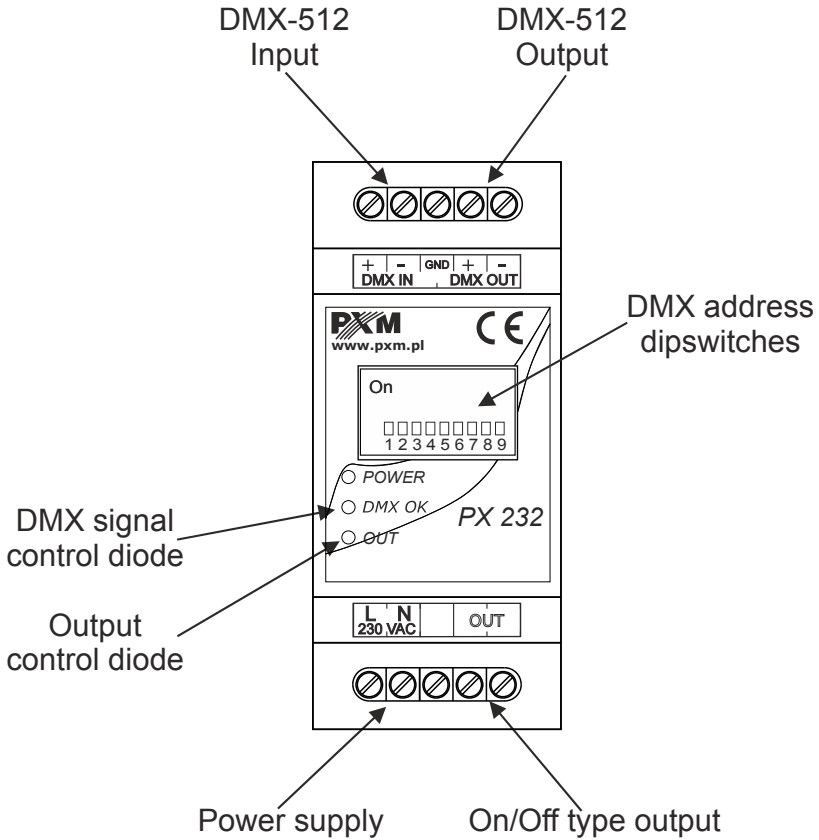

# 4 DMX address settings

The PX232 allows to set an address on a single DMX channel. The start address is set in binary code using a switch-type “DIP switch”. Here are some sample settings for the start address.

1		11		100	
2		12		101	
3		13		102	
4		14		103	
5		:	:	104	
6		70		105	
7		71		:	:
8		72		249	
9		73		250	
10		74		251	

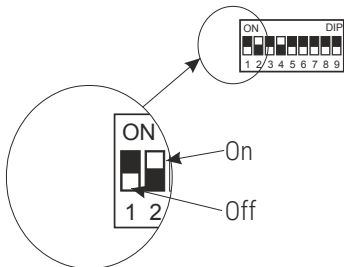

White color shows position of the switch. In upper position DIP switch is ON and in lower position it is OFF.

# 5 DMX signal connecting

PX232 have to be connected to DMX line in serial mode, with no branches on DMX control cable. That means that DMX line, from the signal source, must be connected to **DMX IN** pins of PX232 and later, directly from **DMX OUT** pins to the next device in DMX chain.

If the PX232 is the last DMX chain receiver there should be terminator (resistor 120 Ohm) mounted between **DMX+** and **DMX-** pins of **DMX OUT** section.

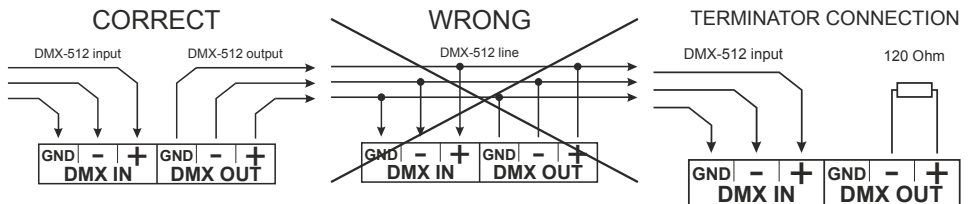

# 6 Connection scheme

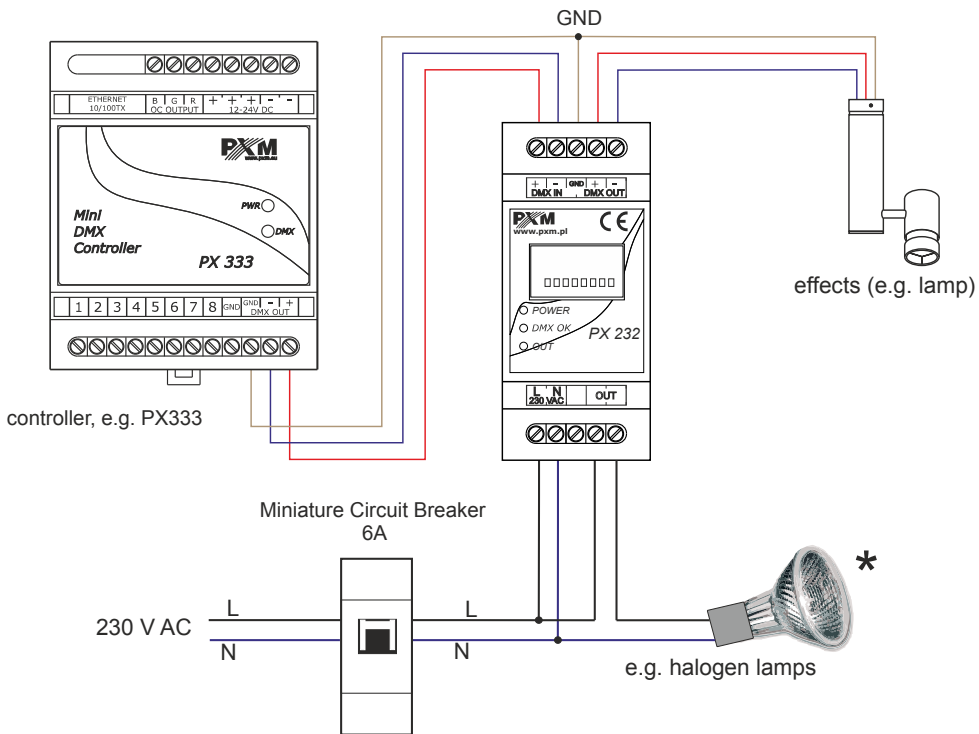

\* - in the case of inductive load, additional power contactors should be used



## 7 Dimensions

---

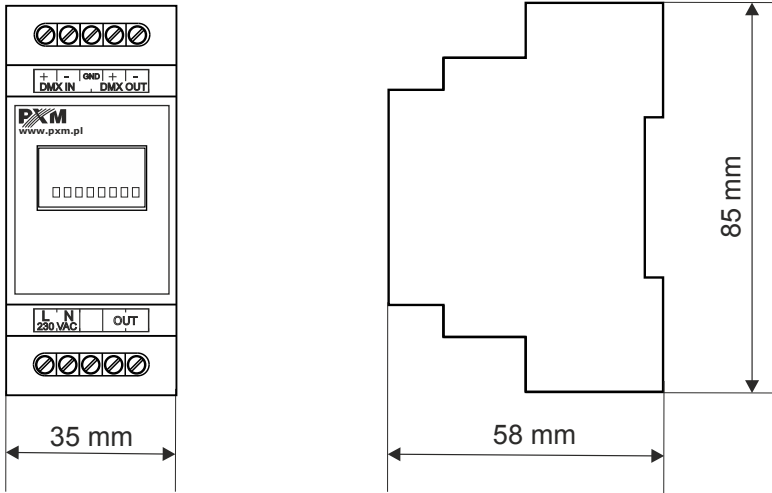

## 8 Technical data

---

type	PX232
power supply	230V AC
DMX channels	511
number of output channels	1
output load	resistive: max. 6A, 250V AC inductive: max 3A, 250V AC
current consumption	max. 16mA
output connections	terminal blocks
weight	0.2kg
dimensions	width: 35mm height: 85mm depth: 58mm

## DECLARATION OF CONFORMITY

PXM Marek Żupnik spółka komandytowa  
Podłęże 654, 32-003 Podłęże

we declare that our product:

*Product name:* DMX/Relay Interface 1ch

*Product code:* PX232

meets the requirements of the following standards, as well as harmonised standards:

PN-EN IEC 63000:2019-01

EN IEC 63000:2018

PN-EN 61000-4-2:2011

EN 61000-4-2:2009

PN-EN IEC 61000-6-1:2019-03

EN IEC 61000-6-1:2019

PN-EN 61000-6-3:2008

EN 61000-6-3:2007

and meets the essential requirements of the following directives:

2011/65/UE **DIRECTIVE OF THE EUROPEAN PARLIAMENT AND OF THE COUNCIL** of 8 June 2011 on the restriction of the use of certain hazardous substances in electrical and electronic equipment  
Text with EEA relevance.

2014/30/UE **DIRECTIVE OF THE EUROPEAN PARLIAMENT AND OF THE COUNCIL** of 26 February 2014 on the harmonisation of the laws of the Member States relating to electromagnetic compatibility (recast)  
Text with EEA relevance.

  
**Marek Żupnik spółka komandytowa**  
32-003 Podłęże, Podłęże 654  
NIP 677-002-54-53



mgr inż. Marek Żupnik.