

PX227

DMX/0-10V

Interface 8ch

User manual



# Table of Contents

1 Description.....	3
2 Safety conditions.....	4
3 Connectors and control elements.....	5
4 Programming.....	6
4.1 Programming of group parameters.....	6
4.1.1 Setting of DMX address.....	7
4.1.2 Feature of output channels.....	7
4.1.3 Programming of individual parameters.....	8
4.2 Response to the loss of DMX signal.....	9
4.3 Smoothing function.....	11
4.4 Screen blanking.....	12
4.5 Default settings and device errors.....	13
4.5.1 Restore default settings.....	13
4.5.2 Error message.....	14
5 Mounting.....	15
6 Menu scheme.....	16
7 RDM – available parameters.....	17
8 DMX signal connecting.....	19
9 Connection scheme.....	20
10 Dimensions.....	21
11 Technical data.....	21

Manufacturer reserves the right to make modifications in order to improve device operation.

PXM Marek Żupnik sp.k.  
Podłęże 654  
32-003 Podłęże  
BDO register number 000005972

tel. +48 12 385 83 06  
mail: info@pxm.pl  
www.pxm.pl

Rev.2-0  
18.08.2021

# 1 Description

---

Demultiplexer DMX-512 signal on 0 – 10V.

The PX227 is designed to process the DMX512 signal to control the eight analog 0 – 10V outputs with accuracy  $\pm 3\%$ .

In addition to simple decoding DMX signal the PX227 allows to select the characteristics of control and program unit reacts to loss of DMX signal. Individually programmable parameters allow to define independent for each channel DMX address from range 1 – 512. What is more it is possible to arbitrarily assign multiple channels to a single address.

DMX / 0-10V Interface 8ch has been placed in a housing adapted for mounting on a 35mm DIN rail and is powered by a safe voltage of 12 – 24V DC.

From software version 2.06, support for the RDM protocol has been implemented.

**NOTE!** The following user manual applies to devices from serial number 21290007.

## 2 Safety conditions

---

PX227 is a device powered by low voltage equal to 12 – 24V DC; however, please observe the following safety rules during its installation and use:

1. The device may be connected to 12 – 24V DC with current-carrying capacity compatible with technical data.
2. All the conductors should be protected against mechanical and thermal damage.
3. In the event of damaging any conductor, it should be replaced with a conductor of the same technical data.
4. Only use a shielded cable for connecting the DMX signal.
5. All repairs and connection of outputs or DMX signal can only be made with cut off power supply.
6. PX227 should be strictly protected against contact with water and other liquids.
7. All sudden shocks, particularly dropping, should be avoided.
8. The device cannot be turned on in places with humidity exceeding 90%.
9. The device cannot be used in places with temperature lower than +2°C or higher than +40°C.
10. Clean with damp cloth only – when the power is off.

# 3 Connectors and control elements

Pin no.	Connection
13	GND (-)
14	GND (-)
23	GND (-)
24	GND (-)
15	OUT 1 (+)
16	OUT 2 (+)
17	OUT 3 (+)
18	OUT 4 (+)
19	OUT 5 (+)
20	OUT 6 (+)
21	OUT 7 (+)
22	OUT 8 (+)
4	DC + power type
5	DC + power type
6	DC + power type
1	DC - power type
2	DC - power type
3	DC - power type
10	DMX IN +
11	DMX IN -
12	DMX IN GND
7	DMX OUT +
8	DMX OUT -
9	DMX OUT GND

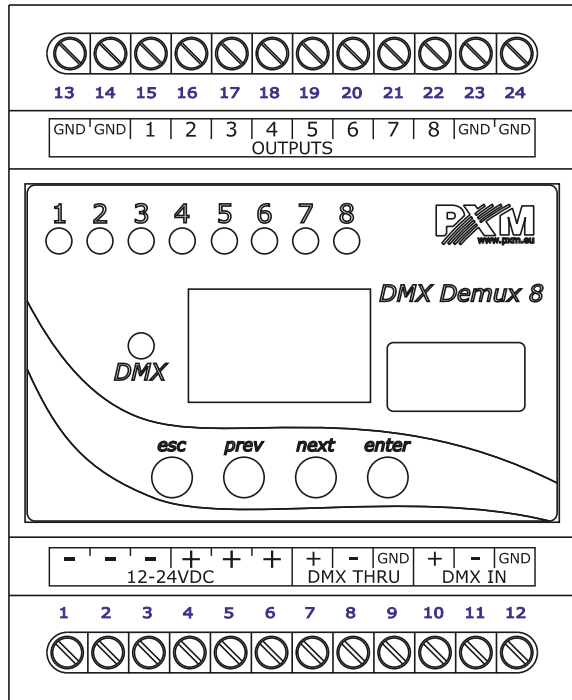

# 4 Programming

---

After switching on, the display shows the version of the program. During the normal operation of demultiplexer, the display shows DMX address. Press *enter* to go the main menu, the display shows **ALL**. Press *prev* or *next* to select the programming menu (**ALL, Ind, noS**) and press *enter* to confirm.

## Navigating the menus:

**esc** – exits the currently programmed parameter without saving changes or takes you to a higher menu level

**prev** – takes to a lower menu lever or reduces the set values

**next** – takes to a higher menu level or increase the set values

**enter** – takes to device programming function and confirms the set values

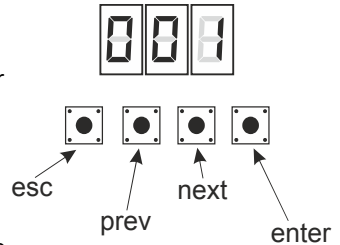

## 4.1 Programming of group parameters

Programming in this menu is common to all channels.

After selecting **ALL** from the main menu, confirm selection by pressing *enter*, then with *next* or *prev* select the parameters to be set:

**Adr** – DMX address of the device

**Cur** – feature of channel dimming

The next step is to confirm selection by pressing *enter*. The address or feature programmed in this way will delete the previous individual settings of the channels.

### 4.1.1 Setting of DMX address

PX227 menu allows to set DMX address of the device in the range from 1 to 505.

In order to set DMX address:

1. Set the **Adr** function
2. By using *next* or *prev* set the selected DMX address. In order to accept the setting, press *enter*.

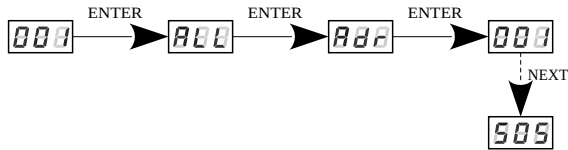

### 4.1.2 Feature of output channels

To adjust the feature for all channels set:

1. From the start menu, go to the group settings menu **ALL**
2. Press *enter* again in order to change the settings for all channels
3. Use *next* to select **Cur**, this will allow to change the characteristic of channel dimming

**Lin** – linear characteristics 0 – 10V

**FLu** – linear characteristics 1 – 10V

**S\_P** – switched characteristics (on / off)

**uSr** – characteristics defined by the user, linear in the range of Min to Max.

Maximum and minimum values can be set in the range from 0 to 10V.

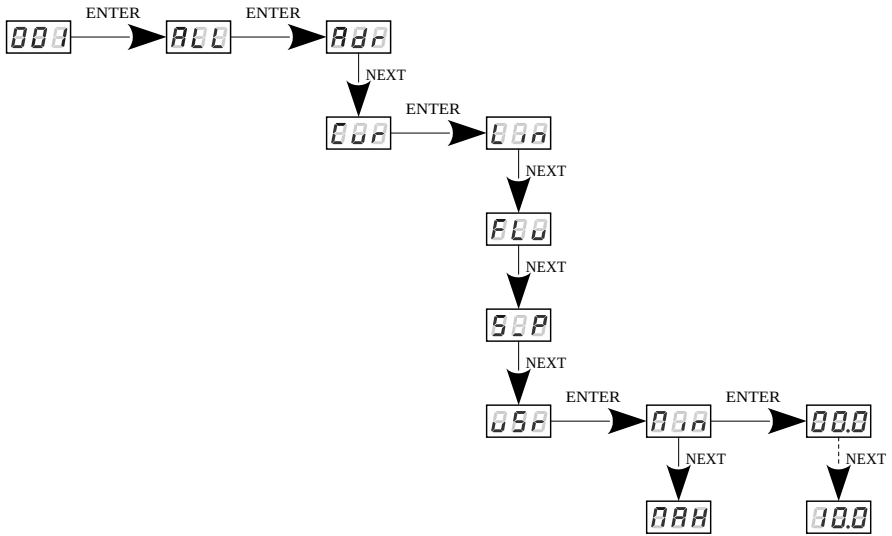

### 4.1.3 Programming of individual parameters

PX227 device has the option of individual settings. It allows to assign each of the eight output channel with any DMX address. It is possible after selecting **Adr**. DMX address can be selected within a range from 1 to 512.

It is also possible to set the output characteristics for each channel.

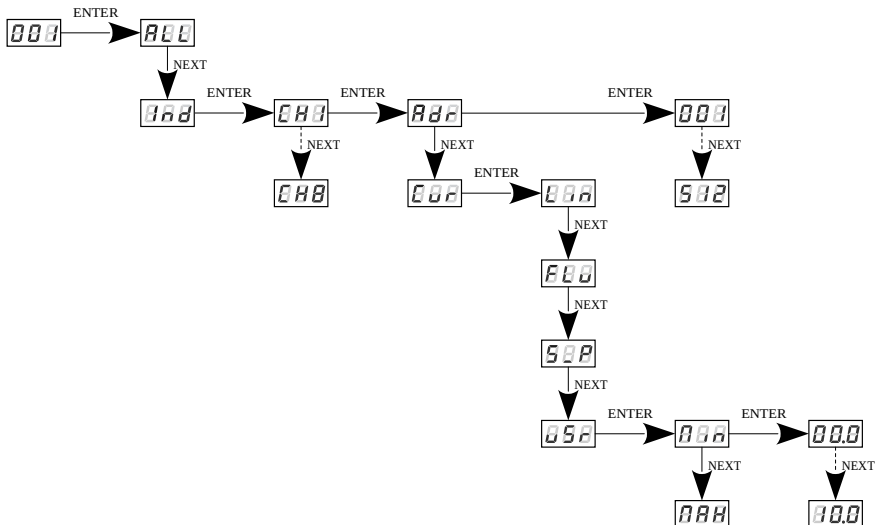



## 4.2 Response to the loss of DMX signal

This function is used both to protect the system against the disappearance of DMX signal and to gain a specific state on outputs. After it has been activated, in case of a lack of DMX signal, the module will perform the selected function by itself. The reconnecting of DMX signal will automatically break the performed function, and the module will again be controlled by DMX signal.

In order to start the function, enter *noS* option:

1. From the start menu go to the *noS* and press *enter*
2. Use the *next* or *prev* buttons to select the device behavior for DMX signal loss

The following options are available:

*Pr1* – *Pr2* – starting program 1 or 2

*on* – switching all outputs on 100%

*oFF* – complete switch-off of outputs

*HLd* – holding the last DMX value

*Sc1* – *Sc4* – scene 1, 2, 3 or 4

Up to 10 steps can be created in the program (*F01* – *F10*), in each step it is possible to define the values of output channels (*CH1* – *CH8*) in the range from 0 to 255. Additionally, in each step you can define its duration (*Spd*) in the range of 0,1 – 99,9 seconds. In the step it is also possible to set the transition smoothness (*FAd*) in the range from 0 (step transition) to 100

(completely fluid transition). It is possible to reduce the number of program steps, for this purpose, for this purpose, in step which should be last and after this step followed first step, select the *on* option in the *End* menu.

In each of the four scenes, you can program the values of each of the eight output channels separately in the range from 0 to 255.

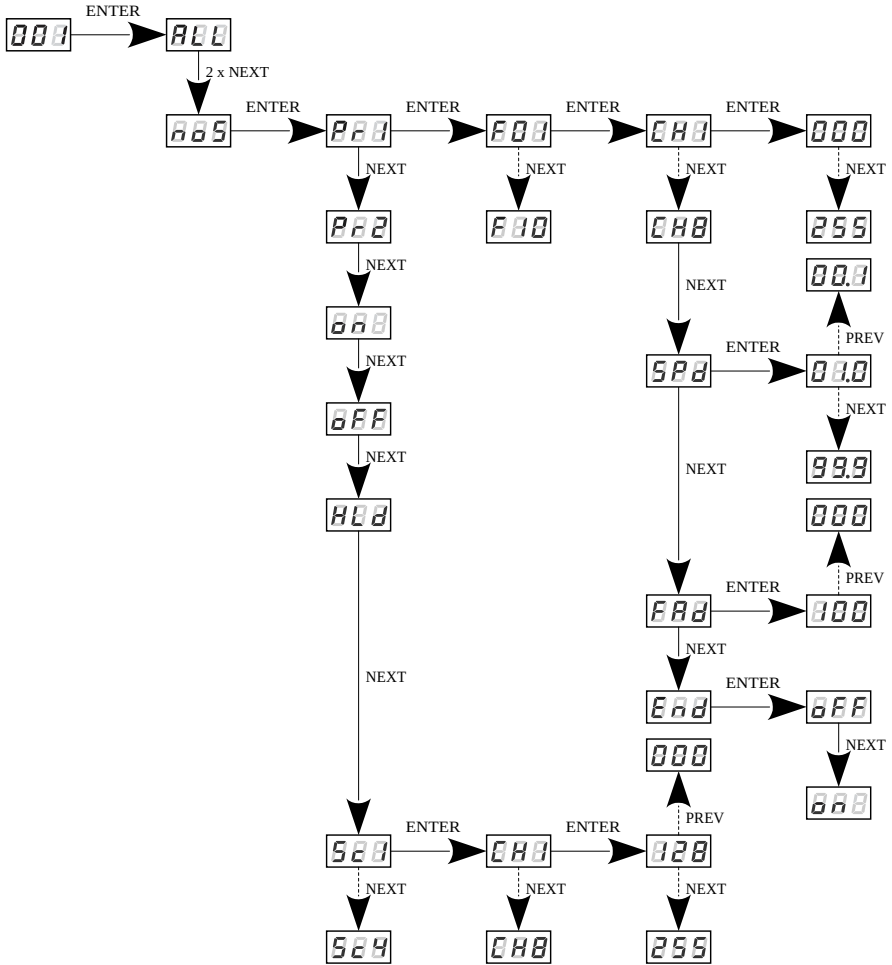

## 4.3 Smoothing function

The device also has the smoothing option. Smoothing allows for smooth color changes. When this option is enabled, switching between successive DMX values sent to channels is smooth, which prevents abrupt changes in voltage.

In order to start the smoothing function, enter the **Sth** option:

1. From the start menu go to the **Sth** settings and press *enter*
2. Use the *next* or *prev* buttons to select the smoothing function and confirm with the *enter* button

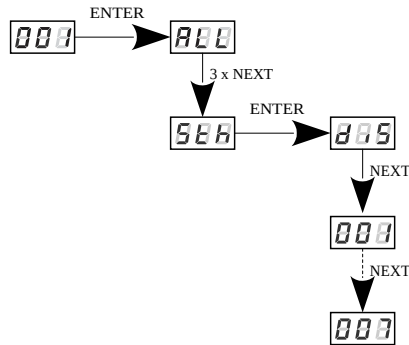

The enabled smoothing function can slightly slow down the device response to the change of DMX signal, so it is possible to switch off this option. In order to switch off smoothing, select **dis** parameter and confirm the selection with *enter*. The range from 1 to 7 are the levels of smoothing.

## 4.4 Screen blanking

The device has been equipped with the option of switching off backlight of the screen. This is provided by the **SCr** option. By using it, the display is switched off approx 60 seconds of inactivity (button unused). The device still operates without interfering with other parameters. Use any button to restore the backlight.

In order to activate the screen blanking function:

1. From the start menu enter the **SCr** settings and press *enter*
2. With *next* or *prev* change the values to **on** and confirm with *enter*

Similarly, you should follow in order to switch off this function, but then selecting **oFF**.

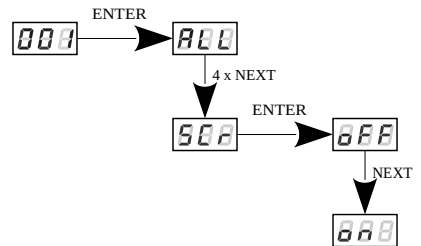

## 4.5 Default settings and device errors

If you have any difficulty accessing the device menu, e.g. it is not possible to enter a particular menu level or it is necessary to restore the device to its default settings, follow the instructions below.

In the first case, when a particular menu level cannot be accessed or menu items are displayed incorrectly, this may indicate that a saving-in-memory error has occurred. In such a case, try to restore the device to its default settings before sending the PX227 to the service center. If, after restoring to its default settings, the device still does not operate correctly, please send it to our service center.

### 4.5.1 Restore default settings

To restore the device to its default settings, press and hold the *previous* key while switching on the device. One of the messages that will be displayed will say **dFI**, which means successful restoring to default settings (the *previous* key has to be held down while powering on the device, until the **dFI** message is displayed).

If this message is accepted by pressing *enter*, the default settings will be restored. The user can also exit this menu level without restoring the default

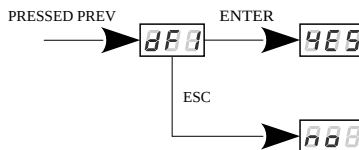

settings. In order to do this, press the escape key.

Please note that after restoring to default settings, all the operating parameters of the device will revert to the following ones:

- **DMX address:** 1
- **no signal:** *oFF*
- **smooth:** *diS* (off)
- **screen saver:** *oFF*

#### **4.5.2 Error message**

The device is equipped with a built-in memory work control function. If there are problems with the memory operation on the PX227 display, the **Err** message appears – memory error.

In this situation, select the *enter* key. The device will reload the default configuration and upload it to the memory. If after this operation, the **Err** message remains on the screen, the memory is permanently damaged and the unit must be sent to the service point.

# 5 Mounting

PX227 is installed on the mounting rail T35 in order to provide stable position and comfortable access to the device.

### Installation on the mounting rail:

1. Set PX227 diagonally to the rail by hooking the two supports on the rear panel of the unit on the upper part of the assembly strip.
2. Pull the latch down using a screwdriver.
3. Attach the device to the rail, still holding a screwdriver in a latch.
4. Release the latch.

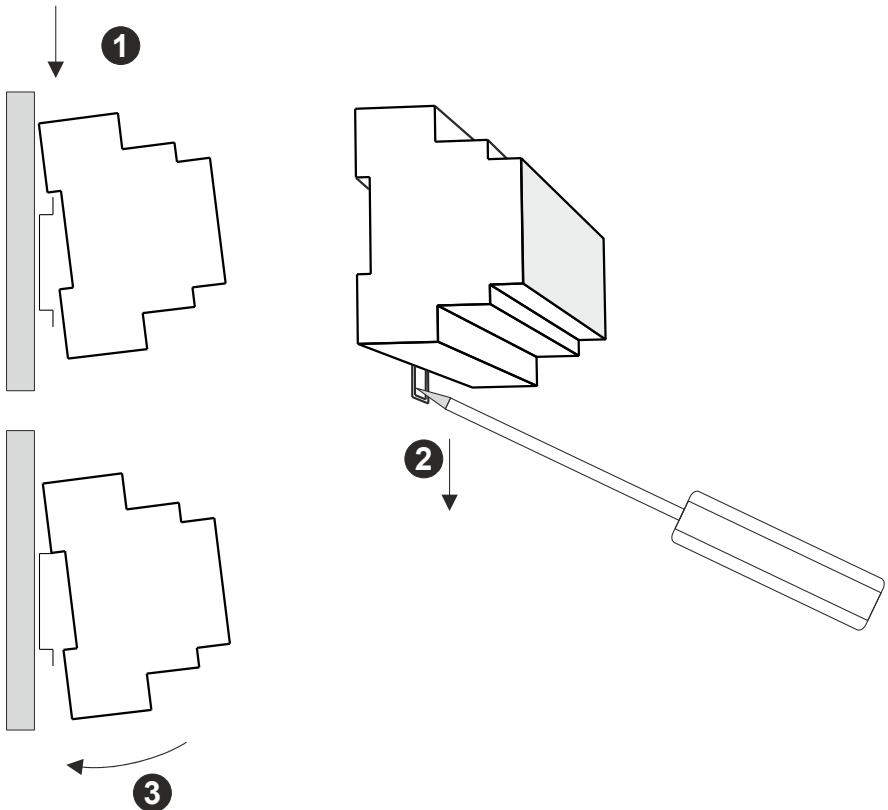





## 7 RDM – available parameters

---

The PX227 supports the DMX – RDM protocol. DMX protocol allows only of a one-way data transmission, while its extension the RDM protocol can transmit information in two directions. This makes possible to simultaneously send and receive information, and hence the possibility of monitoring activities of the compatible devices. Thanks to RDM some available settings of compatible devices may be programmed using this protocol.

### List of supported RDM parameters by PX227:

Parameter name	PiD	Description
SUPPORTED_PARAMETERS	0x0050	all supported parameters
PARAMETER_DESCRIPTION	0x0051	description of additional parameters
DEVICE_INFO	0x0060	information concerning the device
SOFTWARE_VERSION_LABEL	0x00C0	firmware version of the device
DMX_START_ADDRESS *	0x00F0	DMX starting address; Range 1 – 512
IDENTIFY_DEVICE *	0x1000	device identification; Two states are possible: identification disabled (value 0x00) and identification enabled (value 0x01)
DEVICE_MODEL_DESCRIPTION	0x0080	device description, e.g. name
MANUFACTURER_LABEL	0x0081	manufacturer description, e.g. name

Parameter name	PiD	Description
DEVICE_LABEL *	0x0082	additional device description; It is possible to enter an additional device description using up to 32 ASCII characters
FACTORY_DEFAULTS	0x0090	device default settings
PERSONALITY	0x00E0	DMX operational mode
PERSONALITY_DESCRIPTION	0x00E1	description of individual operational modes
SMOOTH_OFF/1/2/3/4/5 *	0x801A	selecting an option for the Smooth function
NO_SIGNAL_OFF/ON/HLD/S *	0x801C	selection of operating mode for no DMX signal
OUTPUT_RANGE_MIN_0-100 *	0x804A	minimum value in the user-defined characteristic, set from 0 to 100
OUTPUT_RANGE_MAX_0-100 *	0x804B	maximum value in the user-defined characteristic, set from 0 to 100
SCREENSAVER_ON/OFF *	0x8024	screen saver setting
SERIAL_NUMBER	0x8030	device serial number
CURVE_0/1/2/3 *	0x8049	setting the characteristics of the output channels (Lin, Fluo, Switch, User)

\* - editable parameter

# 8 DMX signal connecting

PX227 have to be connected to DMX line in serial mode, with no branches on DMX control cable. That means that DMX line, from the signal source, must be connected to **DMX IN** pins of PX227 and later, directly from **DMX OUT** pins to the next device in DMX chain.

If the PX227 is the last DMX chain receiver there should be terminator (resistor 120 Ohm) mounted between "+" and "-" pins of **DMX OUT** section.

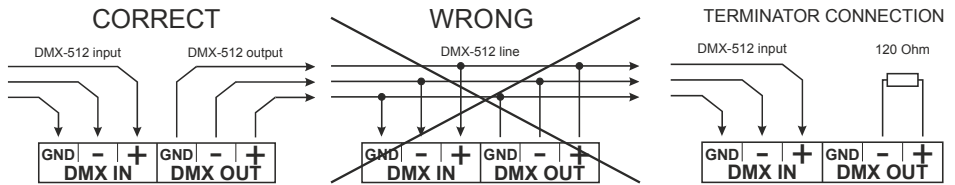

# 9 Connection scheme

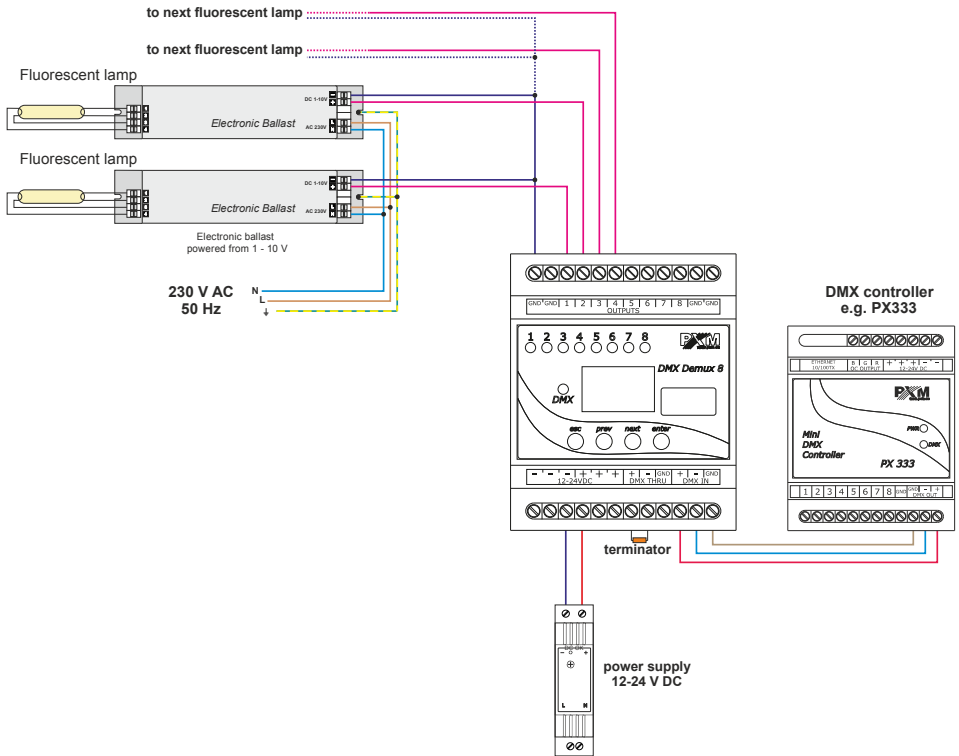

# 10 Dimensions

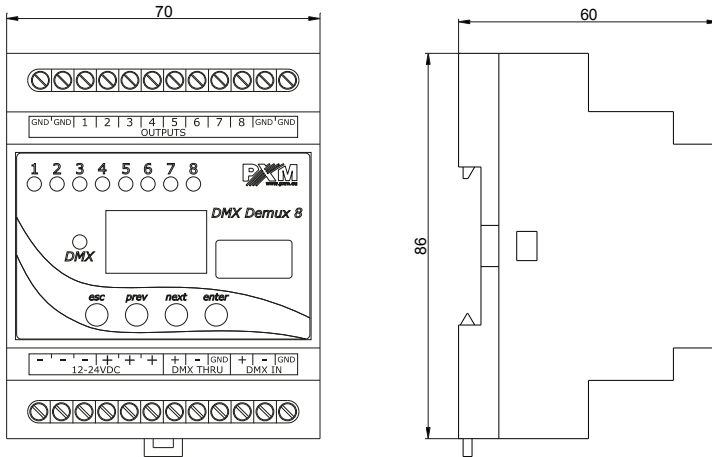

# 11 Technical data

type	PX227
power supply	12 – 24V DC
number of DMX channels	512
RDM protocol	yes (from version 2.06)
number of output channels	8
voltage on outputs	0 – 10V ( $\pm 3\%$ )
output sockets	screw terminals
current consumption	max. 250mA
outputs load	max. 30mA / channel
weight	0.14kg
dimensions	width: 70mm (4 modules) height: 86mm depth: 60mm

## DECLARATION OF CONFORMITY

PXM Marek Żupnik spółka komandytowa  
Podłęże 654, 32-003 Podłęże

we declare that our product:

*Product name:* DMX/0-10V Interface 8ch

*Product code:* PX227

meets the requirements of the following standards, as well as harmonised standards:

PN-EN IEC 63000:2019-01

EN IEC 63000:2018

PN-EN 61000-4-2:2011

EN 61000-4-2:2009

PN-EN IEC 61000-6-1:2019-03

EN IEC 61000-6-1:2019

PN-EN 61000-6-3:2008

EN 61000-6-3:2007

and meets the essential requirements of the following directives:

2011/65/UE **DIRECTIVE OF THE EUROPEAN PARLIAMENT AND OF THE COUNCIL** of 8 June 2011 on the restriction of the use of certain hazardous substances in electrical and electronic equipment  
Text with EEA relevance.

2014/30/UE **DIRECTIVE OF THE EUROPEAN PARLIAMENT AND OF THE COUNCIL** of 26 February 2014 on the harmonisation of the laws of the Member States relating to electromagnetic compatibility (recast)  
Text with EEA relevance.

  
**Marek Żupnik spółka komandytowa**  
32-003 Podłęże, Podłęże 654  
NIP 677-002-54-53



mgr inż. Marek Żupnik.