

PX165

DMX Splitter

MANUAL



CONTENTS

<u>1. General description.....</u>	<u>3</u>
<u>2. Safety conditions.....</u>	<u>3</u>
<u>3. DMX signal connection.....</u>	<u>4</u>
<u>3.1. Exemplary DMX lines.....</u>	<u>4</u>
<u>3.2. The terminator.....</u>	<u>7</u>
<u>3.3. Rules for creating DMX connections.....</u>	<u>7</u>
<u>4. Splitter description.....</u>	<u>7</u>
<u>5. Technical specification.....</u>	<u>8</u>
<u>6. Dimensions</u>	<u>8</u>
<u>Declaration of conformity.....</u>	<u>9</u>

The manufacturer reserves the right to change the operation and handling of the controller in order to improve the product.

1. GENERAL DESCRIPTION

DMX Splitter allows for creating splits in complex DMX installations. According to the requirements of the standard, DMX route must be made by DMX receivers connected in series, creating a chain ended with a terminator. It is not permissible to create splits of this route by simple "splitting on the wire". Sometimes connecting of the receivers in one chain may be very troublesome, in the case of complex installation a possibility of splitting the DMX route with the Splitter has been envisaged, that ensures their proper operation.

The PX165 Splitter allows to split the input DMX signal into 6 independent control branches. Particular output routes are galvanic separated and appropriately strengthened, what guarantees proper operation of the entire installation. Certainly, connection of the receivers to particular output routes must be performed according to the principle of the series chain with a terminator at the end.

Installation of the Splitter is limited to power connection and attachment of the DMX signal cables.

After turning the device on, the input DMX signal is safely multiplied to 6 outputs

The PX165 Splitter is manufactured in a casing for 35 mm DIN rails mounting.

2. SAFETY CONDITIONS

PX165 DMX Splitter is a device powered with safe voltage 12-24 V; however, during its installation and use the following rules must be strictly observed:

1. The device may only be connected to 12-24 V DC (stabilized voltage) with current-carrying capacity compatible with technical data.
2. All the conductors should be protected against mechanical and thermal damage.
3. In the event of damaging any conductor, it should be replaced with a conductor of the same technical data.
4. Connection of DMX signal can only be made with shielded conductor.
5. All repairs and connections of outputs or DMX signal can only be made with cut off power supply.
6. PX165 should be strictly protected against contact with water and other liquids.
7. All sudden shocks, particularly dropping, should be avoided.
8. The device with damaged (cracked) casing cannot be connected to the mains.
9. The device cannot be turned on in places with humidity exceeding 90%.
10. The device cannot be used in places with temperature lower than 2°C or higher than 40°C.
11. Clean with damp duster only.

3. DMX SIGNAL CONNECTION

Frequently, the seemingly faulty operation of DMX devices is caused by their incorrect connection in the DMX network. DMX protocol strictly defines the rules for creating a control installation: below is the drawing of a correct splitting of a DMX route using the splitter.

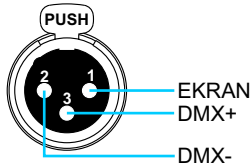

NOTE: The DMX cable shield cannot be connected to the device ground!

3.1. Exemplary DMX line

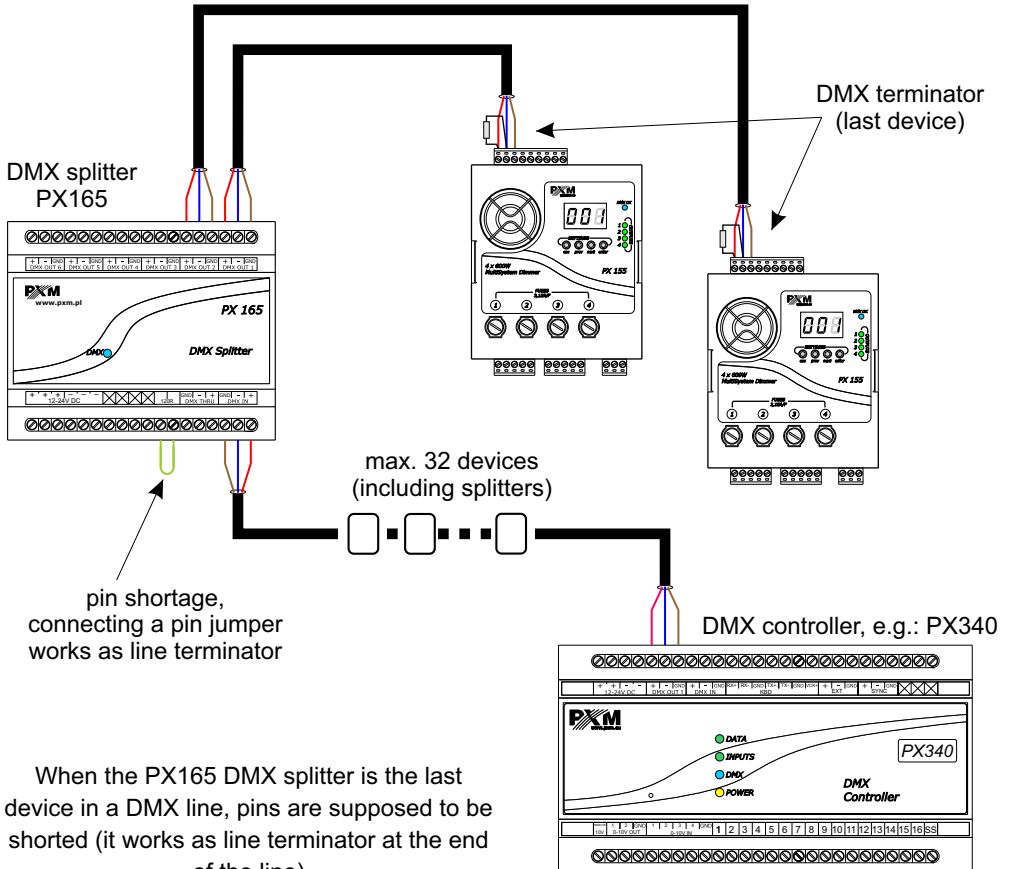

When the PX165 DMX splitter is the last device in a DMX line, pins are supposed to be shorted (it works as line terminator at the end of the line)

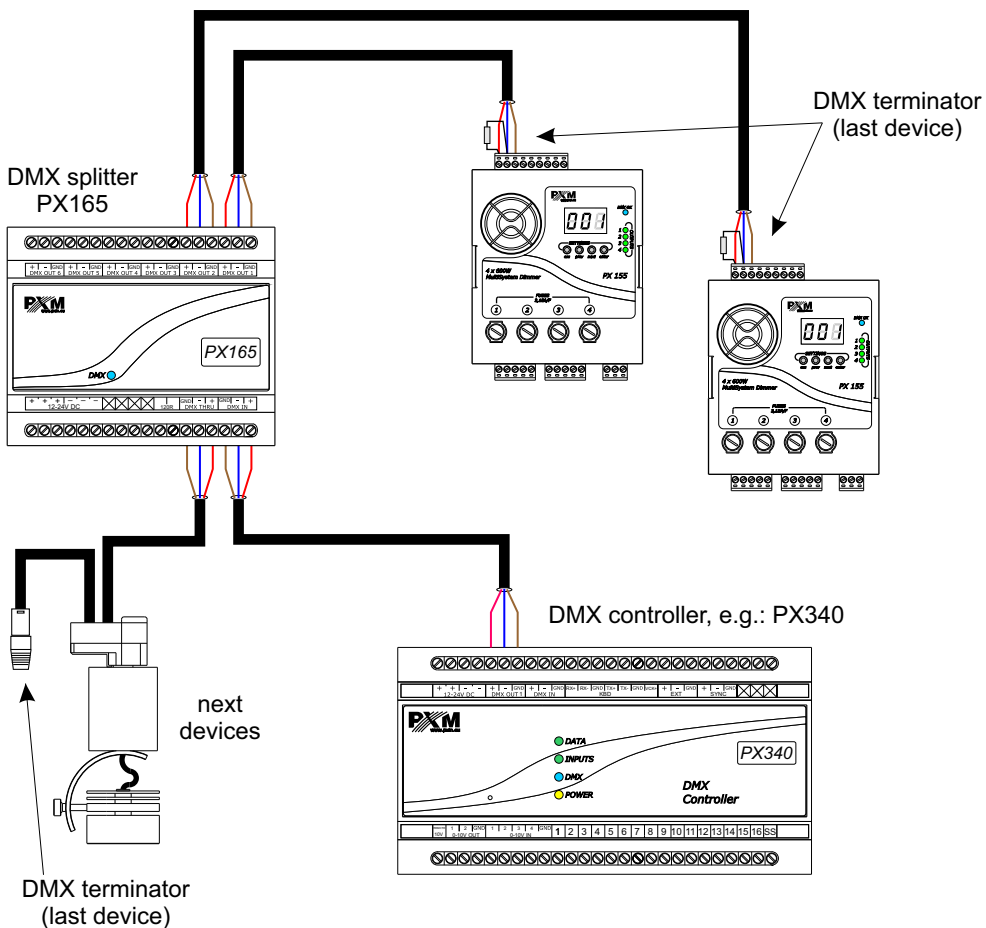

DMX terminator connected in the last device
(120Ω resistor connected between the DMX+ and DMX-)

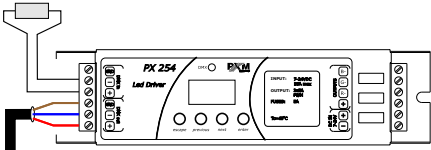

max. 32 devices

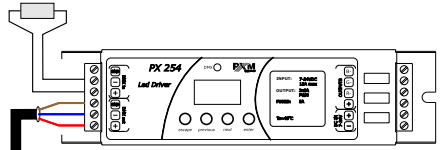
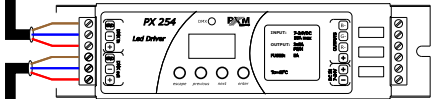
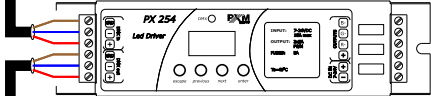

max. 32 devices

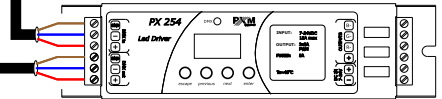
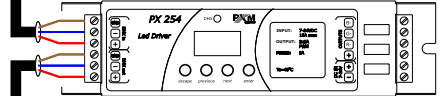

DMX splitter
PX165

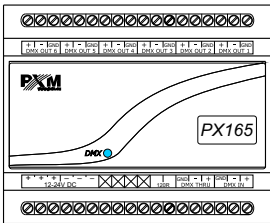

DMX splitter
PX165

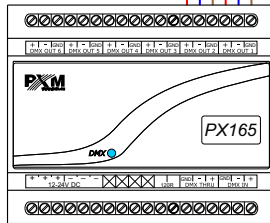

max. 32 devices
(including splitters)

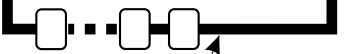

pin shortage,
connecting a pin jumper
works as line terminator

DMX line

DMX controller,
e.g.: PX340

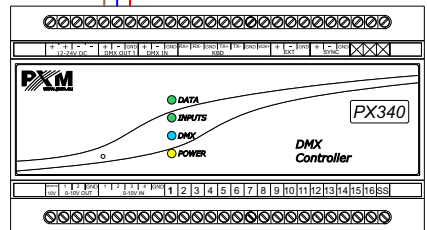

3.2. The terminator

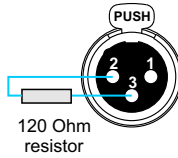

3.3. Rules for creating DMX connections

1. To connect the devices application of the microphone cable is strictly recommended (two strands in a shield).
2. The devices have to be connected in series.
3. When the PX097 repeater is applied, each of two outputs is treated as a beginning of a new DMX line.
4. The maximal number of devices in a DMX line is 32.
5. The maximal length of a DMX line is 500 meters.
6. In the last device of each DMX line between 2nd and 3rd pin of an XLR output socket a terminator (120 Ohm resistor) must be installed.

4. SPLITTER DESCRIPTION

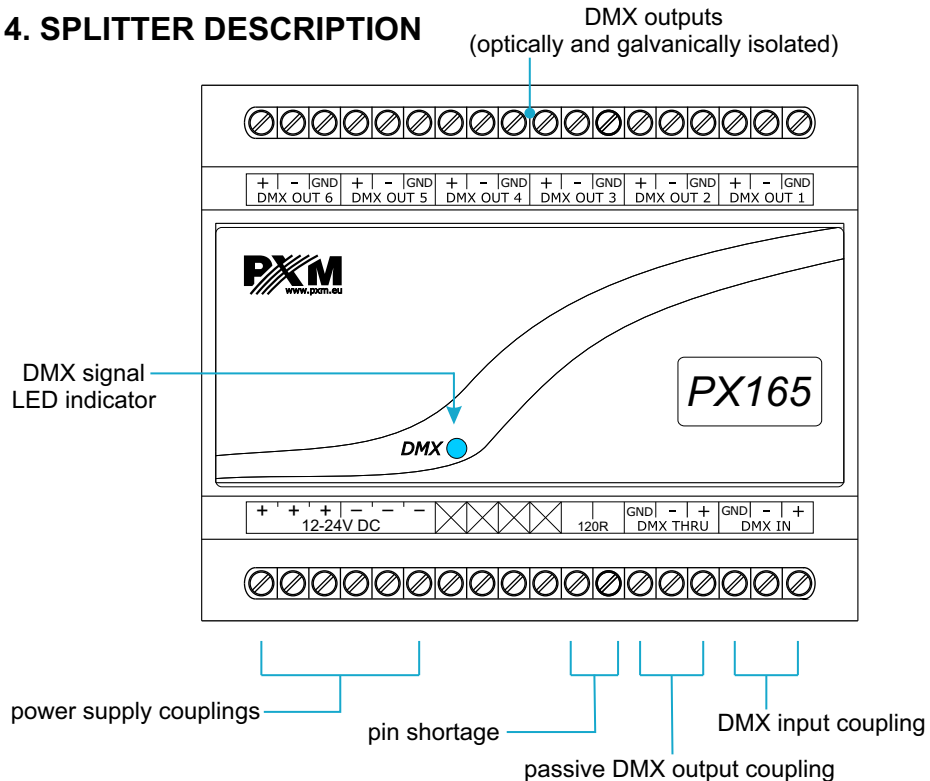

The blue LED (DMX signal indicator) on the front panel of device after connecting power supply blinks two times. When the PX165 does not receive any DMX signal it blinks once every 3 seconds. In case of receiving DMX signal it blinks every 0.5 second.

5. TECHNICAL SPECIFICATION

- DMX line optical isolation yes (1000 V VDC)
- DMX signal input clamping screws
- DMX signal outputs clamping screws
- power supply 12-24 V DC
- current consumption 500 mA max.

- dimensions:

- width 105 mm
- height 86 mm
- depth 60 mm

Note: Starting from device with serial number 13030326 power supply voltage range of 12V DC has been extended to 12-24V DC.

6. DIMENSIONS

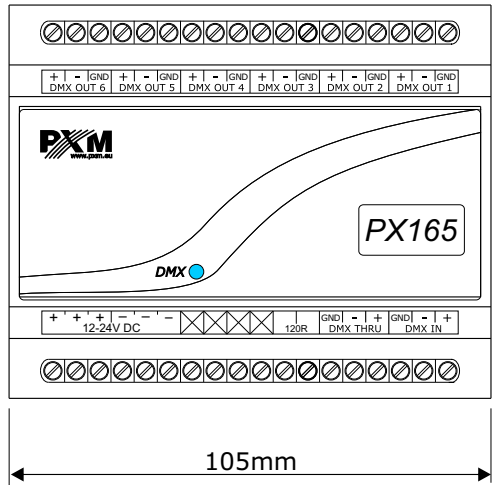
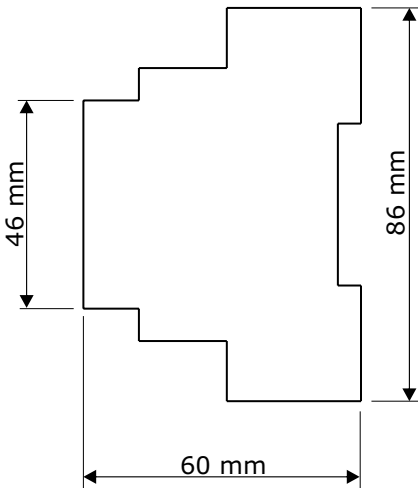



ul. Przemysłowa 12
30-701 Kraków, Poland

tel: +48 12 626 46 92
fax: +48 12 626 46 94

e-mail: info@pxm.pl
<http://www.pxm.pl>

DECLARATION OF CONFORMITY

according to guide lines 2004/108/EC and 2006/95/EC

Name of producer: PXM Marek Żupnik spółka komandytowa

Manufacturer's address: ul. Przemysłowa 12
30-701 Kraków, Poland

We declare that our product:

Product name: **DMX Splitter**

Product code: **PX165**

complies with the following standards:

LVD: PN-EN 60065:2004

**EMC: PN-EN 55103-1:2012
PN-EN 55103-2:2012**

Additional information:

The DMX-512 output must be shielded and the shielding must be connected to the ground responding to the DMX connectors.



Marek Żupnik spółka komandytowa
30-701 Kraków, ul. Przemysłowa 12
NIP 677-002-54-53

Kraków, 16.04.2012

mgr inż. Marek Żupnik (M.Sc. Eng.)