

PX155

# MultiSystem Dimmer

4 x 600W

User manual



# Table of Contents

1 Description.....	4
2 Safety conditions.....	5
3 Connectors and control elements.....	7
4 Designation of displayed messages.....	7
5 Dimmer programming.....	9
6 Programmable parameters.....	9
6.1 Digital input settings.....	10
6.1.1 Group parameters.....	11
6.1.2 Individual parameters.....	12
6.1.3 Temperature.....	13
6.1.4 Input control mode.....	13
6.1.5 Scenes and chaser programming.....	13
6.2 Analog input settings.....	14
6.2.1 Group parameters.....	14
6.2.2 Individual parameters.....	15
6.2.3 Temperature.....	16
6.2.4 Input mode.....	16
6.3 Function diagrams for external button control.....	17
6.3.1 Function one.....	17
6.3.2 Function two.....	17
6.3.3 Function three.....	18
6.3.4 Function four.....	18
6.3.5 Function five.....	19
7 Dimmer access lock.....	20
7.1 Switching the access lock on.....	21
7.2 Switching the access lock off.....	21
8 Menu scheme for digital input.....	23
9 Menu scheme for analog input.....	24
10 Assembly of the device.....	25
11 Connection scheme.....	26
11.1 DMX-512 signal control.....	27

11.2 Control of linear potentiometers.....	28
11.3 0 – 10V control.....	29
11.4 Monostable buttons control.....	30
12 Dimensions.....	31
13 Notes.....	31
14 Technical data.....	32

Manufacturer reserves the right to make modifications in order to improve device operation.

PXM Marek Żupnik sp.k.  
Podłęże 654  
32-003 Podłęże  
BDO register number 000005972

tel. +48 12 385 83 06  
mail: [info@pxm.pl](mailto:info@pxm.pl)  
[www.pxm.pl](http://www.pxm.pl)

Rev.1-6  
13.05.2019

# 1 Description

---

Professional digital dimmer designed for fixed installations.

The device depending on the model allow to control four or two independent circuits of 600W or 1200W loads each. It has built-in interference suppression system, signal lights, fuses, DMX-512 control and 0 – 10V input. There are also external control keys available that work in accordance with one of four built-in functions.

Programmable parameters for all channels:

- DMX start address of the first channel
- control characteristics (linear, linear inverse, logarithmic, exponential, switched ON / OFF, three neon control characteristics)
- ACL – limiting the output voltage in the range of 50 – 230V with an accuracy of up to 1V
- Preheat – bulb preheating (0 – 10%)
- dimmer reaction to DMX signal loss (off, on 100%, slow shutdown, last DMX value, one of three scenes or one of two chasers)

Individually programmable parameters for each channel:

- DMX address (from 1 to 512) – each channel can be ascribed to a different DMX address or both channels can even have the same address
- one of eight control characteristics
- limiting the output voltage in the range of 50 – 230V with an accuracy of up to 1V

The control is possible by means of: DMX-512 digital signal, analog signals 0 – 10V or using external keys.

## 2 Safety conditions

---

PX155 dimmer is powered directly from standard 230V grid, what can cause electric shock when safety rules are not observed. Therefore it is necessary to observe the following:

1. Installation, particularly power connection, should be performed by a person holding the appropriate qualifications, according to the description in the instruction manual.
2. Dimmer can be connected to socket which has protection installation – separate PE strand – in working order only (3-strand grid).
3. All the conductors should be protected against mechanical and thermal damage.
4. In the event of damaging any conductor, it should be replaced with a conductor of the same technical data and attestation.
5. The external devices can be connected to the dimmer with 3-strand 1.5mm minimum cross-section area only.
6. Dimmer can be installed in close electrical switching stations only, with restricted access for people who does not handle proper qualifications in 230V supplied devices maintenance.
7. Power input must be protected with an external residual current breaker with overload of 10A rated current and C-type characteristics.

8. After the installation is completed, check the neutralization efficacy of all powered devices.
9. All repairs demanding casing opening should be made with cut off power supply.
10. The device should be strictly protected against water and other liquids.
11. All sudden shocks, particularly dropping, should be avoided.
12. Device with damaged (bent) casing should be not connected to the mains.
13. The device cannot be turned on in places with humidity exceeding 90%.
14. The device cannot be used in places with temperature lower than +2°C or higher than +40°C.

#### **NOTE!**

1. Improper connection of the protective wire can cause electric shock.
2. Improper connection of the neutral conductor will cause the dimmer to malfunction.
3. The dimmer can control resistive and inductive circuits (loads) only.

The dimmer cannot be used to control the electronic transformers, electronic ballasts for fluorescent lamps and other devices that have electronic circuits, unless the producer distinctly states so.

### 3 Connectors and control elements

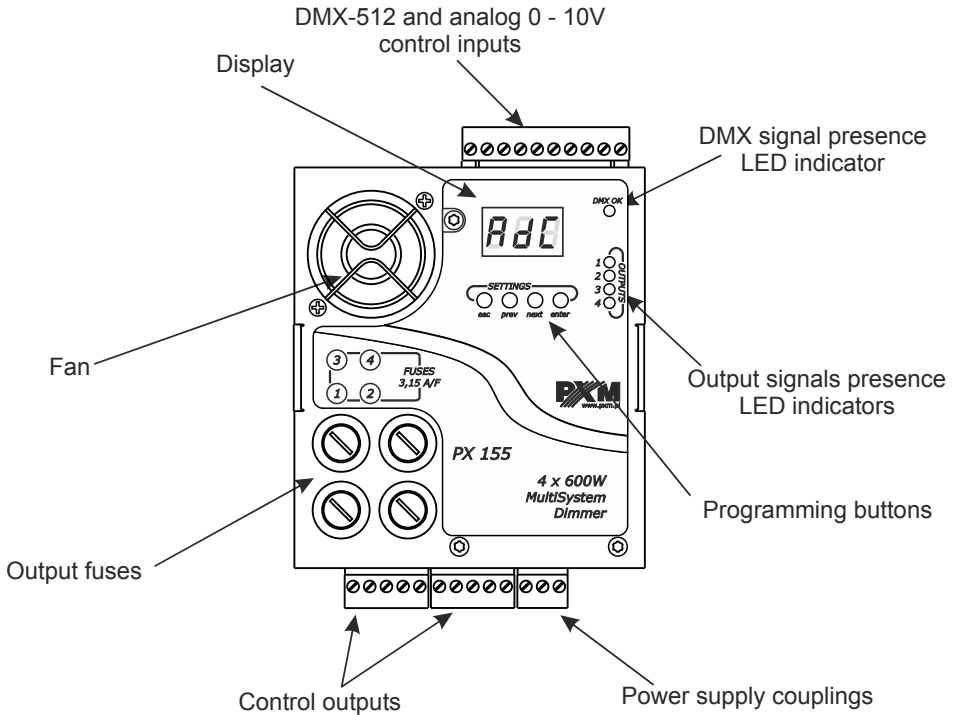







### 4 Designation of displayed messages

- No DMX signal: slow dimming of all outputs
- Minimal brightness of a particular channel show in percentage (%)
- Maximal brightness of a particular channel show in percentage (%)
- Limit – output voltage limitation in a range from 50 to 230V
- DMX address selected in a range from 1 – 509
- Group parameters
- C01 – C04, number of the edited channel

<b>0BF</b>	Built-in factory chaser (in addition – reaction to DMX signal loss)
<b>0BP</b>	Programmable chaser (in addition – reaction to DMX signal loss)
<b>0BF</b>	Characteristics, 6 different characteristics to choose from
<b>BEF</b>	Scenes and chasers programming
<b>EBP</b>	Exponential characteristics
<b>F04</b>	F01 – F04, numbers of the edited scenes
<b>FAB</b>	XFade switching on / off (for scene smooth changing)
<b>AAA</b>	Analog input 0 – 10V
<b>FBA</b>	Control function for external button
<b>BA5</b>	Brightness rising time for button control
<b>BB0</b>	Dimmer internal temperature
<b>BEA</b>	Number of chaser steps – available values from 1 to 8
<b>HBB</b>	No DMX signal – recently controlled values maintaining
<b>BBB</b>	Individual programming parameters
<b>0AA</b>	Linear characteristic
<b>0AV</b>	Logarithmic characteristic
<b>0AB</b>	Inverted characteristic
<b>AE0</b>	nE1 – nE3, for neon lamps control characteristics
<b>ABS</b>	No signal – device reaction to DMX signal absence or interruption (9 possibilities to choose from)
<b>00A</b>	No signal – all outputs controlled at 100%
<b>00F</b>	No signal – all outputs turned off
<b>PBE</b>	Preheat – bulb's filaments preheating, set in a range from 0 to 10%
<b>SE0</b>	Sc1 – Sc4, programmable scenes (set also in case of DMX signal absence or interruption)
<b>SP0</b>	Chaser speed in a range from 001 to 032
<b>SP0</b>	Switchable characteristic



	Switching the input mode (digital / analog)
	External button control
	Control function executed with external button no. 1
	Maximum brightness duration time for button control
	Temperature sensor fail – contact service for repair
	Analog mode – selecting this option in the main menu activates analog control mode (also in the <i>noS</i> mode)

## 5 Dimmer programming

---

After turning the device on, software version is shortly displayed. During the device normal operation the display shows DMX address or displays **AdC** lettering, meaning analog control mode. Pressing **Esc** during normal operation will test the display – all the segments should get **On** state. Press **Enter** to switch to the main menu, the display will show **ALL**. Press **Prev** or **Next** to select programming menu (**ALL**, **Ind**, **AdC**, **dEF**), and then press **Enter** to confirm your selection.

## 6 Programmable parameters

---

The parameters you can program for the dimmer include:

1. Group parameters – **ALL** – settings are the same for all the channels. For DMX address setting it means that address displayed is the address of the first channel. Programming DMX address in this menu deletes the previously programmed individual addressing.

2. Individual parameters – **Ind** – each channel may be set with individual parameters, including individual DMX addressing. The same address may be set to more.

*Group parameters have a higher priority than individual parameters.*

*This means that programming in the **ALL** mode, for example, the DMX address, cancels the previous settings for all channels.*

3. Dimmer temperature – **°C** – the function to check out the internal dimmer temperature.
4. Analog / digital mode of operation switching – **AdC** – the function to switch between digital control mode (DMX) or analog control (0 – 10V signal or monostable external button).
5. Scenes and chasers programming – **dEF** – active only with the digital control mode (so the parameter **AdC** set to **OFF**).

The function allows:

- 3 scenes programming
- 4 user-defined chaser steps with speed and fading options programming
- speed and fading of built-in chaser

## 6.1 Digital input settings

Digital input (so controlling the dimmer with DMX-512 signal) is active when parameter **AdC** is set to **OFF**.

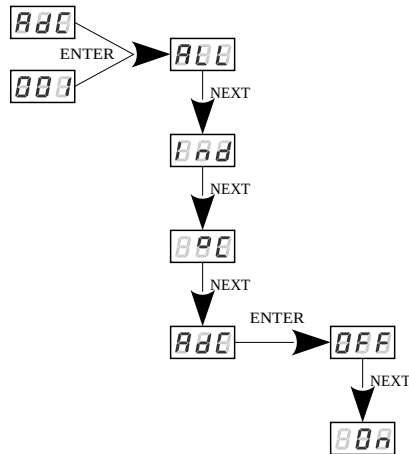

### 6.1.1 Group parameters

1. **Adr** – DMX address from the range 1 to 509 (setting 509 as the address for the first channel means automatically address 512 for the fourth dimmer channel).
2. **Cur** – characteristic, there are 9 options to choose from:
  - **Lin** – linear
  - **SP** – switchable
  - **Inu** – inverted
  - **LnU** – logarithmic
  - **E\_P** – exponential
  - **nE1 ... nE3** – for neon lamps control \*
  - **Li2** – linear 15 – 100% (zero value at the power output for DMX values of 0 – 15%)
3. **ACL** – limits the output voltage in the range from 50 – 230V
4. **PrE** – heating up the bulb filaments, set in the range from 0 – 10%
5. **FSo** – dimmer wake up after power supply connection

6. **noS** – precise the dimmer reaction to DMX signal interruption. There are 11 options to choose from:
- **On** – turning all outputs on at 100%
  - **OFF** – turning all outputs off
  - **HLd** – the last received value is held
  - **222** – slow output switching off (about 20 seconds)
  - **Sc1 ... Sc4** – programmable scenes
  - **CrF** – built-in chaser
  - **CrP** – user-defined chaser
  - **AnL** – analog mode activation in the absence of DMX (e.g. it allows to control using the connected external momentary buttons)

### 6.1.2 Individual parameters

1. **Adr** – DMX address from the range 1 to 512
2. **Cur** – characteristic, there are 9 options to choose from:
  - **Lin** – linear
  - **SP** – switchable
  - **Inu** – inverted
  - **LnU** – logarithmic
  - **E\_P** – exponential
  - **nE1 ... nE3** – for neon lamps control \*
  - **Li2** – linear 15 – 100% (zero value at the power output for DMX values of 0 – 15%)
3. **ACL** – limits the output voltage in the range from 50 – 230V

### 6.1.3 Temperature

°C – this parameter allows to check the dimmer internal temperature in the range -40 to +125°C.

**NOTE!** Message *Er1* means sensor failure, so service is necessary.

### 6.1.4 Input control mode

*AdC* – switching between default digital control mode (DMX-512, setting *OFF*) and analog mode (0 – 10V control signal or external button – setting *On*).

### 6.1.5 Scenes and chaser programming

1. *Sc1* ... *Sc4* – scenes programming:
  - *C01* ... *C04* – edited channel number
    - *0* ... *100* – channel brightness in percentage %
2. *CrP* – user-defined chaser:
  - *F01* ... *F08* – editable pattern numbers
    - *C01* ... *C04* – edited channel number
      - *0* ... *100* – channel brightness in percentage %
  - *LEn* – chaser step number (1 to 8)
  - *SPd* – chaser speed from 1 (255 seconds) to 32 (0.1 second)
  - *FAd* – scenes fading function switching on or off
3. *CrF* – built-in chaser:
  - *SPd* – chaser speed from 1 (255 seconds) to 32 (0.1 second)
  - *FAd* – scenes fading function switching on or off

## 6.2 Analog input settings

Analog input from smooth 0 – 10V control or monostable button control is active with the parameter **AdC** set to **On**.

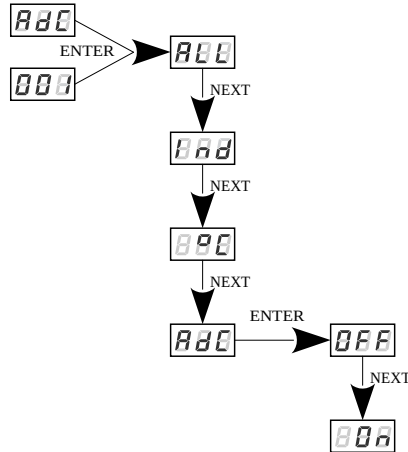

### 6.2.1 Group parameters

1. **Aln** – detailed settings for analog control input:
  - **AnL** – voltage control 0 – 10V (for 0V total dimming, for 10V maximum brightness) using a 10kΩ linear potentiometer or an external control voltage
  - **bln** – settings for external monostable button control:
    - **Fun** – 5 functions to choose from (see charts in item 6.3)
    - **rIS** – brightness rising time to maximum allowed by output **ACL** voltage – from 0 (immediately) to 255 seconds
    - **LAS** – duration time from 0 to 9990 seconds
2. **Cur** – characteristic, there are 9 options to choose from:
  - **Lin** – linear
  - **SP** – switchable

- **Inu** – inverted
  - **LnU** – logarithmic
  - **E<sub>P</sub>** – exponential
  - **nE1 ... nE3** – for neon lamps control \*
  - **Li2** – linear 15 – 100% (zero value at the power output for DMX values of 0 – 15%)
3. **ACL** – limits the output voltage in the range from 50 – 230V
  4. **PrE** – heating up the bulbs filaments, set in range from 0 – 10%
  5. **FSo** – dimmer wake up after power supply connection

## 6.2.2 Individual parameters

1. **AIn** – analog control input settings for each channel:
  - **AnL** – voltage control 0 – 10V (for 0V total dimming, for 10V maximum brightness) using a 10kΩ linear potentiometer or an external control voltage
  - **bln** – settings for monostable external button:
    - **Fun** – 5 functions to choose from (see charts in item 6.3)
    - **rIS** – brightness rising time to maximum allowed by output **ACL** voltage – from 0 (immediately) to 255 seconds
    - **LAS** – duration time from 0 to 9990 seconds
2. **Cur** – characteristic, there are 9 options to choose from:
  - **Lin** – linear
  - **SP** – switchable
  - **Inu** – inverted
  - **LnU** – logarithmic

- ***E\_P*** – exponential
  - ***nE1 ... nE3*** – for neon lamps control \*
  - ***Li2*** – linear 15 – 100% (zero value at the power output for DMX values 0 – 15%)
3. ***ACL*** – limits the output voltage in the range from 50 – 230V

### 6.2.3 *Temperature*

**°C** – this parameter allows to check the dimmer internal temperature in the range -40 to +125°C.

**NOTE!** Message ***Er1*** means sensor failure, so service is necessary.

Dimmer has been equipped with thermal protection with the following settings for the temperatures inside the dimmer:

- 60°C – automatic start of the electronically controlled fan
- 90°C – 10% drop in power output and 10% more with each subsequent 1°C
- 100°C – automatic switch-off of the dimmer

After cooling and lowering the temperature to 70°C, the device starts working again at full power.

### 6.2.4 *Input mode*

***AdC*** – switching between default digital control mode (DMX-512, setting ***OFF***) and analog mode (0 – 10V control signal or external button – setting ***On***).



## 6.3 Function diagrams for external button control

### 6.3.1 Function one

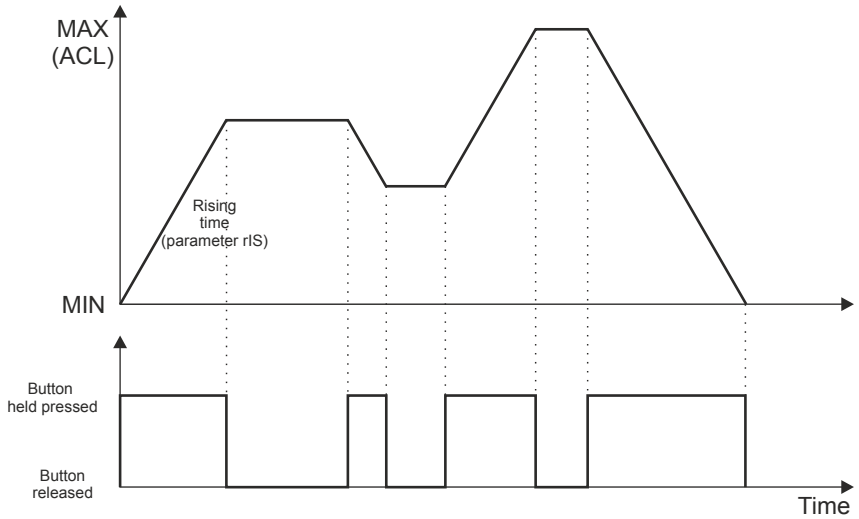

### 6.3.2 Function two

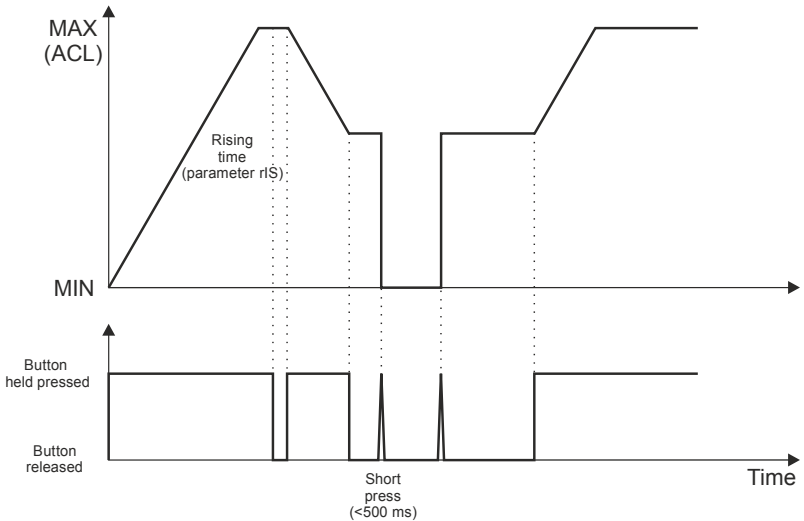

### 6.3.3 Function three

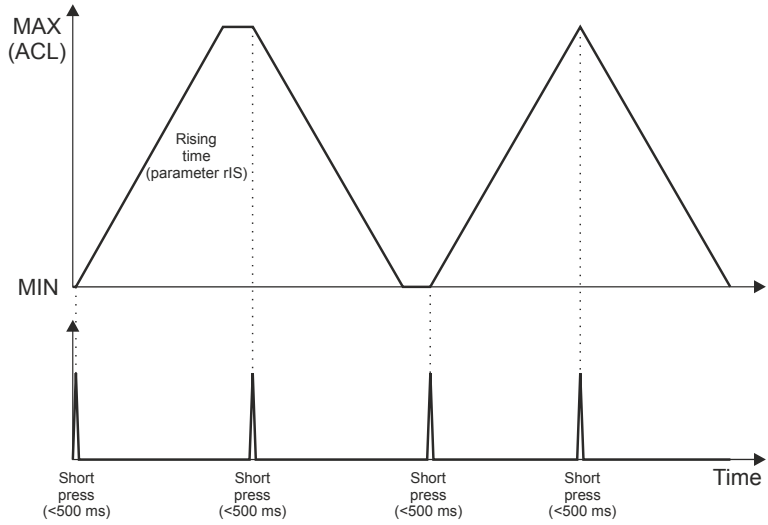

### 6.3.4 Function four

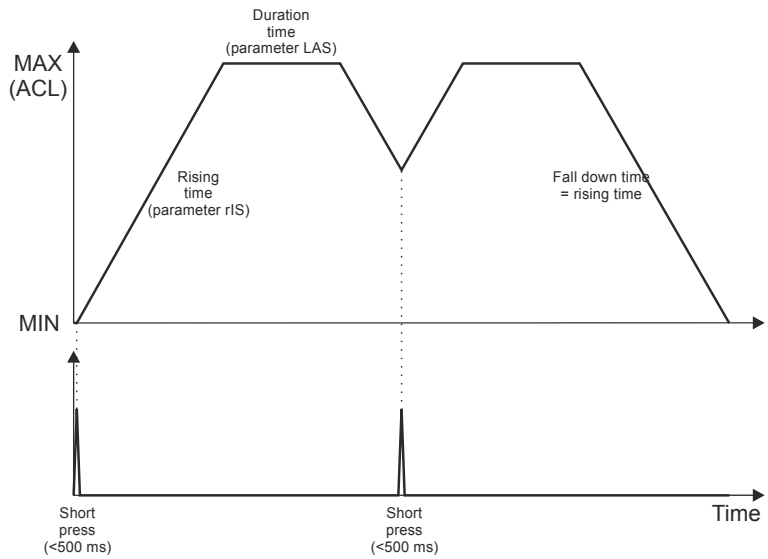

Each subsequent short press of a key, when the function performs the **LAS** parameter, causes the parameter time to be counted from 0 (reset the elapsed time). The value of this parameter is taken into account only in the fourth function. The other three are ignored.

### 6.3.5 Function five

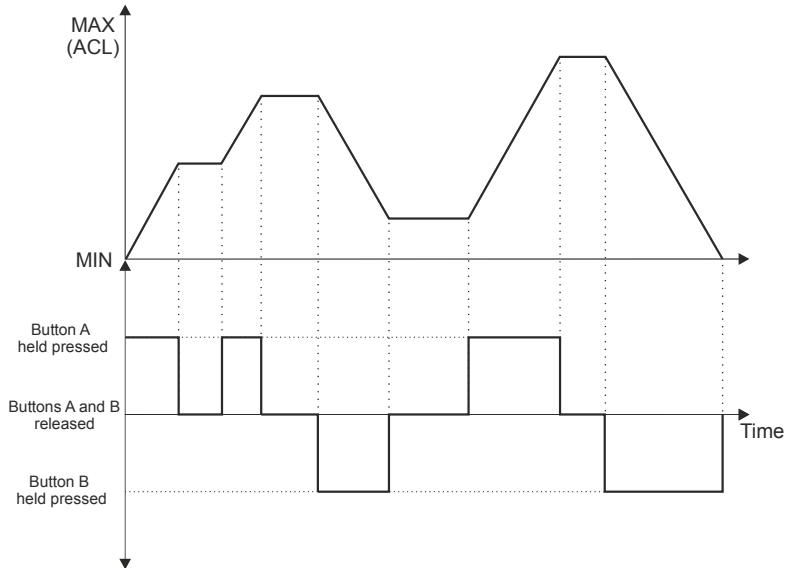

Pressing and holding the external button "A" causes rise of the brightness. Once it is released the brightness stops to increase. Pressing and holding the external button "B" leads to the brightness fall down. After releasing the button "B" brightness will remain at the same level as at the time of its release.

**NOTE!** To use this function additional resistor should be installed before external button "B" (as in the schematic diagram below).

## REFLECTORS

max. 4 x 600W

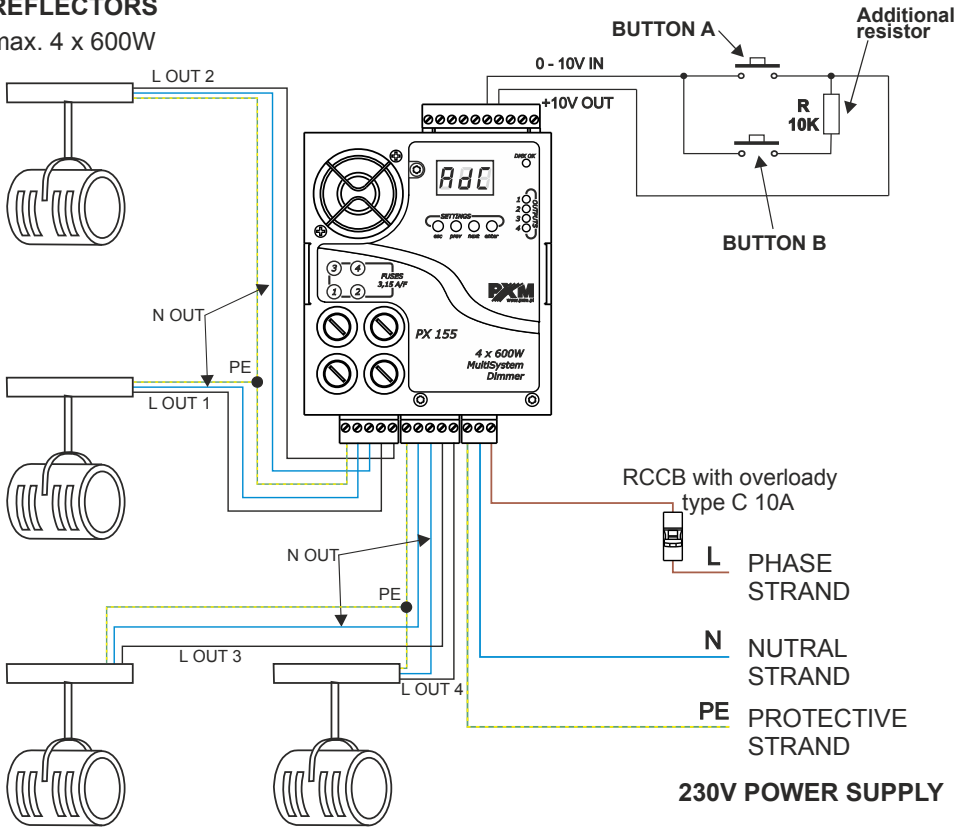

## 7 Dimmer access lock

According to expanded possibilities of dimmer parameters settings there is option to code programming effects (programmer-defined number from range 1 to 255). Such situation other users can only read defined parameters without possibility of modification. With the parameters coded also function *dEF* is not displayed.

## 7.1 Switching the access lock on

1. Press **Esc** enough times to leave dimmer programming mode – the display will show finally DMX address. Then press and hold **Esc** and press **Next** – the display will answer with **PAS** lettering. Release **Esc** key.
2. Press **Enter**. The display will show **Enb**. (If **dSb** appears dimmer is already code protected – see point 7.2).
3. Once again press **Enter** and choose the password with **Next** or **Prev** keys. Confirm decision with **Enter**.
4. The dimmer is code protected. It will automatically terminate locking procedure and return to programmed operation.

## 7.2 Switching the access lock off

1. Press **Esc** enough times to leave dimmer programming mode – the display will show finally DMX address. Then press and hold **Esc** and press **Next** – the display will answer with **PAS** lettering. Release **Esc** key.
2. Press **Enter**. Then display will show **dSb**. (If **Enb** appears dimmer is not code protected – see point 7.1).
3. Once again press **Enter** and the display will show **127**. Set user-defined password with **Prev** or **Next** keys. Confirm correct number with **Enter**.
4. The dimmer password is removed and all programmable parameters are unlocked. Dimmer will automatically return to standard operation.

**NOTE!** Confirming the wrong password will display **bAd**. It is necessary to start unlocking procedure from beginning. The third time wrong password setting lock the dimmer permanently, displaying **Loc**. The telephone contact to service is necessary to reset the password.







# 10 Assembly of the device

View of the back of the device

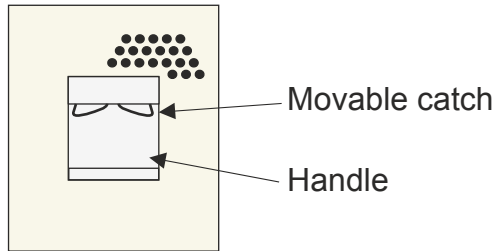

On the back of the device there is a handle with a movable catch, which enables quick and convenient placement of the device on the T35 mounting rail.

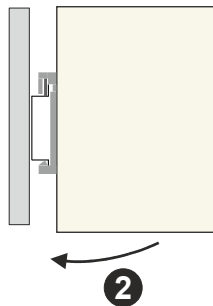
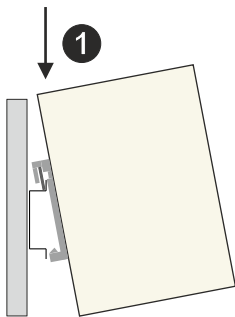

To install the device, it should be applied to the rail as shown in the figure on the left, then hook the movable hook to the upper edge of the rail. The next step is to push the device down so that the lower part of the holder on the bottom edge of

the rail can be inserted.

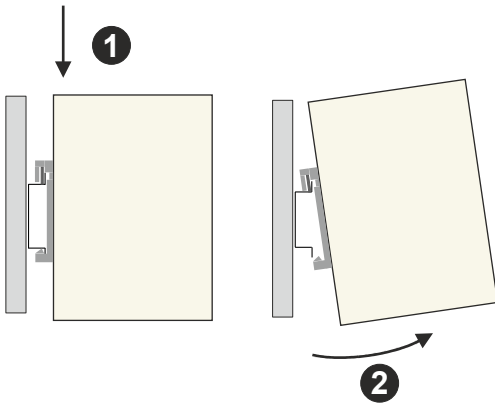

To remove the device, press it from the top, and then tilt the bottom of the device towards you. Finally, moving the whole device up slightly can be removed.

## 11 Connection scheme

MultiSystem Dimmer must be connected to the DMX line in series. That means, the control cable must be driven to the DMX coupling of the dimmer, and then driven out from the same coupling (refer to the scheme below) to the next DMX-512 signal receivers.

If MultiSystem Dimmer is installed as the last device in a DMX line, a terminator (120 Ohm resistor) must be connected to “DMX+” and “DMX-” terminals.

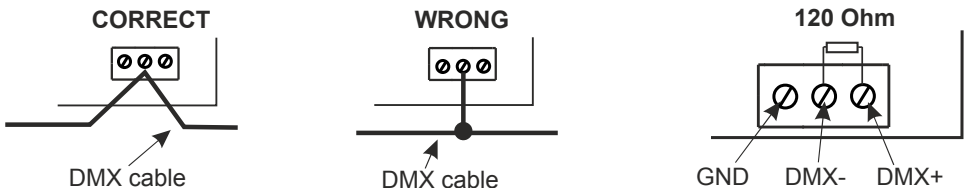

In addition, when, instead of potentiometers, the monostable button is to be applied, it must be connected to “+10V OUT” and “0 – 10V IN” inputs.

# 11.1 DMX-512 signal control

## REFLECTORS

max. 4 x 600W

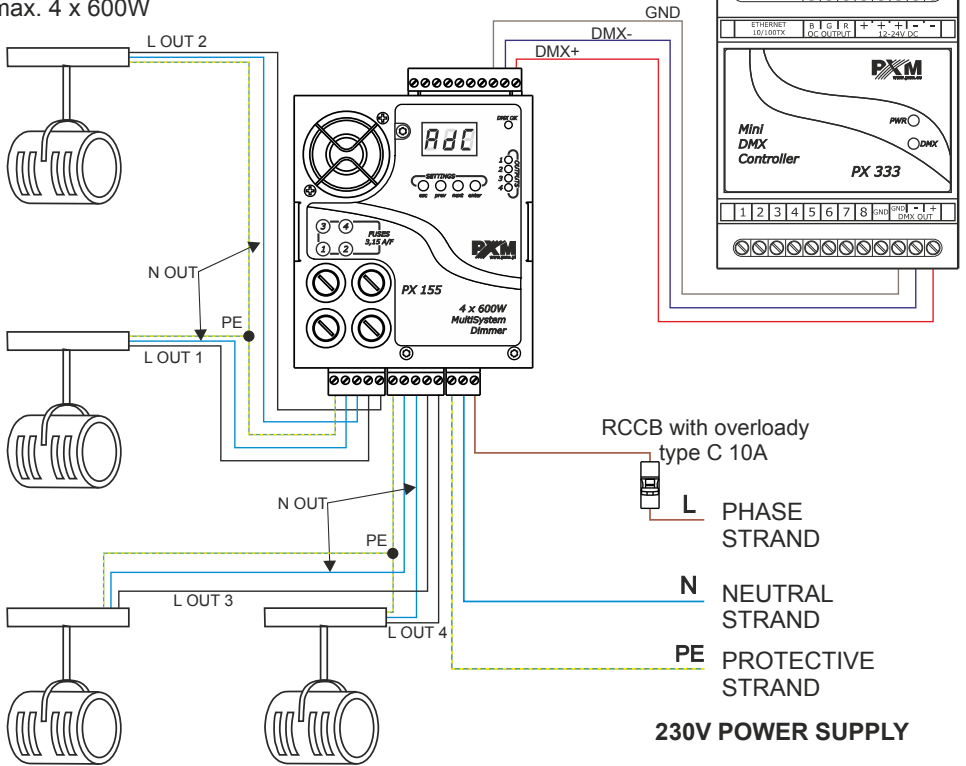

**230V POWER SUPPLY**

# 11.2 Control of linear potentiometers

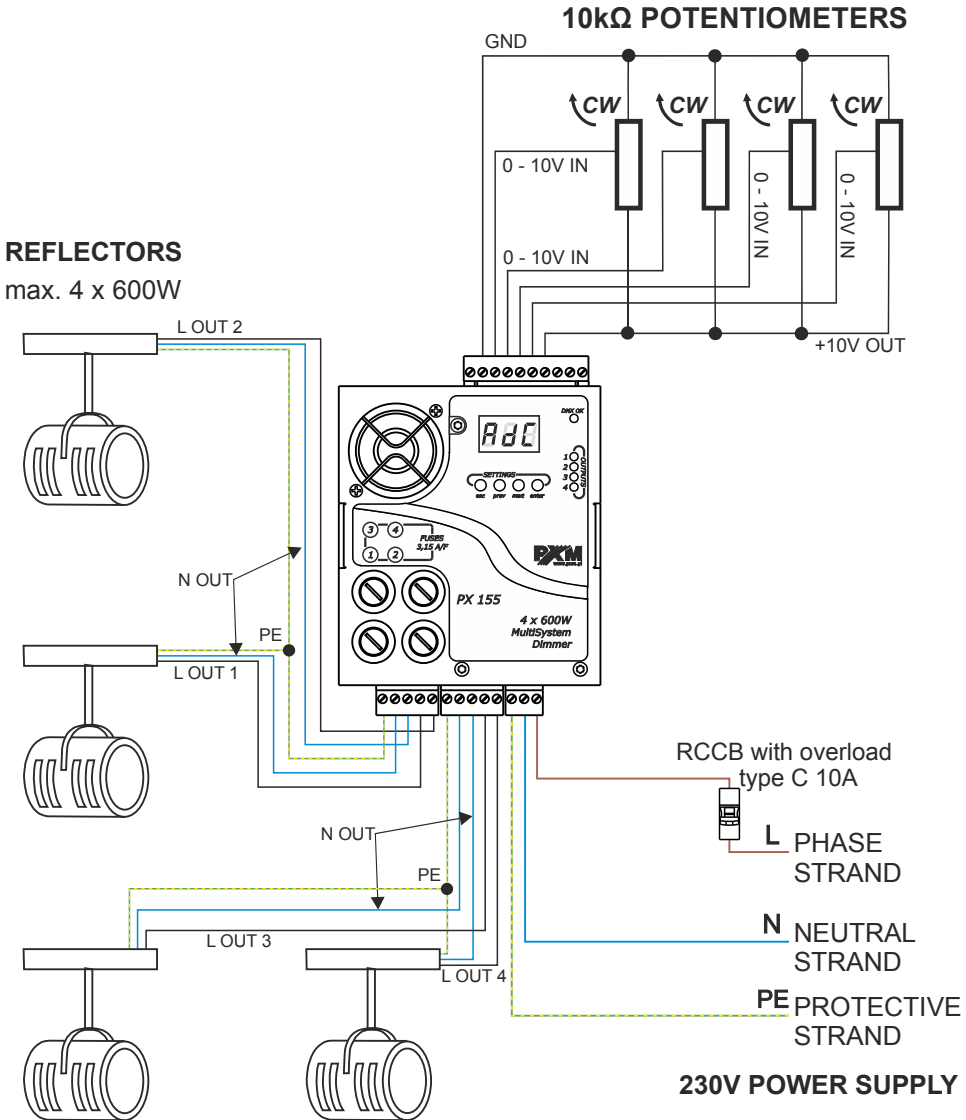

# 11.3 0 – 10V control

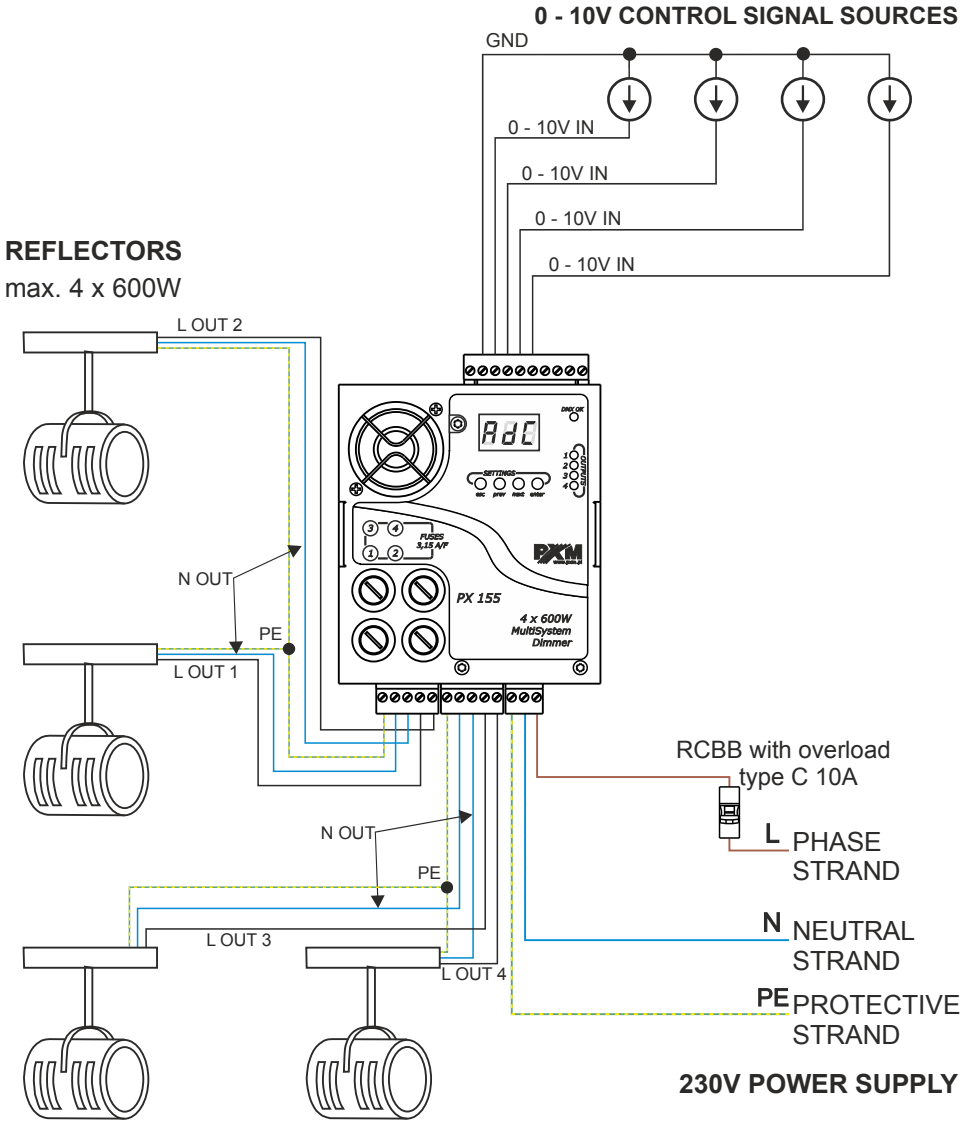

# 11.4 Monostable buttons control

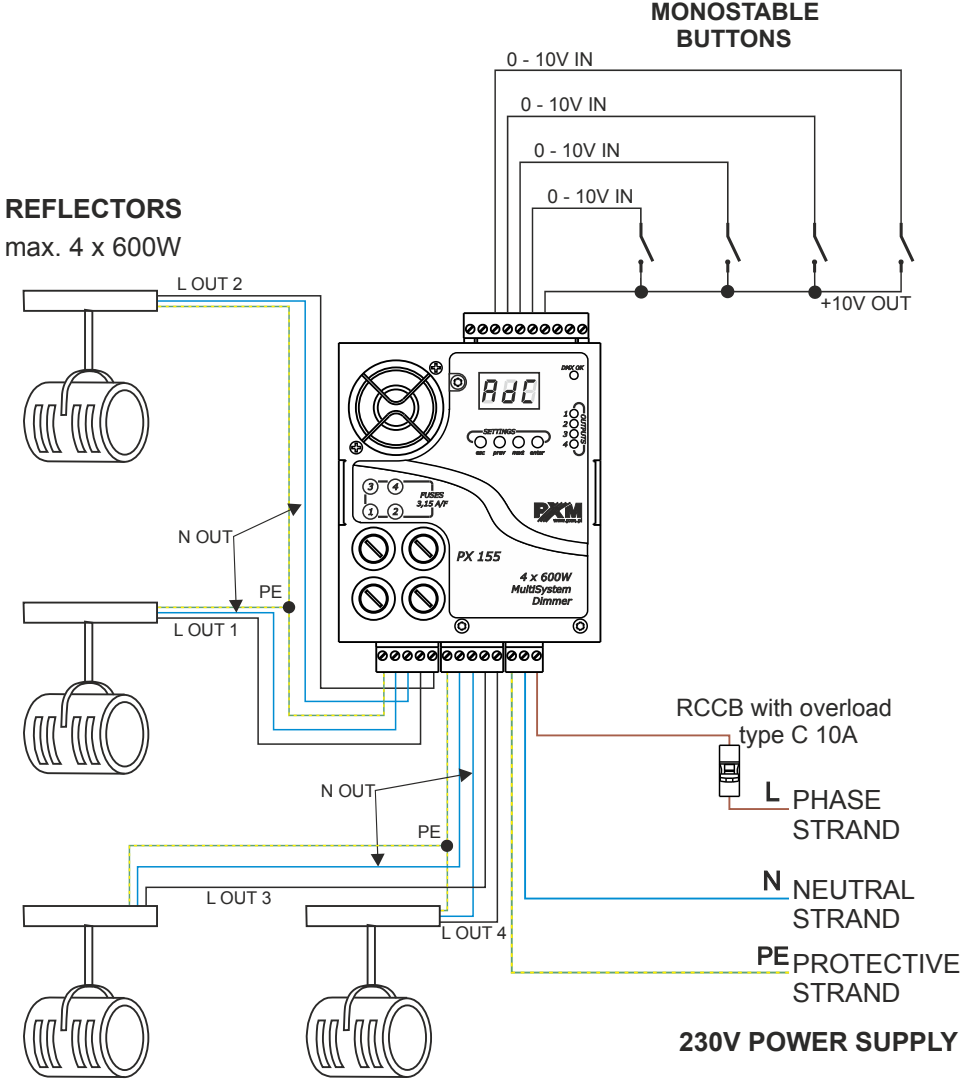

## 12 Dimensions

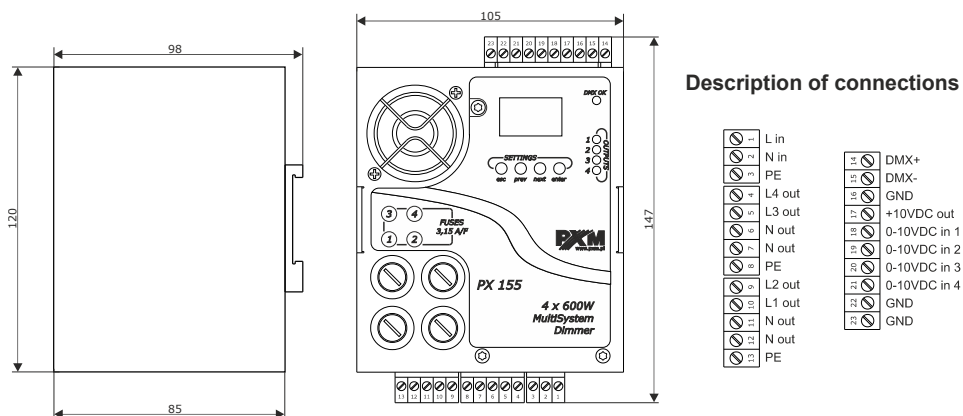

## 13 Notes

\* neon lamps control characteristic – each characteristic ( $nE1$ ,  $nE2$ ,  $nE3$ ) is dedicated to inductive load control as for neon lamp transformers. Differences between characteristics are only in lamp switching level, so the start brightness of the lamp. The suitable characteristic should be decided depending on user light installation.

## 14 Technical data

---

type	PX155
power supply	230V AC
max. current consumption	10A
control inputs	digital DMX-512 signal analog 0 – 10V monostable keys
current consumption input 0 – 10V	1mA
load capacity of the control output +10V out	10mA
thermal protection	60°C – automatic launch of electronically controlled fan 90°C – output power decrease by 10% 100°C – automatic dimmer shutdown
noise emitted by the dimmer at a distance of 15cm from the device	45dB (with 30 – 40% control)
weight	1.1kg
dimensions	width: 105mm height: 147mm depth: 98mm



## DECLARATION OF CONFORMITY

PXM Marek Żupnik spółka komandytowa  
Podłęże 654, 32-003 Podłęże

we declare that our product:

*Product name:* MultiSystem Dimmer 4 x 600W

*Product code:* PX155

meets the requirements of the following standards, as well as harmonised standards:

PN-EN IEC 63000:2019-01

EN IEC 63000:2018

PN-EN 62368-1:2015-03

EN 62368-1:2014

PN-EN 61000-4-2:2011

EN 61000-4-2:2009

PN-EN IEC 61000-6-1:2019-03

EN IEC 61000-6-1:2019

PN-EN 61000-6-3:2008

EN 61000-6-3:2007

and meets the essential requirements of the following directives:

**2011/65/UE DIRECTIVE OF THE EUROPEAN PARLIAMENT AND OF THE COUNCIL** of 8 June 2011 on the restriction of the use of certain hazardous substances in electrical and electronic equipment  
Text with EEA relevance.

**2014/30/UE DIRECTIVE OF THE EUROPEAN PARLIAMENT AND OF THE COUNCIL** of 26 February 2014 on the harmonisation of the laws of the Member States relating to electromagnetic compatibility (recast)  
Text with EEA relevance.

**2014/35/UE DIRECTIVE OF THE EUROPEAN PARLIAMENT AND OF THE COUNCIL** of 26 February 2014 on the harmonisation of the laws of the Member States relating to the making available on the market of electrical equipment designed for use within certain voltage limits

  
**Marek Żupnik** spółka komandytowa  
32-003 Podłęże, Podłęże 654  
NIP 677-002-54-53



mgr inż. Marek Żupnik.