

PX124

AC
Dimmer
12 x 5500 W

INSTRUCTION
MANUAL



CONTENTS

1. General description.....	1
2. Safety conditions.....	1
3. Front panel view.....	2
4. Output signal interruption diagnosis.....	2
5. Programmable parameters.....	3
5.1. Group parameters.....	3
5.2. Individual parameters.....	4
5.3. Measurement functions.....	4
5.4. Scenes and chasers programming.....	4
6. Access lock.....	4
6.1. Switching the access lock on.....	4
6.2. Switching the access lock off.....	5
7. Menu scheme.....	5
8. Dimmer installation and connection.....	6
8.1. Dimmer view with door open.....	6
8.2. Mounting operations.....	7
8.3. External dimensions and mounting holes disposition.....	8
9. DMX signal connection.....	9
10. Technical specification.....	9
11. Declaration of conformity.....	10

Manufacturer reserves the right to make modifications in order to improve device operation.

<i>PXM s.c.</i>	<i>tel.: (+48 12) 626 46 92</i>
<i>ul. Przemysłowa 12</i>	<i>fax: (+48 12) 626 46 94</i>
<i>30-701 Kraków</i>	<i>E-mail: info@pxm.pl</i>
<i>POLAND</i>	<i>Internet: www.pxm.pl</i>

1. GENERAL DESCRIPTION

PX095 is a professional AC class dimmer 12 x 5500 W powered with 3 phases, 2 phases or 1 phase. The dimmer controls 12 independent channels, 5.5 kW each. Advanced electronics allows to address easily each channel, to choose the control curve, to set output voltage limitation and preheat level and to determine dimmer answer for the interruption of the DMX control signal as well.

Built-in PLL, soft-start, soft-on and even-off systems allow for the reliable work even in the most difficult conditions. Direct zero cross-over with opto-insulated DMX input guarantee high noise resistance. Tricolour LEDs for monitoring each channel and DMX control signal.

The device comes in the casing for wall mounting.

2. SAFETY CONDITIONS

PX124 AC Dimmer is powered directly from standard 230 V grid, what can cause electric shock when safety rules are not observed. Therefore it is necessary to observe the following :

1. Installation, particularly power connection, should be performed by a person holding the appropriate qualifications, according to description in the instruction manual.
2. Dimmer can be connected to socket which has protecting instalation in working order only (3- or 5-wire grid with the separate protective strand).
3. All the conductors should be protected against mechanical and thermal damage.
4. In the event of damaging any conductor, it should be replaced with a conductor of the same technical data and attestations.
5. The external devices can be connected to the dimmer with 3-strand 4.5 mm² minimum cross-section area only.
6. Each receiver has to be powered with a separate cable.
7. After the installation is completed, check the neutralization efficacy of all powered devices.
8. All repairs demanding casing opening should be made with cut off power supply.
9. The device should be strictly protected against water and other liquids.
10. All sudden shocks, particularly dropping, should be avoided.
11. Device with damaged (cracked) casing should not be connected to the mains.
12. The device cannot be turned on in places with humidity exceeding 80%.
13. The device cannot be used in places with temperature lower than 2°C or higher than 40°C.
14. Clean with damp duster only - dimmer has to be cut off the power supply.

ATTENTION!!!

1. Improper connection of the protective wire (yellow-green strand) can cause electric shock.
2. Improper connection of the neutral wire (blue strand) automatically switches the dimmer off and activates an acoustic alarm.
3. The dimmer can control resistative and inductive circuits (loads) only. The dimmer cannot be used for controlling the electronic transformers, electronic ballasts for fluorescent lamps and other devices that have electronic circuits, unless the producer distinctly states so.

3. FRONT PANEL VIEW

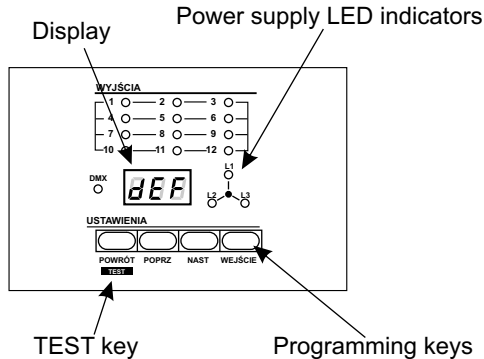

SETTINGS

There are four buttons for dimmer programming:

- WEJŚCIE - enters the programming mode or next menu level and confirms settings
- NAST - scrolls the MENU forward or increases values set
- POPRZ - scrolls the MENU backwards and decreases values set
- POWRÓT - allows to cancel programming (without saving)

DMX OK

Twinkle LED for DMX signal presence.

TEST

When the dimmer is not in the programming mode (the display shows DMX address), the TEST button forces all outputs to light up at 100%, lights all the LEDs and all the display segments. It also checks the output lines status (used bulbs).

DISPLAY

During normal operation shows the DMX address of the first channel. During programming mode shows currently programmed parameter.

L1, L2, L3

Power control LEDs. For the proper work of the dimmer at least L1 LED should be lit up.

4. OUTPUT SIGNAL INTERRUPTION DIAGNOSIS

Three-colours LEDs diagnose status and condition of outputs channels. Their brightness is proportional to light intensity at suitable channel and the LEDs colours (green, yellow, red) mean in order:

- green - channel is ok (working properly)
- yellow - channel is working with individual settings
- red - channel is working improperly or not working. Possibility of damage of cable or bulb.

The last function (red sign) is visible while button TEST is pressed and held. The LEDs that are assigned to damaged channels will turn RED and the others LEDs will light up green.

After the TEST button is released, the dimmer turns back to normal work and all the channels within the damage was diagnosed will be still enabled (applies to software 2.04 version or newer).

5. PROGRAMMABLE PARAMETERS

The dimmer allows to define the following operation parameters:

1. The group parameters - **ALL** menu

Chosen settings are same for all channels. In case of the DMX address, the displayed value is related to the first channel. For all the other channels subsequent address values are assigned.

2. Individual parameters - **Ind** menu

Each channel can be programmed individually. It applies also to the DMX address. The same address can be programmed for several channels.

Group parameters have higher priority than individual ones. It means that when the DMX address is programmed in the **ALL** mode, the previous settings for all twelve channels will be cancelled.

3. Measurement functions - **Fun** menu

This function allows to check the internal dimmer temperature and supply voltage values.

4. Scenes and chasers programming - **DEF** menu

This function enables to program:

- settings for all three scenes,
- twelve steps settings and the speed and fading of programmable chaser,
- speed and fading of the factory-defined chaser.

5.1. GROUP PARAMETERS

1. **AdF** - DMX address. It is chosen from the 1 - 501 range (when 501 address is chosen, channel no. 12 has the address 512).

2. **CUF** - control curve choice. There are 8 options to choose from:

Lin - linear,

SPC - switchable,

Inv - inverted,

LnU - logarithmic,

EXP - exponential,

NEI...**NEE** - for neon lamps control.

3. **REL** - limit. Limiting the output voltage in the range from 50 - 230 V.

4. **PFE** - preheat. Heating up the bulb filaments. Set in the range from 0 - 10 %.

5. **nsS** - lack of signal. It determines functioning of the dimmer according to parameters defined in case of DMX signal interruption. There are 9 options to choose from:

On - turning all outputs on at 100%,

OFF - turning all outputs off,

Hld - the last received value is held,

TL - slow output switching off (about 20 secs),

SET...**SEE** - programmable scenes,

CF - factory-defined chaser,

CFP - programmable chaser.

5.2. INDIVIDUAL PARAMETERS (Ind MENU)

1. **ADP** - DMX address. Chosen from the 1 - 512 range.
2. **CDP** - control curve choice. There are 8 options to choose from:
 - LIN** - linear,
 - SWP** - switchable,
 - INV** - inverted,
 - LOG** - logarithmic,
 - EXP** - exponential,
 - NE1...NE8** - for neon lamps control.
3. **REL** - limit. Limits the output voltage in the range from 50 - 230 V.

5.3. MEASUREMENT FUNCTIONS (Fun MENU)

1. **PEP** - internal dimmer temperature.
2. **U11**, **U21**, **U31** - power supply voltage.

5.4. SCENES AND CHASER PROGRAMMING (dEF MENU)

1. **SE1...SE3** - scenes programming
 - CH1 ... CH2** - the number of the edited channel
 - 001 ... 100** - channel value described in %.
2. **CFP** - programmable chaser
 - F01 ... F12** - numbers of the edited scenes
 - CH1 ... CH2** - numbers of the edited channel
 - 001 ... 100** - the value of the chosen channel described in %
 - SPD** - chaser speed in the range 1 - 32
 - FAD** - switching on / off the crossfade function.
3. **CFP** - factory-defined chaser
 - SPD** - chaser speed in the range 1 - 32
 - FAD** - switching on / off the crossfade function.

6. ACCESS LOCK

Because of a great number of possibilities when defining the dimmer functions, all introduced changes can be protected with a code (number in a range from 0 - 255). The **dEFE** position of the main menu will be also hidden.

6.1. SWITCHING THE ACCESS LOCK ON

1. In the basic position of the display (DMX address of the first channel) push and hold TEST button, push shortly NAST button and release TEST button - **PR5** will show.
2. Push WEJŚCIE button - **EN6** inscription will show.
3. Push WEJŚCIE button again - the last set code will show.
4. Set new code using POPRZ and NAST buttons (or leave the previous one) and confirm changes by pressing the WEJŚCIE button.

8. DIMMER INSTALLATION AND CONNECTION

8.1. DIMMER VIEW WITH DOOR OPEN

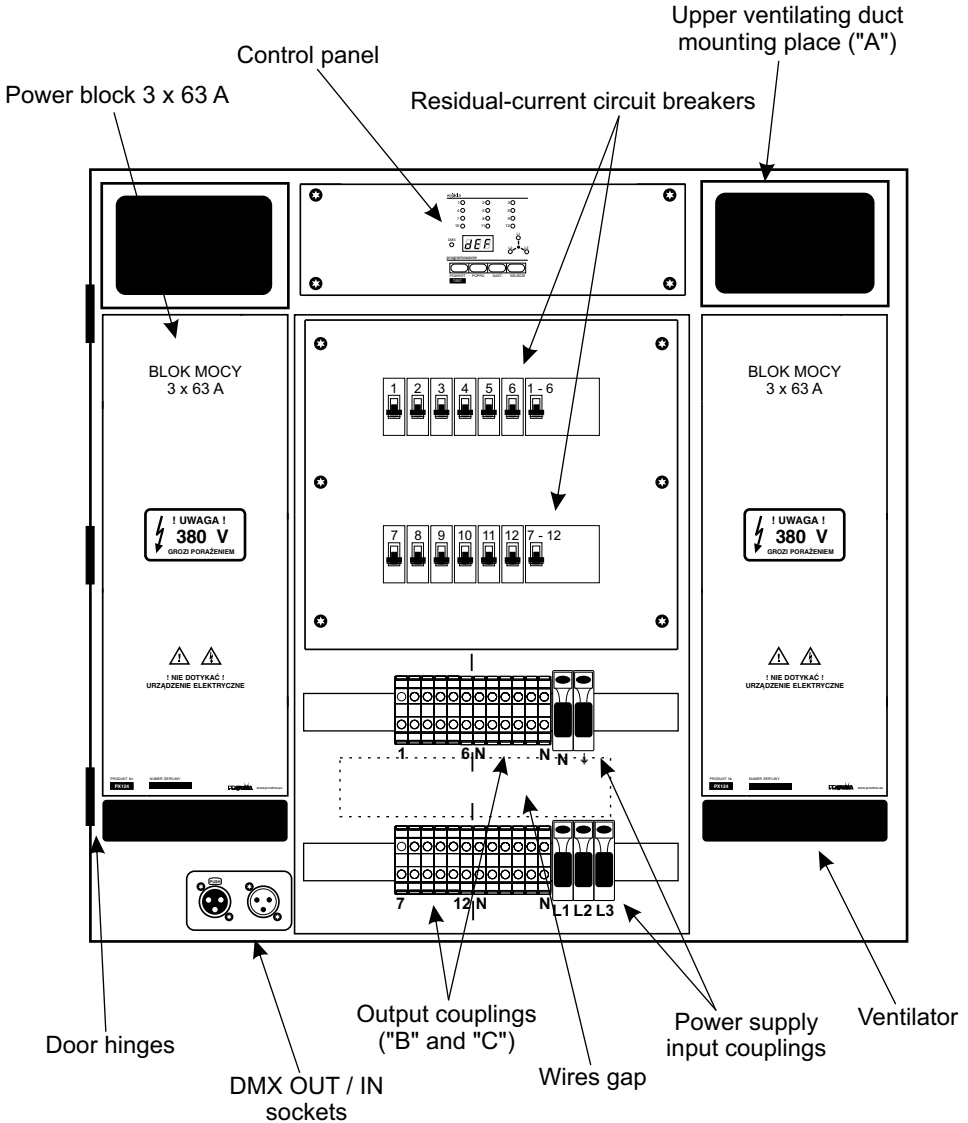

Current clamps colours:
 grey = phase 1
 grey = phase 2
 grey = phase 3
 blue = neutral
 yellow-green = protective

ATTENTION!!!

1. Improper connection of the protective wire (yellow-green strand) can cause electric shock.
2. Improper connection of the neutral wire (blue strand) automatically switches the dimmer off and activates an acoustic alarm.

8.2. MOUNTING OPERATIONS

All electric connections can be made by a person holding the appropriate qualifications only!!!

1. Mount the plugs in the wall, according to the dimensions given on page 8. The size and type of the wall plugs depend on wall quality. You must select such a type, that will assure a secure and durable dimmer mounting, taking into consideration its weight. It is strictly recommended not to use the plugs of a diameter smaller than 12 mm.
2. Unscrew the screws placed in the area marked as "A" on the figure on page 6.
3. Stick out both upper ventilating ducts.
4. Fasten the dimmer to the wall.
5. Insert the ventilating ducts.
6. Twist the duct-fastening screws - "A".
7. Connect the power cables to power supply sockets.

ATTENTION:

1. *You need to pay special attention to proper connection of the protective cable.*
2. *Depending on loads installed, select the power cables cross-section area according to engineering standards.*

8. Connect the receivers to output couplings.

ATTENTION:

The phase and neutral cable have to be connected to the same group of clamps (marked as "B" or "C" on the figure on page 6). You must not connect the neutral cable of one receiver to group "B" and the phase cable to group "C" and vice versa.

9. Turn all the automatic fuses and residual-current circuit breakers off.
10. Turn the external power supply switch on.
11. Switch on both residual-current circuit breakers. The control panel should light up.

ATTENTION:

If the control panel does not turn on and the acoustic alarm is activated, you have to instantly cut off power supply and check the correctness of the power cables connection.

12. Switch on the automatic fuse no. 1 and press the TEST button for channels 1 - 12. Check if the circuit no. 1 lights (as long, as the TEST button is pressed).
13. Check all the other circuits in the same way.
14. Connect the DMX cables.
15. Program the dimmer according to the description in the present instruction manual.

8.3. EXTERNAL DIMENSIONS AND MOUNTING HOLES DISPOSITION

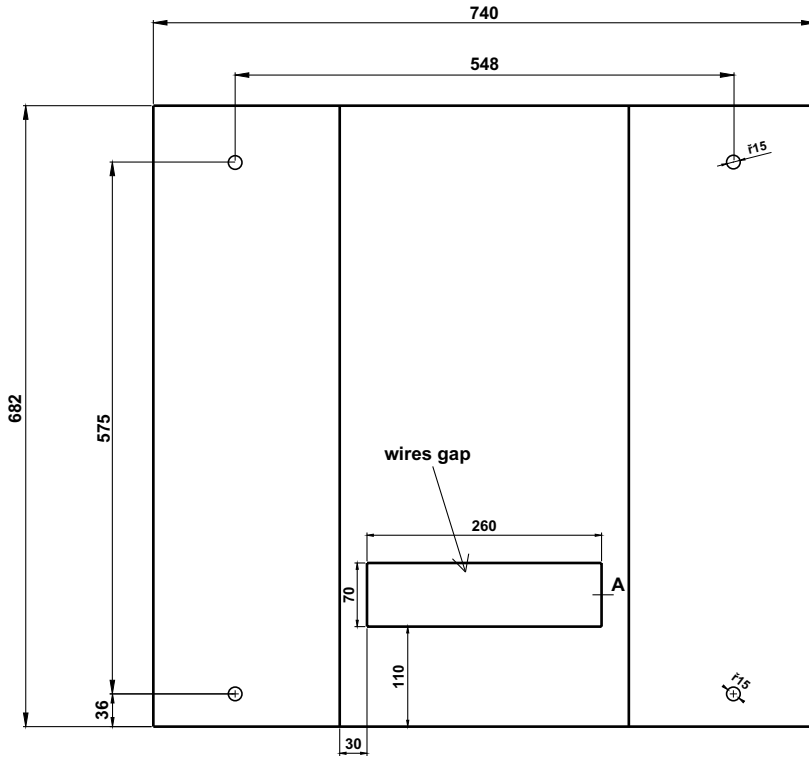

TOP VIEW

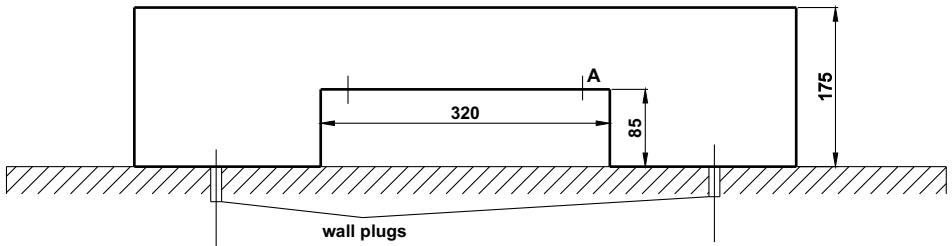

Minimal distance between devices: 20 mm.

9. DMX SIGNAL CONNECTION

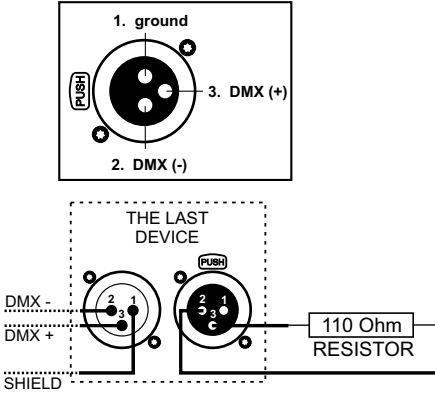

1. To connect devices use of the microphone cable is recommended (two strands in the shield).
2. The devices should be connected in series.
3. To split the DMX line it is necessary to use the DMX SPLITTER (PX094).
4. In case of the great number of devices or long distances use the DMX REPEATER (PX097). It is an amplifier of the DMX signal.
5. In the last device a terminator should be installed. It is a 110 Ohm resistor.

10. TECHNICAL SPECIFICATION

- DMX channels	1 - 512
- DMX line optical insulation	yes
- circuit break detection	yes
- supertension protection	yes
- fans	elektronically controlled
- outputs load capacity	12 x 5500 W continuous load (resistantive) 12 x 3900 VA continuous load (inductive)
- outputs protection	25 A automatic fuses
- residual-current protection	yes
- power supply	3 x 230 V / 40 - 70 Hz
- output sockets	clamping screws, minimal cable cross-section: 4,5mm ²
- input sockets	clamping screws, minimal cable cross-section: 10 mm ²
- current consumption	3 x 128 A (at full load)
- weight	50 kg
- dimensions:	
- width	740 mm
- heigth	682 mm
- depth	175 mm





ul. Przemysłowa 12
30-701 Kraków, Poland

tel: +48 12 626 46 92
fax: +48 12 626 46 94

e-mail: info@pxm.pl
http://www.pxm.pl

DECLARATION OF CONFORMITY
according to guide lines 73/23/EWG and 89/336/EWG

Name of producer: PXM s.c.

Address of producer: ul. Przemysłowa 12
30-701 Kraków

declares that the product:

Name of product: **AC Dimmer 12 x 5500 W**

Type: **PX124**

answers the following product specifications:

LVD: PN-EN 60065

EMC: PN-EN 55014

Additional informations:

1. All DMX512 inputs and outputs must be shielded and the shielding must be connected to pin 1 XLR plug.
2. A ground wire of the dimmer power cable must be connected to efficient ground installation.

PXM S.C.
Danuta i Marek Żupnik
30-701 Kraków, ul. Przemysłowa 12
NIP 677-002-54-53

Kraków, 01.06.2006

Marek Żupnik M.Sc.