

PX106 (128 channels)
PX105 (64 channels)
PX114 (32 channels)

DMX Demultiplexer

INSTRUCTION
MANUAL



CONTENTS

1. General description.....	1
2. Safety conditions.....	1
3. Rules of creating the DMX installation.....	2
4. DMX starting address setting.....	2
5. Front panel view.....	3
6. Programmable parameters.....	4
7. Demultiplexer programming.....	4
8. DMX signal connection.....	5
9. Analog signals connection.....	5
10. Technical specification.....	5
11. Declaration of conformity.....	6

Manufacturer reserves the right to make modifications in order to improve device operation.

<i>PXM s.c.</i>	<i>tel.: (+48 12) 626 46 92</i>
<i>ul. Przemysłowa 12</i>	<i>fax: (+48 12) 626 46 94</i>
<i>30-701 Kraków</i>	<i>E-mail: info@pxm.pl</i>
<i>POLAND</i>	<i>Internet: www.pxm.pl</i>

1. GENERAL DESCRIPTION

DMX Demultiplexer is a converter, that enables the co-operation of a DMX system with the devices controlled with the analog signal. The received DMX signal is decoded and sent to the outputs as the standard 0 / +10 V analog signals.

PX106 DMX Demultiplexer is a professional device that can receive the data from 128 DMX channels and convert them into the 0 / +10 V analog form. The device maintenance is very simple - after the signal cables are connected and the DMX starting address is set the receiver is ready to operate. The DMX starting address is set with the four buttons and the alphanumeric display.

The device is manufactured in a standard 19" 1U mechanics, adapted for stand mounting.

PX106 is also equipped with the DMX signal LED indicator and the control buttons, that allow to test the outputs.

Depending on the number of analog outputs, 3 versions of demultiplexer are manufactured:

PX106	-	128 outputs
PX105	-	64 outputs
PX114	-	32 outputs

2. SAFETY CONDITIONS

DMX Demultiplexer PX105 / PX106 / PX114 is powered directly from standard 230 V grid, what can cause electric shock when safety rules are not observed. Therefore it is necessary to observe the following:

1. The device installation can be performed by a person holding the appropriate qualifications only, according to the description in the instruction manual.
2. Demultiplexer can be connected to socket which has protecting instalation in working order (3 - wire grid) only.
3. All the conductors should be protected against mechanical and thermal damage.
4. In the event of damaging any conductor, it should be replaced with a conductor of the same technical data and attestations.
5. All repairs demanding casing opening should be made with cut off power supply.
6. Demultiplexer should be strictly protected against contact with water and other liquids.
7. All sudden shocks, particularly dropping, should be avoided.
8. Device with damaged (cracked) casing should not be connected to the mains.
9. The device cannot be turned on in places with humidity exceeding 90%.
10. The device cannot be used in places with temperature lower than 2°C or higher than 40°C.
11. Cleaning only with damp duster - demultiplexer has to be cut off the power supply.

3. RULES OF CREATING THE DMX INSTALLATION

The frequent cause of a seeming malfunction of the DMX devices is their improper connection in a DMX installation. The DMX protocol strictly defines the rules of creating a control installation - below is a scheme of a proper demultiplexer incorporation into a DMX installation.

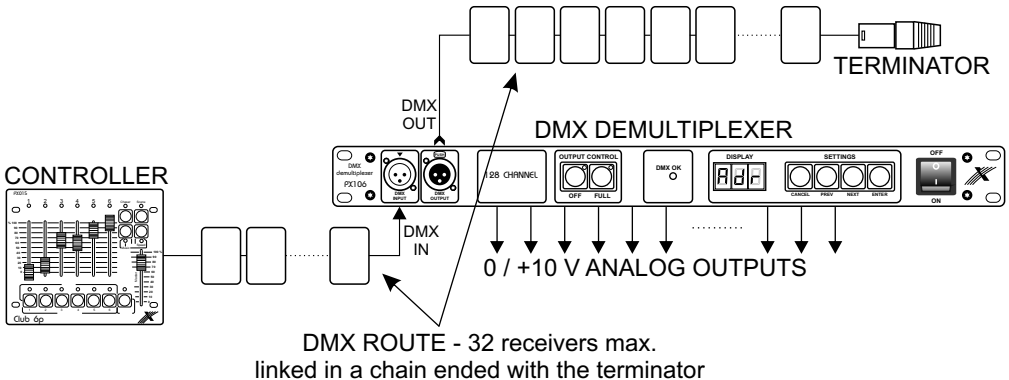

TERMINATOR = 90 - 120 Ohm resistor at the output of the last receiver in a route (connected to DMX+ and DMX- pins)

The demultiplexer incorporation into a DMX control route is realized with the DMX input and output sockets placed on the device's front panel (adequately described XLR-3 plug and socket). If the demultiplexer is the last device in a DMX chain, the terminator must be connected to its DMX output. If the DMX route contains more than 32 receivers or its physical length exceeds 500 meters you need to use the DMX signal amplifiers (DMX repeaters).

4. DMX STARTING ADDRESS SETTING

The demultiplexer codes 128 subsequent DMX channels, starting with the defined starting address. The address setting is made with the buttons, described in the further part of the present manual. As the DMX signal contains control data for 512 channels, when the starting address is set above 384, the decoded channels number is reduced with reference to available 128. When the starting address is being tried to be set as higher than 512 it will be corrected automatically.

5. FRONT PANEL VIEW

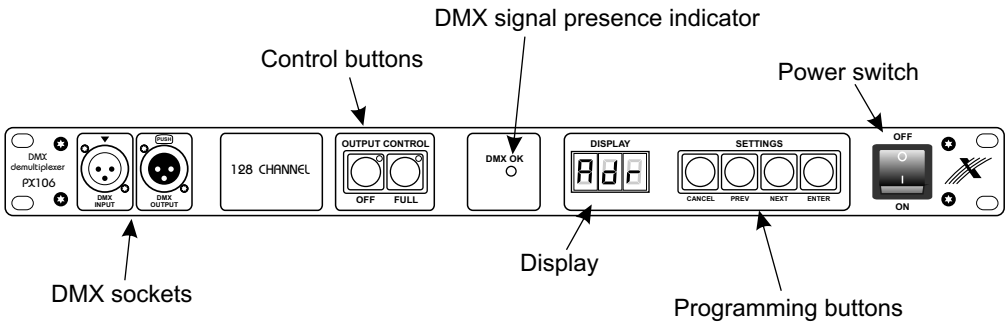

DMX SOCKETS

The described DMX route couplings (input plug and output socket). With these sockets the demultiplexer can be incorporated to the DMX installation. You must remember to connect the terminator on the output, if the demultiplexer is the last device in a DMX chain.

DISPLAY

During the standard operation mode displays the first channel's DMX address. During programming displays the currently programmed parameter.

PROGRAMMING BUTTONS

Four buttons for demultiplexer's parameters programming:

ENTER - enters the menu and confirms the defined values

NEXT - scrolls the menu forwards or increases the programmed values

PREV - scrolls the menu backwards or decreases the programmed values

CANCEL - returns to the previous menu and discards the changes made

CONTROL BUTTONS

OFF and FULL control buttons are for checking the receivers connected to the demultiplexer. Regardless of the input DMX transmission status these buttons force adequately turning all the outputs off (OFF button) or control with full power (FULL button). Use of the control buttons facilitates for instance locating the used bulbs in the executory devices.

DMX SIGNAL PRESENCE INDICATOR

The indicator twinkles, when the transmission is correct. When the indicator is off, the DMX signal is absent or its parameters are incorrect.

6. PROGRAMMABLE PARAMETERS

1. **AdP** - DMX address. Set in a range from 1 to 512.
2. **n05** - no signal. Defines the demultiplexer's reaction to DMX signal absence or interruption.

You may choose from 6 possibilities:

- 0n0** - turning all the outputs on at 100%,
- 0FF** - turning all the outputs off,
- HLD** - holding up recently controlled values,
- 2-L** - slow dimming of all the outputs (20 seconds approximately),
- H5F** - turning all the outputs on at 50%,
- 30d** - turning all the outputs on at 30%.

7. DEMULTIPLEXER PROGRAMMING

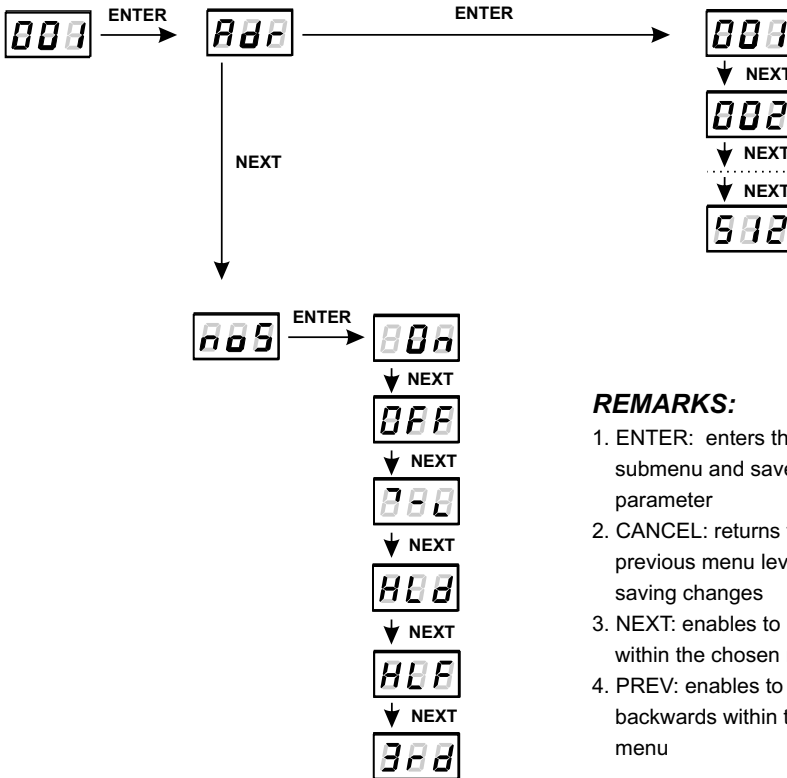

REMARKS:

1. ENTER: enters the next submenu and saves chosen parameter
2. CANCEL: returns to the previous menu level without saving changes
3. NEXT: enables to move forward within the chosen menu
4. PREV: enables to move backwards within the chosen menu

8. DMX SIGNAL CONNECTION

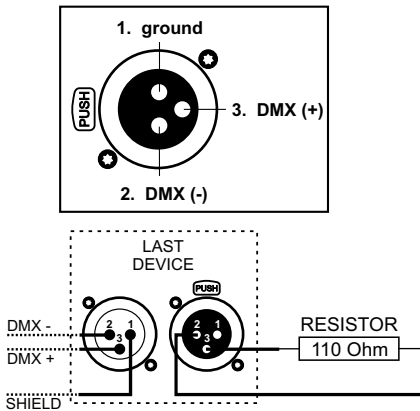

1. To connect the devices application of the microphone cable is strictly recommended (two strands in a shield).
2. The devices have to be connected in series.
3. To split the DMX line it is necessary to use the DMX SPLITTER (PX094).
4. In case of the great number of devices or long distances use the DMX REPEATER (PX097). It is an amplifier of the DMX signal.
5. In the last device a terminator must be installed. It is a 110 Ohm resistor.

9. ANALOG SIGNALS CONNECTION

128 0 / +10 V analog outputs are driven out to 4 D-SUB37 sockets, placed on the rear panel. There are 32 subsequent outputs and 5 ground pins on each socket. The outputs are brought out to 1 - 32 pins, the ground to the pins nos. 33 - 37. Below is the illustration of pins disposition in the D-SUB37 socket (installed in the demultiplexer) and the D-SUB37 plug as well.

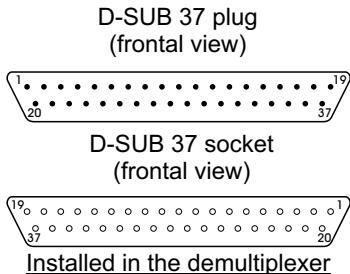

ATTENTION:

Pins 1-32: analog outputs

Pins 33-37: ground

When creating the signal cables it is recommended to use all the ground pins and creating the grounds connection with the cables of a large cross-section area.

10. TECHNICAL SPECIFICATION (PX106 version)

- DMX input	decoding 128 subsequent DMX channels, starting with the defined starting address
- analog input	128 0 / +10 V outputs, 20 mA / output max.
- DMX control sockets	XLR-3 plug and socket
- analog outputs	4 D-SUB 37 sockets
- power supply	230 V / 50 Hz, fuse on the rear panel
- weight	3 kg
- dimensions:	
- width	483 mm (19")
- height	44 mm (1U)
- depth	230 mm





ul. Przemysłowa 12
30-701 Kraków, Poland

tel: +48 12 626 46 92
fax: +48 12 626 46 94

e-mail: info@pxm.pl
<http://www.pxm.pl>

DECLARATION OF CONFORMITY

according to guide lines 73/23/EWG and 89/336/EWG

Name of producer: PXM s.c.

Address of producer: ul. Przemysłowa 12
30-701 Kraków

declares that the product:

Name of product: **DMX Demultiplexer**

Type: **PX105 / PX106 / PX114**

answers the following product specifications:

LVD: **PN-EN 60065**

EMC: **PN-EN 55103-1**
PN-EN 55103-2

Additional informations:

1. All DMX512 inputs and outputs must be shielded and the shielding must be connected to pin 1 XLR plug.
2. A ground wire of the demultiplexer power cable must be connected to efficient ground installation.

PXM s.c.
Danuta i Marek Żupnik
30-701 Kraków, ul. Przemysłowa 12
NIP 677-002-54-53

Kraków, 01.06.2006

Marek Żupnik M.Sc.